

# **ASHLAND INDUSTRIES**

## Parts Manual

9-16

# ***140TS2-001***

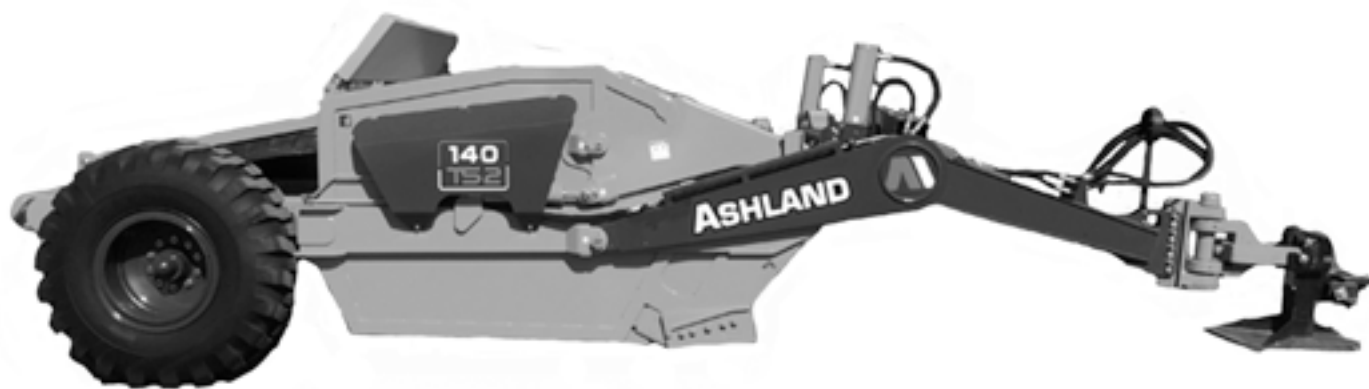

1115 Rail Drive  
P.O. Box 717  
Ashland, WI U.S.A.  
Toll Free: (877) 634-4622  
Business: (715) 682-4622  
Fax: (715) 682-9717

***Ashland Industries***

*Crafting Quality since 1953!*

[www.ashlandind.com](http://www.ashlandind.com)  
[www.scraperdrawbar.com](http://www.scraperdrawbar.com)

# Table of Contents

## Categorized Listing

<b>ASHLAND SCRAPERS</b>	<b>1</b>
Introduction	1
Operation and Maintenance	2
Safety Guidelines	5
Assembly - 140TS2-001	6
Swivel Hitch (#A125223)	7
Apron - 703011	9
Bowl & Frame -140	10
Front Section - 704013	11
Push-Off - 702014-702016-702015-140	12
Rear Wheel (140)	13
Apron Cylinder - A125050	14
Lift Cylinder - A123326	15
Trunion Blocks	16
Push-Off Cylinder- 400045	17
Hydraulic Schematic	18
Hydraulic Accumulator	19
Hydraulic Manifold - A125174	20
Hydraulic Valve Ports	21
Hydraulic Valve Seals	22
Hydraulic Plumbing Clamps	23
Service: Grease Locations TS	24
Tire Inflation	26
Maintenance Check List	27
Service: Tire Service	28
Troubleshooting	29
Warrantee Statement	30

---

# Table of Contents

## Alphabetized Listing

<b>A</b>	
Apron - 703011	9
Apron Cylinder - A125050	14
ASHLAND SCRAPERS	1-30
Assembly - 140TS2-001	6
<b>B</b>	
Bowl & Frame -140	10
<b>F</b>	
Front Section - 704013	11
<b>H</b>	
Hydraulic Accumulator	19
Hydraulic Manifold - A125174	20
Hydraulic Plumbing Clamps	23
Hydraulic Schematic	18
Hydraulic Valve Ports	21
Hydraulic Valve Seals	22
<b>I</b>	
Introduction	1
<b>L</b>	
Lift Cylinder - A123326	15
<b>M</b>	
Maintenance Check List	27
<b>O</b>	
Operation and Maintenance	2
<b>P</b>	
Push-Off - 702014-702016-702015-140	12
Push-Off Cylinder- 400045	17
<b>R</b>	
Rear Wheel (140)	13
<b>S</b>	
Safety Guidelines	5
Service: Grease Locations TS	24
Service: Tire Service	28
Swivel Hitch (#A125223)	7
<b>T</b>	
Tire Inflation	26
Troubleshooting	29
Trunion Blocks	16
<b>W</b>	
Warranty Statement	30



## ASHLAND SCRAPERS

# Introduction

Thank you for choosing an Ashland scraper for your earthmoving needs. Years of research, testing and successful application have been spent to ensure quality and maximum performance for our customers.

### QUALITY POLICY

**It is our mission to exceed our customers' expectations in quality, delivery, and cost through continuous improvement and customer interaction.**

Please read and understand this manual before attempting to attach or operate this scraper. This manual should always remain with the machine. Be sure and fill out and send in the owners registration form at the beginning of this manual, or you may fill out the form on-line by going to [ashlandind.com](http://ashlandind.com) and click on "Register your Machine" in the parts section drop-down. If you have questions, please feel free to call or email us. You can visit us on-line at [www.ashlandind.com](http://www.ashlandind.com).

Ashland Industries hours of operation are 8:00 a.m. to 5:00 p.m. CST. We can be reached toll free at: 877-634-4622.

### SCRAPER ID NUMBER

The serial number plate for the scraper is located on the right rear area of the scraper. The letter and numbers stamped identify the serial number, model number and capacity of the scraper. Please record this serial number for use in ordering parts, warranty issues and to track your equipment if it is ever stolen.

References to serial number breaks on parts are located in the manual with a reference sequence of XXXXX-XXXXX. The beginning number records the serial number start of the use of that part. The ending number is the final serial number use of the part within this machine.



### IMPORTANT

Parts must be ordered through your local authorized ASHLAND dealer. Be sure to state MODEL and SERIAL NUMBER of your machine. Ashland Industries weldable replacement parts are also available to rebuild, modify or update your scraper to current factory specifications.

**ASHLAND SCRAPERS****Operation and Maintenance**

Your Ashland scraper is a durable piece of equipment and with proper care will yield many years of trouble free operation. However, the life of your scraper can be severely shortened by poor maintenance. You must follow consistent maintenance practices and use good quality grease and hydraulic oil (compatible with the power unit's hydraulic system) to insure the longer, most productive use from your scraper.

Your scraper should be greased at all points where grease fittings are provided. **REMOVE TRANSPORT LOCKS** prior to operation. Next, extend and retract all cylinders several times to force out any air from the hydraulic cylinders and lines. Check the oil levels in the tractor hydraulic system and add to maintain the proper level. Care should be used when adding oil or when disconnecting any oil line to keep all dirt out of the oil as dirt is a major factor in the failure of hydraulic components.

When your scraper is placed into operation, the operator will have to "feel out" the amount of depth of cut to obtain maximum loading efficiency. This is usually accomplished by taking a lesser and more uniform cut; however, some soil conditions such as loose sand may require a "pumping action" obtained by taking successive deep cuts and lifting out of cut as the tractor begins to lose power or traction.

- After 8 hours of operation, all bolts should be checked and tightened if necessary and all grease fittings lubricated. Check tire pressures daily. Also, check pins and cutting edges for signs of wear.
- After 50 hours work, all bolts should be rechecked and tightened if necessary. Check wheel bearings and adjust if necessary.
- Check wheel lug nut torque.
  - After first 2 hours of operation.
  - Recheck daily for the next 2 weeks.
  - Tighten wheel lug nuts in a star pattern.
  - Torque wheel lug nut (see Torque Specifications).
- After 300 hours work, clean and repack wheel bearings and replace, if necessary, cutting edges, worn pins, etc.



**Failure to replace worn cutting edges may result in unnecessary wear to the earthmover sides and floor.**

**ASHLAND SCRAPERS****Operation and Maintenance**

Before starting a job, make sure Diggers Hot Line has been contacted and all underground utilities have been properly located (electric, phone and pipelines). Have a clear understanding of all local, OSHA and MSHA rules that apply to the job. Beware of your environment and keep others a safe distance from the machine while familiarizing yourself with the machine's controls. The scraper requires a power source with **TWO** 4-way (double acting) hydraulic control valves.

**Scraper damage can occur if:**

1. The scraper is running over the haul road with the bowl fully raised. On scrapers that have factory installed nitrogen over hydraulic accumulators, the lift cylinders should be lowered 3 to 4 inches to allow the cushioned ride to work properly.
2. The heaped payload repeatedly exceeds the design ISO 6485 Earth-moving machinery-Tractor-scraper volumetric rating.
3. The fully loaded scraper exceeds the 10 mph on smooth haul roads and dramatically less on uneven haul roads.
4. The scraper is being top-loaded without the bowl being fully lowered to the ground prior to placing the material into the bowl.
5. The scraper is being used to level haul roads with the apron closed, not allowing material to enter the bowl.
6. The scraper is being used to load rock.
7. The scraper is being aggressively push loaded with a dozer.
8. A power unit that is above the horsepower rating is pulling the scraper.

These types of damage are not covered by warranty. Warranty only covers defects in material or workmanship and not abuse because of improper use.

**Know the job:**

1. Know the weight of the material to be moved.
2. Lay the job out to take advantage of grades when loading, if possible.
3. Keep hauls as short as possible.
4. Keep haul roads smooth.
5. If more than one unit is on the job, make sure the haul roads are one way and that the operators understand the direction.
6. Brief the operators as to what the job consists of so there is not misunderstanding.
7. Know the moisture content in the material to be moved.
8. Will water be needed for proper compaction?
9. Will drainage be a problem?
10. How many units will be needed to efficiently complete the job?

**Transport the scraper safely:**

1. Always empty scraper.
2. Clean all material from exterior of scraper.
3. Make sure all road rules are followed.
4. Use proper lighting and flagging.
5. Lower scraper bowls to provide just enough clearance over obstacles.
6. Transport at a safe speed to avoid roll over.
7. Reduce speed on curves and when going downhill.

**ASHLAND SCRAPERS****Operation and Maintenance****Apron Opening Guidelines:**

You will need to determine the ideal opening for your soil condition. It is important to have the apron opened prior to loading. To receive the highest production possible, it is important to know the general characteristics of the material that you will be loading. In heavier soils like clay or gumbo, the soil will slab up and remain together after being cut by the blades. In lighter soils, like sand or dry loose top soil, the material will pile up or push after being cut by the blade. Use the suggestions listed below:

**Topsoil with heavy vegetation (12" to 24" opening):**

When cutting undisturbed soils, you will need to open the apron high enough to allow debris to easily enter the scraper bowl. If the apron is opened too high, the rolling up sod will fall out past the apron and hinder the incoming material. If the apron is not adjusted quick enough, the material will bunch or push ahead of the machine. If this happens, you should close the apron and pull out the cut quickly. If you wait too long, you may develop too large a pile to clear the scraper while rising out of the cut. This can cause the power unit to lose traction and possibly cause you to get stuck.

**Clay or loamy material: (6" to 12" opening):**

To cut clay or loam soils, lower the apron to approximately 6" to 12" between the blades and the bottom of the apron. When you first lower the bowl, you'll see the material being cut by the blades and entering the bowl. As you continue to move forward, small clumps will fall past the apron and develop a small pile ahead of the apron. By limiting this apron opening, the small pile will "blade off" any loose material ahead of the machine. Adjustments should be made if large objects such as rocks or deep gouges are within the cut.

**Sand or loose topsoil (15" to 30" topsoil):**

Loading sand or loose top soil is the most difficult type of soil to load. In combination with the larger apron opening, you'll want to operate at a faster ground speed. By traveling faster and lowering the blade deeper than normal, it forces the material into the scraper bowl.

We encourage you to experiment with different apron openings to determine the best condition for your jobsite.



The Apron is designed to capture material inside of the scraper bowl and should not be used as a large blade. Obstructions like large rocks or dense piles may cause the apron to bend inward after prolonged exposure to these conditions.



## Safety Guidelines



**Safety Signal Words:** Please note the use of signal words such as DANGER, WARNING, and CAUTION paired with the safety messages on your scraper. The appropriate signal word for each safety message has been selected using the following guidelines:

- **Danger:** Indicates an imminently hazardous situation that, if not avoided, will result in death or serious injury. This signal word is limited to the most extreme situations—typically for machine components which, for functional purposes, cannot be guarded.
- **Warning:** Indicates a potentially hazardous situation that, if not avoided, could result in death or serious injury. For example, hazards that are exposed when guards are removed. This signal word may also be used to alert against unsafe practices.
- **Caution:** Indicates a potentially hazardous situation that, if not avoided, may result in minor or moderate injury. This signal word may also be used to alert against unsafe practices.

Operator safety is a main concern in designing and developing equipment. Designers and manufacturers include as many safety features as possible. However, every year many accidents occur which could have been avoided by extra thought and a more careful approach to handling equipment. The operator can avoid many accidents by observing the precautions in this section. To avoid personal injury, study the following precautions and insist those working with, or for you, follow them.

Replace any CAUTION, WARNING, DANGER or instruction safety decal that is not readable or missing. Locations of decals are indicated in this booklet.

Do not attempt to operate this equipment under the influence of drugs or alcohol.

Review the safety instructions in the operator's manual with all users annually.

**Operators should be responsible adults who are familiar with machinery and trained in the equipment's operations. Do not allow persons to operate or assemble this unit until they have read this manual and the owner's manual and have developed a thorough understanding of the safety precautions and scraper operation.**

**Assembly - 140TS2-001**

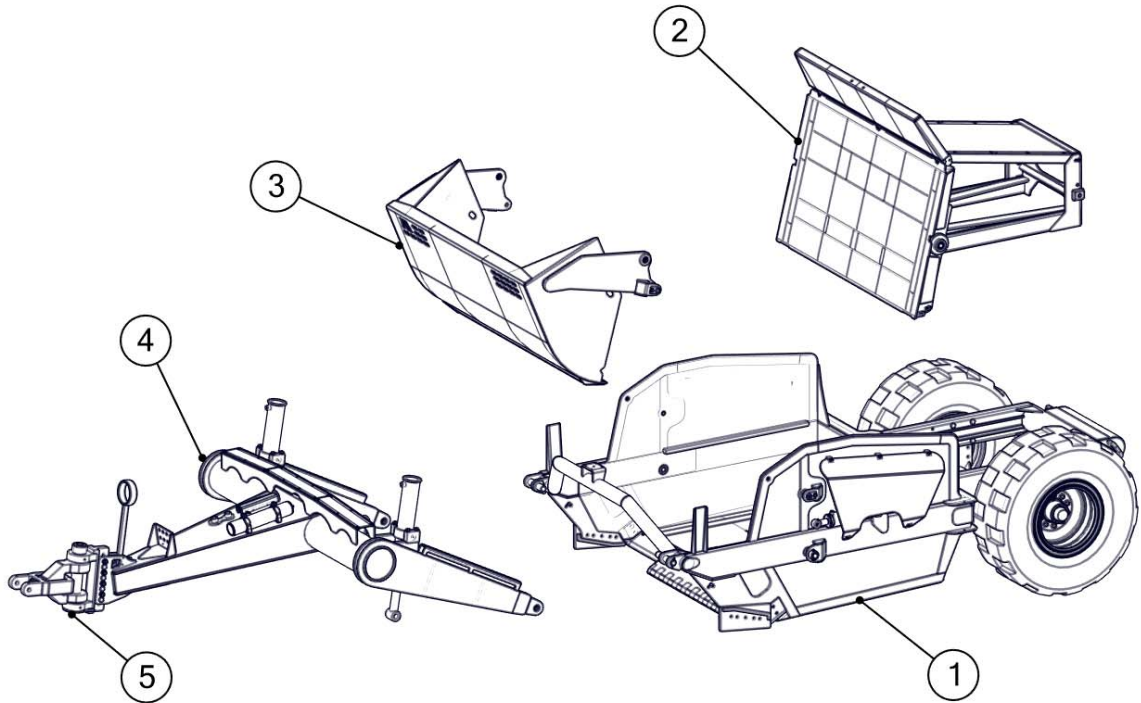

ITEM	PART	DESCRIPTION
	I-140TS2-001	140TS2 MAIN SCRAPER ASSEMBLY
1	701021	Bowl and Frame Assembly
2	702016	Pushoff Assembly
3	703011	Apron Assembly
4	704013	Front Section Assembly
5	A125223	Hitch: MDU Cast

## Swivel Hitch (#A125223)

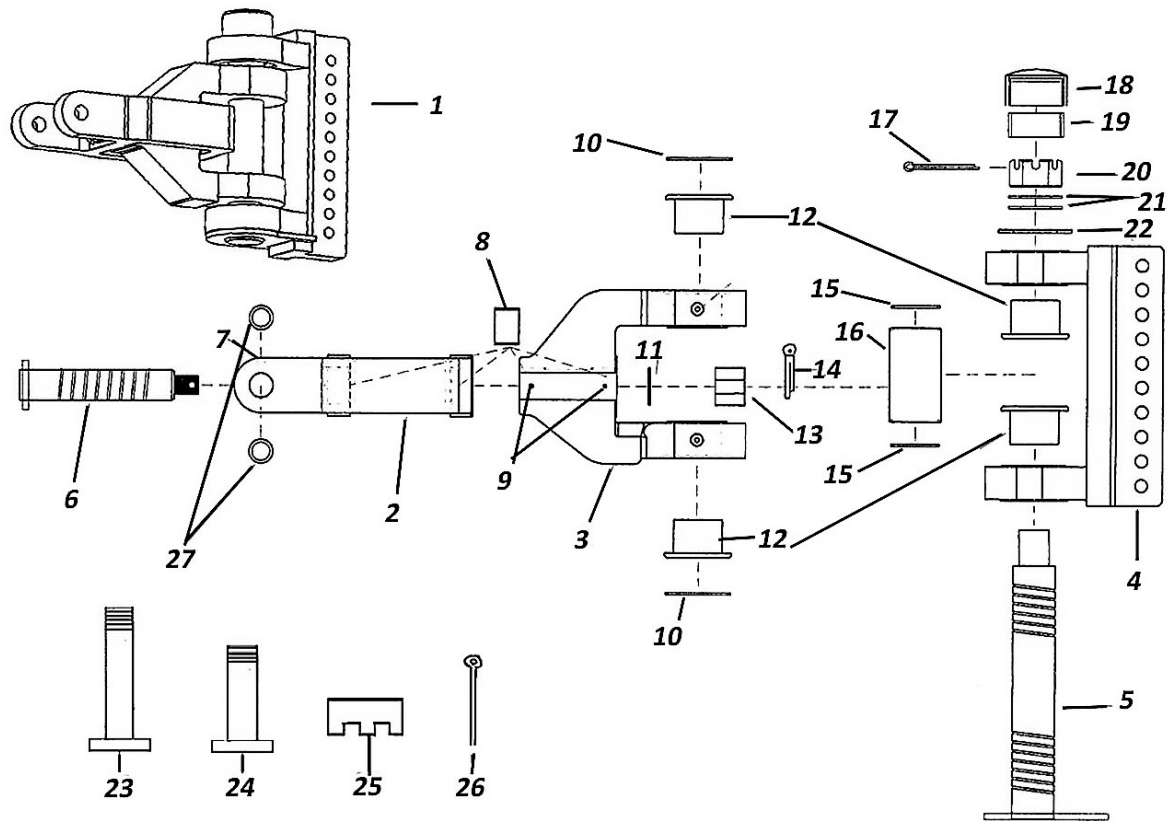

ITEM	PART	DESCRIPTION
1	A125223	Hitch: MDU cast
2	A125223-01	Yoke: A-Frame
3	A125223-02	Swivel
4	A125223-03	Bracket: 10 Hole
5	A125223-04	Pin: Main Vertical
6	A125223-06	Pin: Horizontal
7	14505	Grease Fittings
8	A125056-27	Bushing
9	AFH-00028	Grease Fitting 90 deg.
10	A125223-08	Seal: O-Ring
11	A125223-11	Washer - 1 1/2" for Horz. Pin
12	A125223-07	Bushing
13	A125223-12	Nut: Slotted 1 1/2" NC
14	AFP-00011	Cotter Pin
15	A125223-09	Seal: O-Ring
16	A125223--05	Spacer: 6"
17	AFP-00012	Cotter Pin
18	A125223-17	Cap: For Vertical Pin
19	A125223-16	Sleeve: 2" Rubber
20	A125223-15	Nut: Slotted 2 1/2" NC
21	A125223-14	Washer: 2 1/2"

**ASHLAND SCRAPERS****Swivel Hitch (#A125223)**

ITEM	PART	DESCRIPTION
22	A125223-13	Spacer
23	A123299-08	4-Ear Drawbar to Hitch Pin
24	A123299-07	2-Ear Drawbar to Hitch Pin
25	AFN-00014	1 1/2" Castle Nut
26	AFP-00001	Cotter Pin: 1/4" X 3"
27	A125056-24	Bushing

**Apron - 703011**

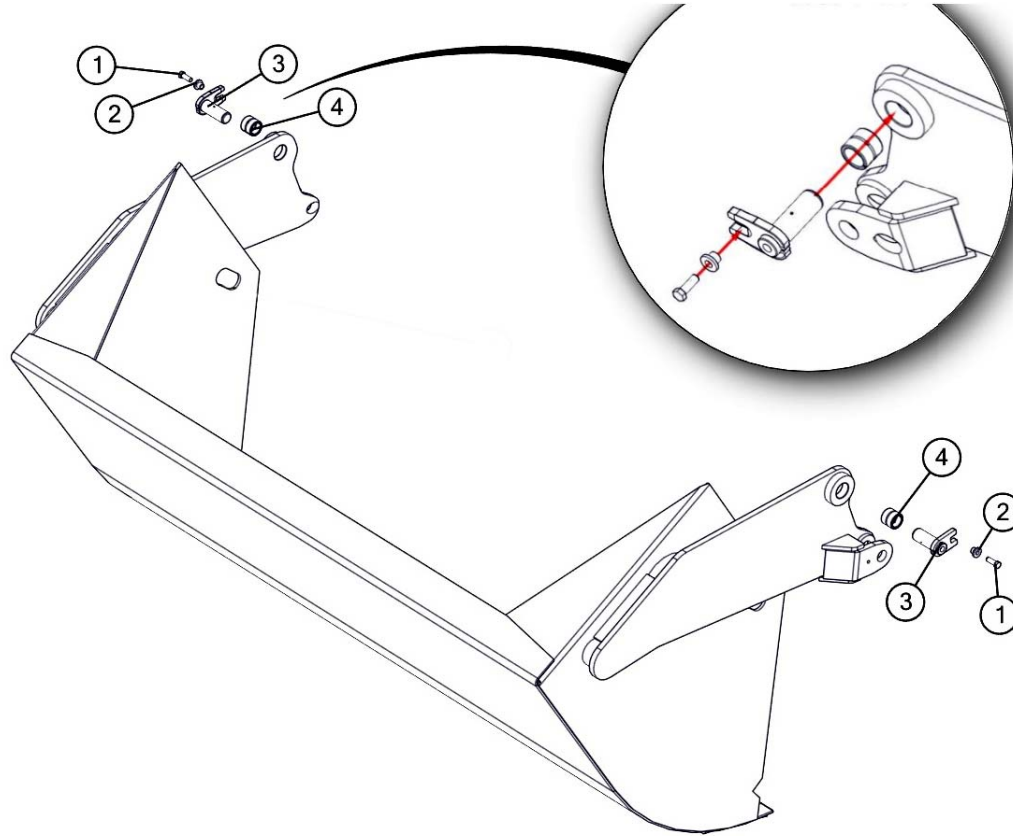

ITEM	PART	DESCRIPTION
1	A123351	Bushing: Pin Keeper 9 1/6" X 3/4" X 3/4"L
2	600993	Pin: Apron Cylinder Rod End
3	A123343	Bushing: 1 1/2" ID X 2" OD X 1 3/4"
4	AFB-00015	Bolt: 1/2" X 1 1/2" Hex Cap

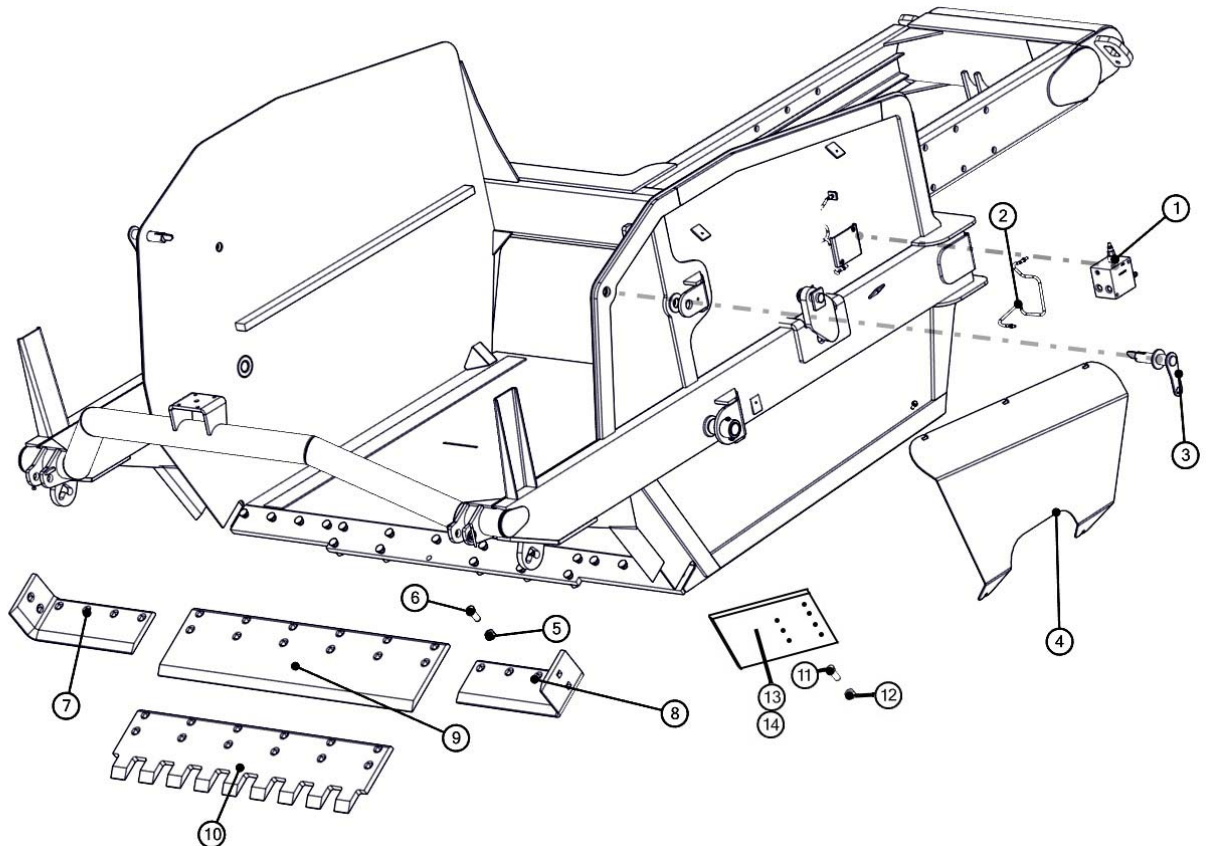
**ASHLAND SCRAPERS**
**Bowl & Frame -140**

ITEM	PART	DESCRIPTION
1	A125174	Valve: Manifold Block
2	A125022	Grease Line: 18" Ass'y
3	500494	Lock: Safety Pin
4	502743 (502744)	Guard: Apron Cylinder, LH (RH), 140
5	AFN-00019	Nut: 7/8" Hex
6	PB9P-NC-088-0275	Bolt: Plow 7/8" X 2 3/4" Gr 8
7	A123332R	Blade: Right 7/8 X 8 X 21 1/4" 90 deg.
8	A123332L	Blade: left 7/i X 8 X 21 1/4" 90 deg.
9	A123331	Blade: Center 1 X 13 X 54" Straight
10	A123331-SER	Blade: Center 1 X 13 X 54" Serrated (Optional)
11	PB9P-NC-088-0225	Bolt: Plow 7/8 X 2 1/4" Gr 8
12	AFN-00026	Nut: 7/8" Hex
13	A123338L	Blade: Left Bank Shaver (Optional)
14	A123338R	Blade: Right Bank Shaver (Optional)

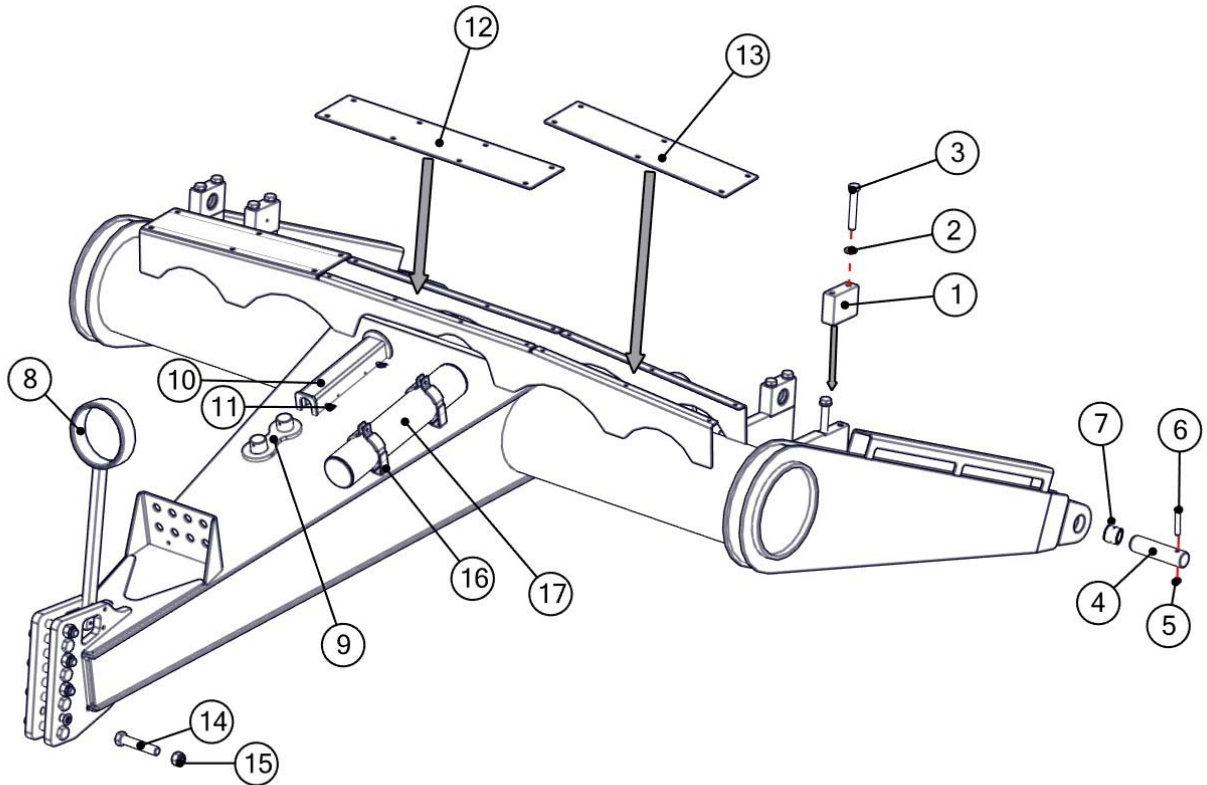
**ASHLAND SCRAPERS**
**Front Section - 704013**

ITEM	PART	DESCRIPTION
1	502143	Block: Trunion Mount
2	AFB-00039	Bolt: 3/4" X 5 1/2" Gr. 8
3	AFW-00024	Washer: 3/4" Flat
4	A10152A	Pin: Front Section to Frame
5	AFB-00054	Bolt: 1/2" X 3 1/2" Gr Hex Cap
6	AFN-00011	Nut: 1/2" Gr 8 Hex
7	A14039	Bushing: 2" ID X 2 3/8" OD X 2"L
8	600119	Hose Holder
9	A123320-20	Transport Lock
10	600100	Lock: Apron
11	A125261	Pin: P.B. Quick Rel.
12	502963	Guard: Front Section, Center
13	502962	Guard: Front section, Side
14	AFB-00021	Bolt: 1" X 5 1/2" Gr 8 Hex Cap
15	AFN-00037	Nut: 1" Top Lock
16	A125009	Clamp: Accumulator Bracket
17	A125051	Accumulator

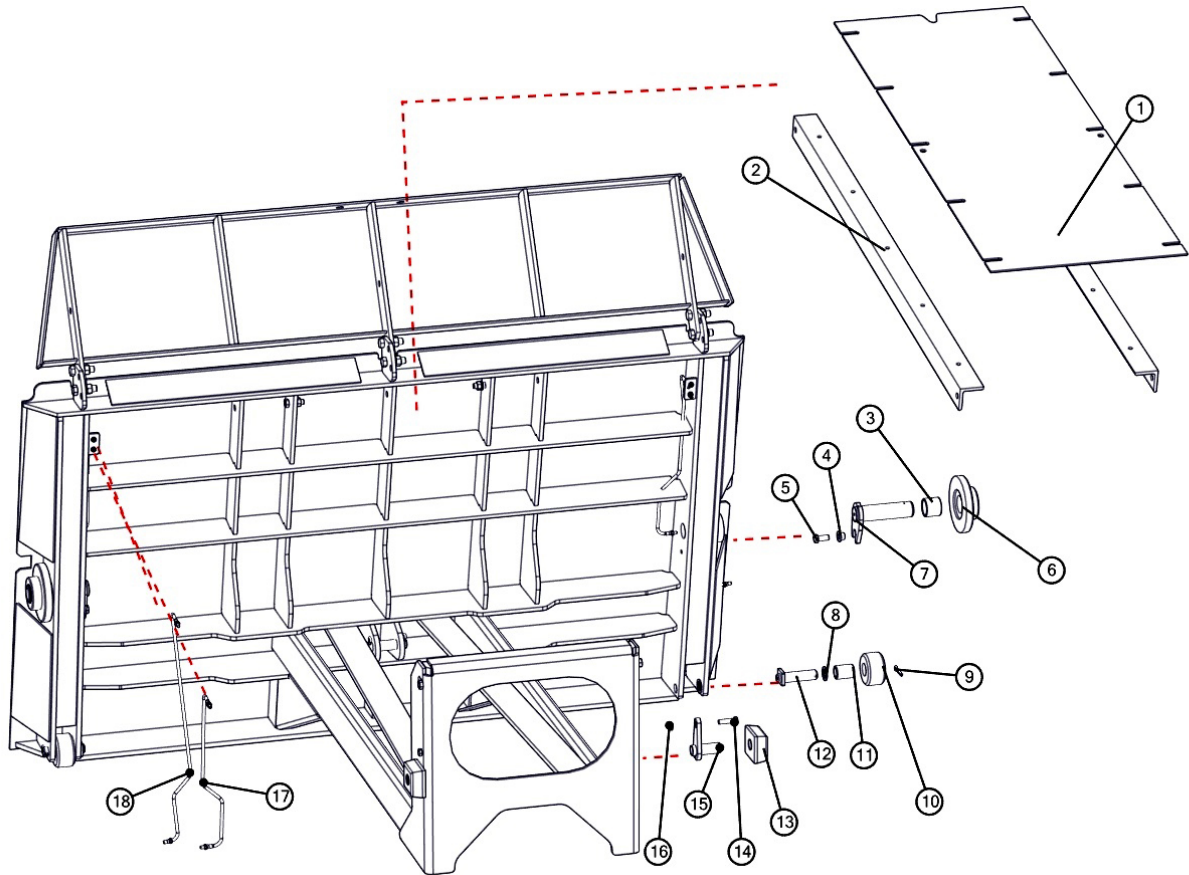

**ASHLAND SCRAPERS**
**Push-Off - 702014-702016-702015-140**

ITEM	PART	DESCRIPTION
1	502711	Dirt Shield: Push-off 140TS
2	123165-03	Brace: Push-off Dirt Shield Mount
3	A14039	Bushing: 2" ID X 2 3/8" OD X 2"L
4	A123358	Bushing: Pin Keeper w/flange
5	AFB-00079	Bolt: 5/8" X 1 1/2" Gr 8 Hex Cap
6	502049	Roller: Pushoff Hold Down
7	A123323-23	Pin: Upper Roller 2" X 7 7/8"
8	AFW-00015	Washer: 1 1/4" Flat
9	AFP-00010	Pin: 1/4" X 2" Cotter
10	A10164	Roller: Gate Front Hold Down
11	A10163	Bushing: Roller 1 1/4" X 1 3/4" X 2 3/8"
12	A123323-21	Pin: Lower Roller
13	A123353	Wear Pad: Pushoff Gate Slide
14	AFB-00144	Bolt: 1/2" X 2" Gr 8 Hex Cap
15	A123305A	Pin: 1 1/4" X 2 5/8" for Wear Pad
16	AFN-00011	Nut: 1/2" Hex
17	A125020	Grease Line: 32" Ass'y
18	A125021	Grease Line: 54" Ass'y

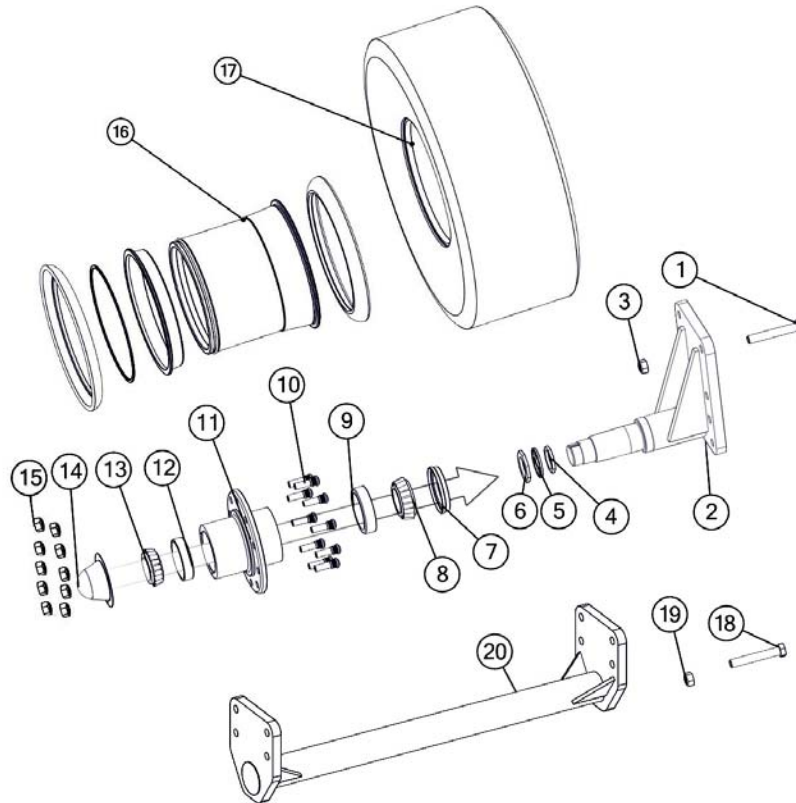

**ASHLAND SCRAPERS**
**Rear Wheel (140)**

ITEM	PART	DESCRIPTION
1	AFB-00017	Bolt: 1" X 6 1/2" Gr 8 Hex
2	092175	Spindle Assy: A14021 Spindle w/ gusset plate
3	AFN-00001	Nut: 1" Top Lock
4	A10172	Nut: Spindle Inner
5	A10049A	Collar: Spindle Lock Ring
6	A10048	Nut: Spindle Outer
7	A14011	Seal: Grease
8	A14015	Bearing: Cone Outer
9	A14014	Bearing: Cup Outer
10	400257	Stud: Wheel Gr 8
11	A14010A	Hub: 10 Hole
12	A14013	Bearing: Cup Inner
13	A14012	Bearing: Cone Inner
14	A14004	Hub Cap
15	A14006	Nut: Lug
16	A10039	Wheel: 26 X 16" Drop Center-10 Hole
17	ATI-00009	Tire: 18.4 - 26 ANS 12 Ply (R-3)
	A125338	Tire: 18.4 - 26 ANS 12 Ply Tire & Wheel Ass'y
18	AFB-00032	Bolt: 1" X 3 1/2" Gr 8 Hex Cap
19	AFN-00001	Nut: 1" Top Lock
20	091175-06	Support: Cross Pipe

**ASHLAND SCRAPERS**

**Apron Cylinder - A125050**

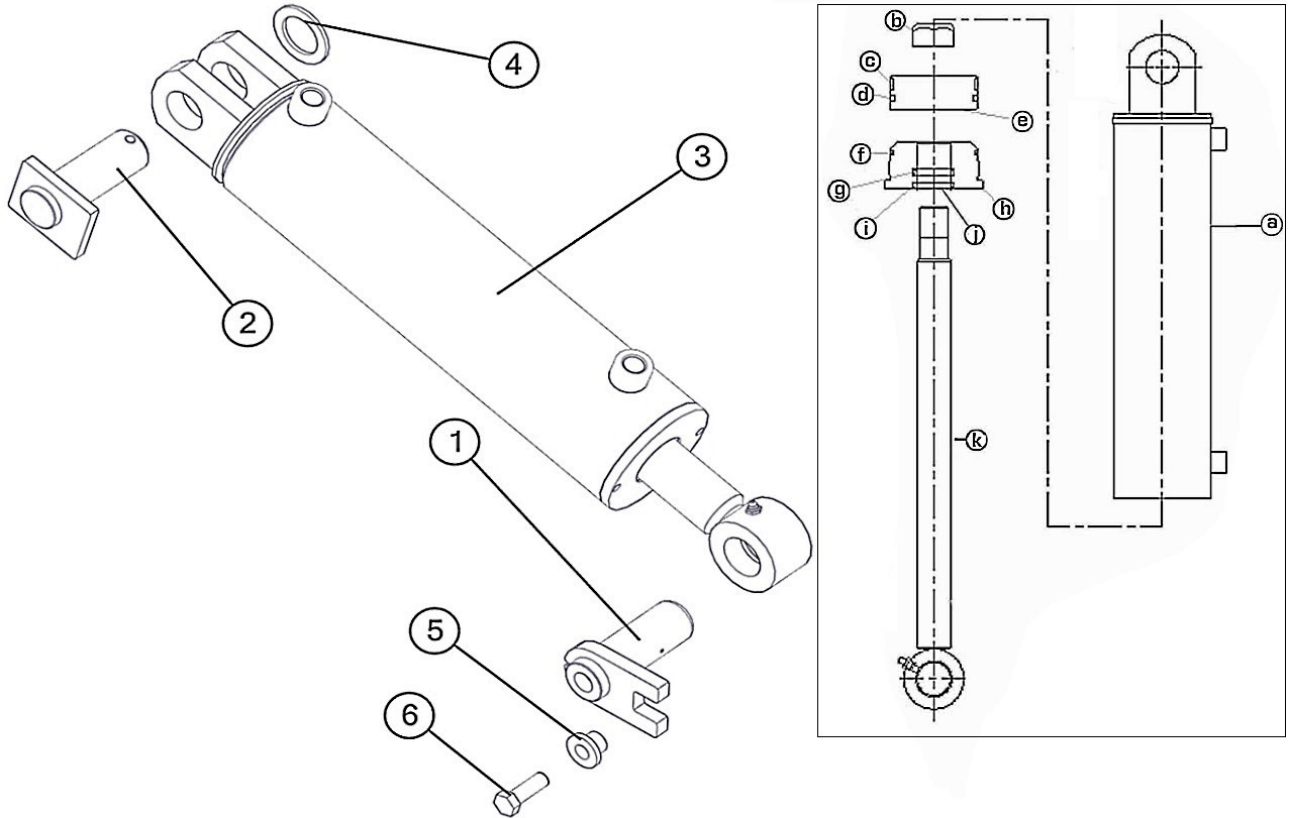

ITEM	PART	DESCRIPTION
1	A125050	APRON CYLINDER (4 X 13")
2	A123363	Pin: Apron Cylinder Base End, 1 1/2" X 4 1/8" (Greaseable)
3	A123362	Pin: Apron Cylinder Rod End, 1 1/2" X 4 1/2"
4	AFW-00016	Washer: 1 1/2" X 10 ga. NM bushing
5	A123351	Bushing: Pin Keeper 9/16" X 3/4 X 3/4"
5	AFB-00015	Bolt: 1/2" X 1 1/2" Gr 8
A	A125050-06	Barrel: for 4 X 13" Cyl.
B	A125050-04	Nut: Lock 1 1/8" NF
C	A125050-02	Piston: 4"
D	A125050-03	Gland
E	A125050-01	Rod: Piston 1 3/4" dia w 1 1/2" Eye
	A125050-05	Seal Kit Containing (f-k)
f		Nylon Wear Ring
g		FSP Seal
h		O-Ring
i		Backup Washer
j		Hallite Rod Seal
k		Snap in Rod Wiper

**Lift Cylinder - A123326**

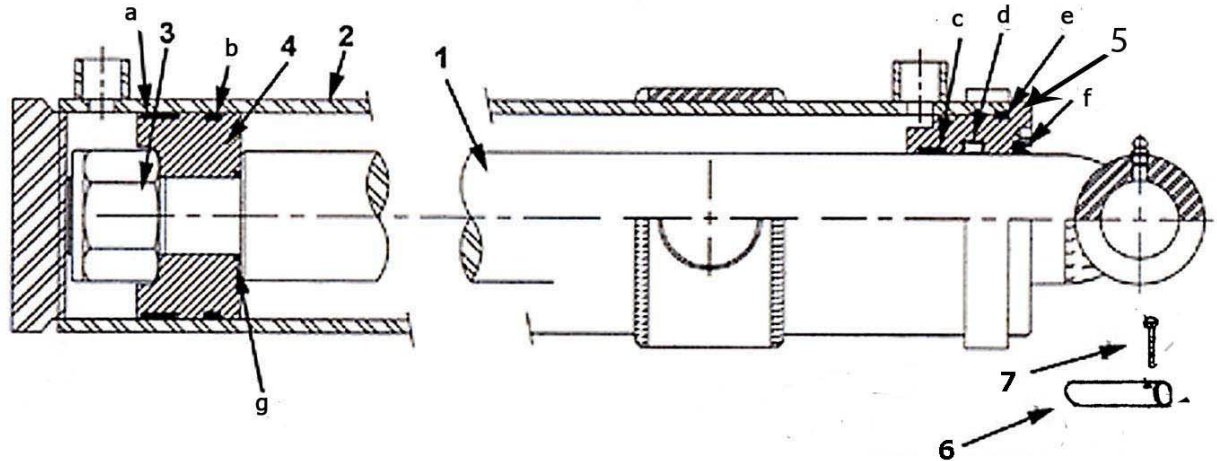

A350P018

ITEM	PART	DESCRIPTION
1	A123326-1	Piston Rod: 2 1/2"
2	A123326-2	Barrel Weldment
3	A125159-34	Nut: Lock 1 3/4 NF
4	A123324-4	Piston
5	A123324-5	Gland
6	A123335	Pin: Lift Cylinder
7	AFP-00001	Cotter Pin, 1/4 X 3"
	AHS-00140	Seal Kit (Items a-g)
a		Wear Band
b		Rod Seal
c		Wear Ring
d		Piston Seal
e		O-Ring
f		O-Ring
g		Rod Wiper

## Trunion Blocks

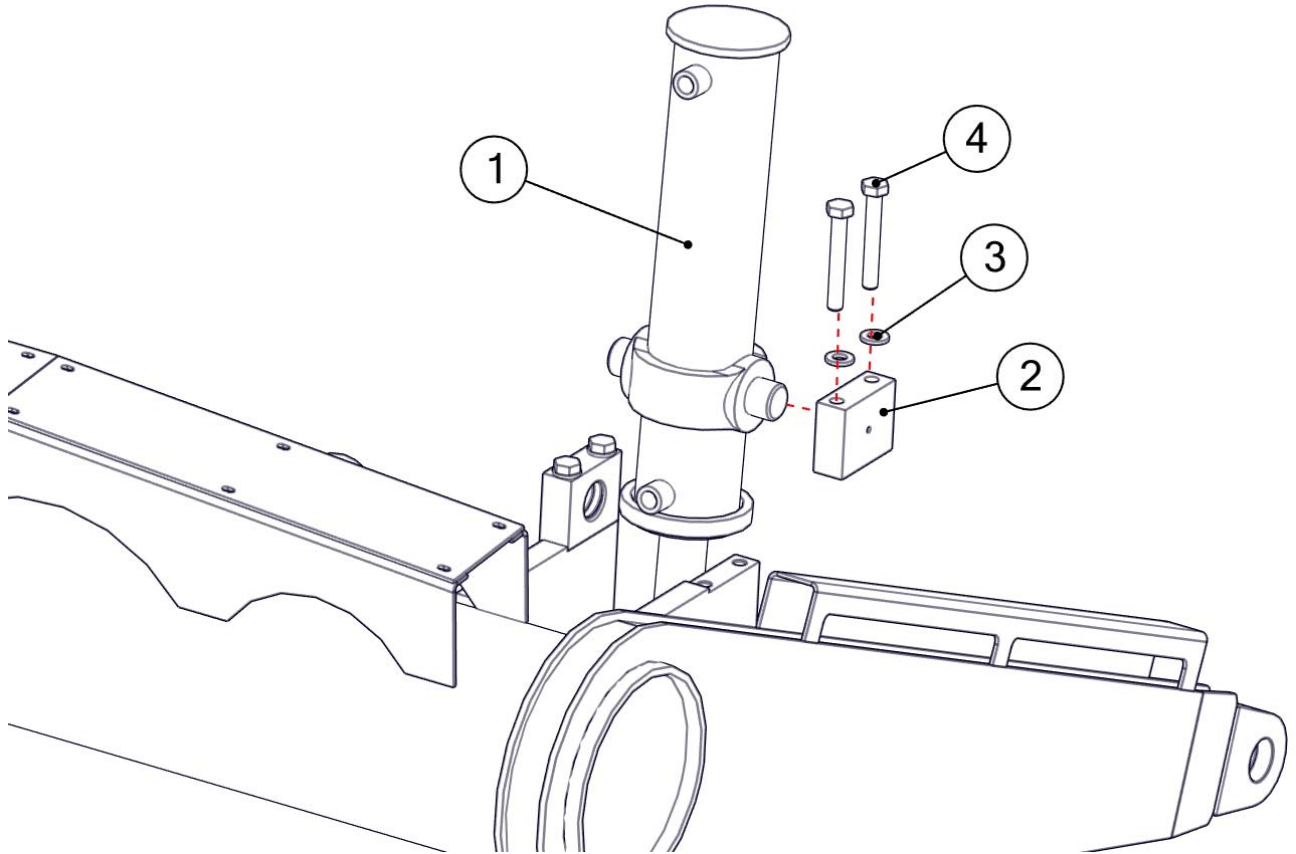

ITEM	PART	DESCRIPTION
1	A123326	Cylinder: 5 X 20" Trunion Mount
2	502143	Block: Trunion Mount
3	AFB-00039	Bolt: 3/4" X 5 1/2" Gr 8
4	AFW-00024	Washer: 3/4" Flat

**ASHLAND SCRAPERS**

**Push-Off Cylinder- 400045**

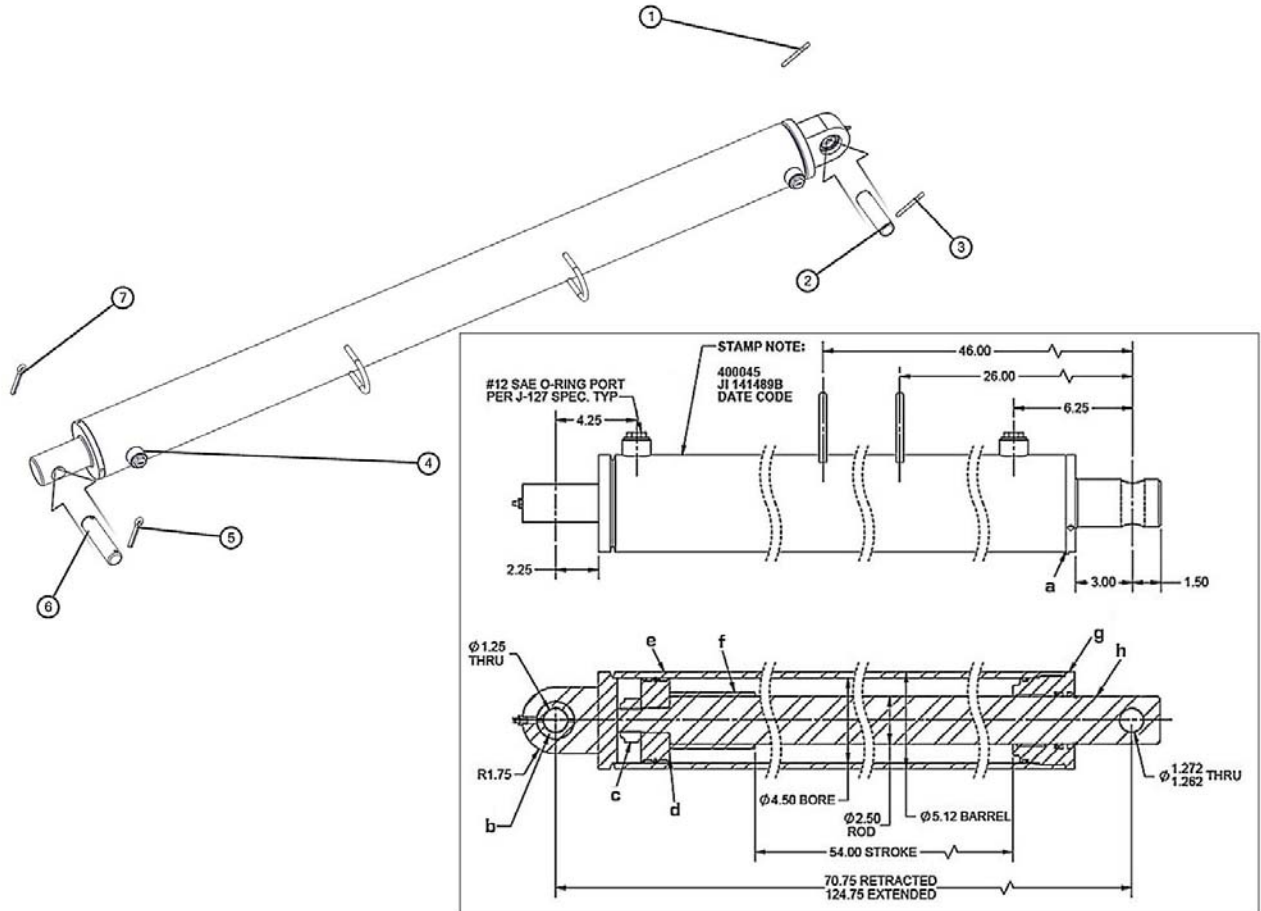

ITEM	PART	DESCRIPTION
1	400045	PUSH-OFF CYLINDER (4 1/2 x 54")
2	AFP-00010	Pin: 1/4" X 2" Cotter
3	A9024	Pin: 1 1/4" X 4 3/4"
4	A14033	Pin: 1 1/4" X 5 1/4"
a	711127A	Locking Screw
b	A125175-35	Bearing: 1 1/4" Cyl. Base
c	712025A	Nut: 1 1/4" Nylock
d	401405A	Piston: 4.5"
e	204145BP	Barrel
f	320750A	Stroke Limiter
g	500422BP	Gland
h	316480BP	Rod: 2.5"
	432570BSK	Seal Kit for Rod Bearing (Gland)

**Hydraulic Schematic**

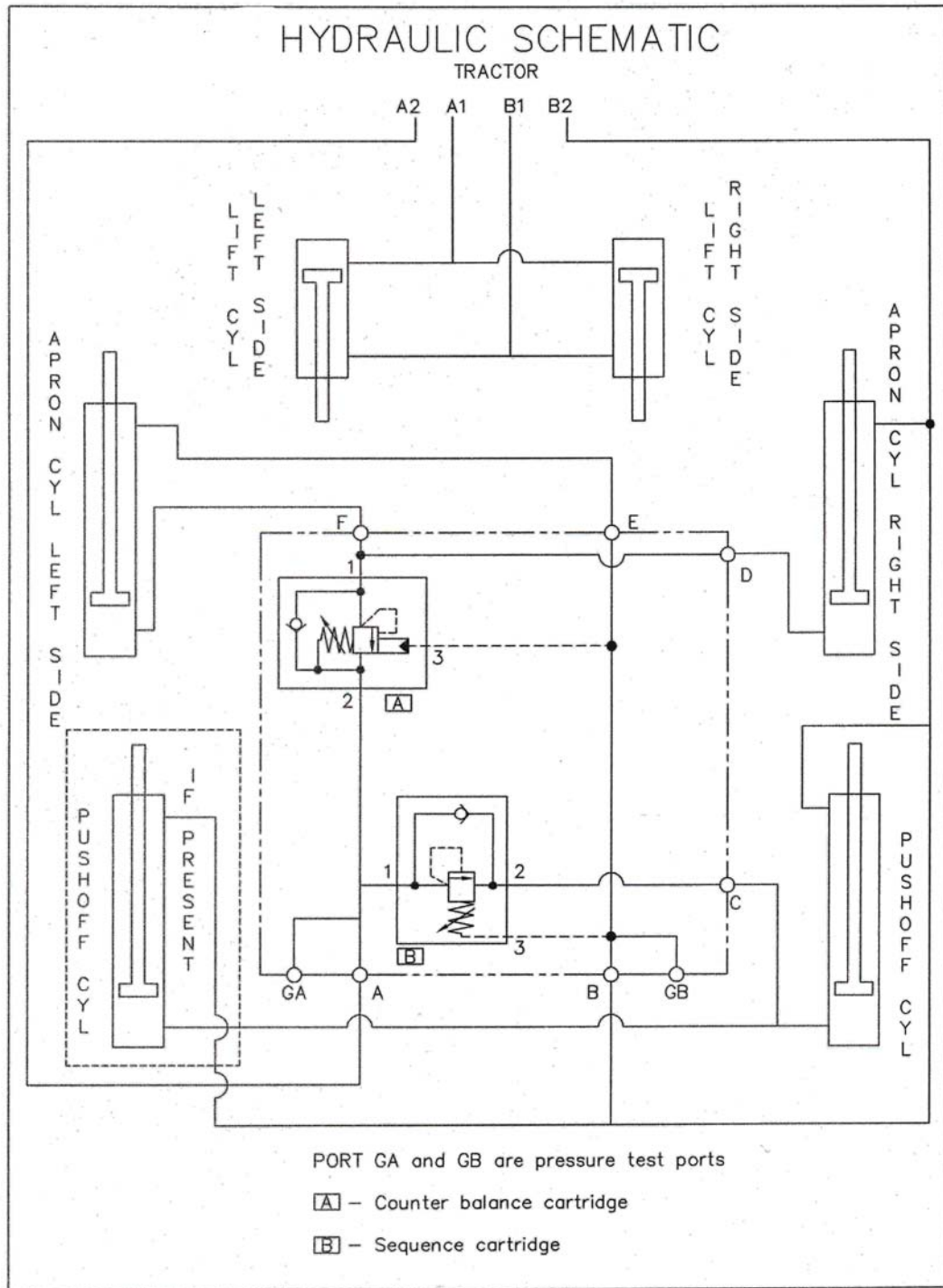

A400H003



## Hydraulic Accumulator

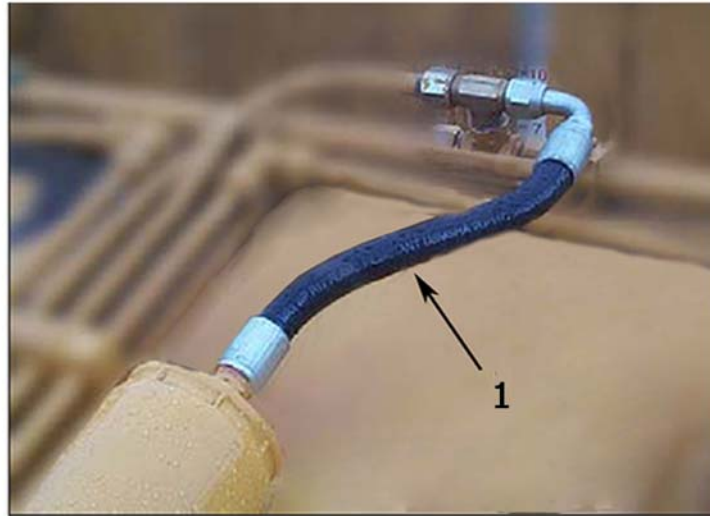

ITEM	PART	DESCRIPTION
1	A155H67	Hose, 3/4" X 16" MORB with sweep
2	A125009	Bracket, Welded with bolts
3	A125005	Accumulator Cylinder

**ASHLAND SCRAPERS**
**Hydraulic Manifold - A125174**

ITEM	PART	DESCRIPTION
1	A125162-02	PUSHOFF SEQUENCE CARTRIDGE
2	A125162-01	COUNTER BALANCE CARTRIDGE

**SETTING THE APRON AND PUSHOFF VALVE**

The manifold block containing the pushoff sequence valve cartridge and apron sequence valve cartridge is used to control two hydraulic circuits with one hydraulic remote. When the tractor hydraulic remote is activated, oil flows first to the apron cylinders until they are fully extended. Once the cylinders are fully extended, the apron circuits' hydraulic pressure begins to increase. Once the pressure threshold is surpassed (which is adjustable. See adjustment section), the sequence valve diverts the oil flow to the pushoff's hydraulic circuit. Once the push off is completely extended the operator then reverses the tractors hydraulic remote. The counterbalance valve will hold the apron open until the push off is fully retracted. The Apron sequence valve then opens and allows the apron to close.

**Setting the valves:**
**STEP 1 PUSHOFF SEQUENCE VALVE**

Loosen the lock nut (9/16") on the sequence valve cartridge. Turn the setscrew (4mm) clockwise until the front apron rises before the push-off begins to advance. (Earthmover should be empty) Turn the adjustment screw an additional 1/4 turn clockwise and tighten jam nut.

**STEP 2 COUNTER BALANCE VALVE**

Loosen the lock nut (9/16") on the counterbalance valve cartridge. Turn the setscrew (4mm) counter-clockwise until the apron holds in a raised position while rear gate is being retracted. Turn adjustment screw an additional 1/4 turn, tighten jam nut. DO NOT tighten adjusting screw more than necessary.



**Hydraulic Valve Ports**

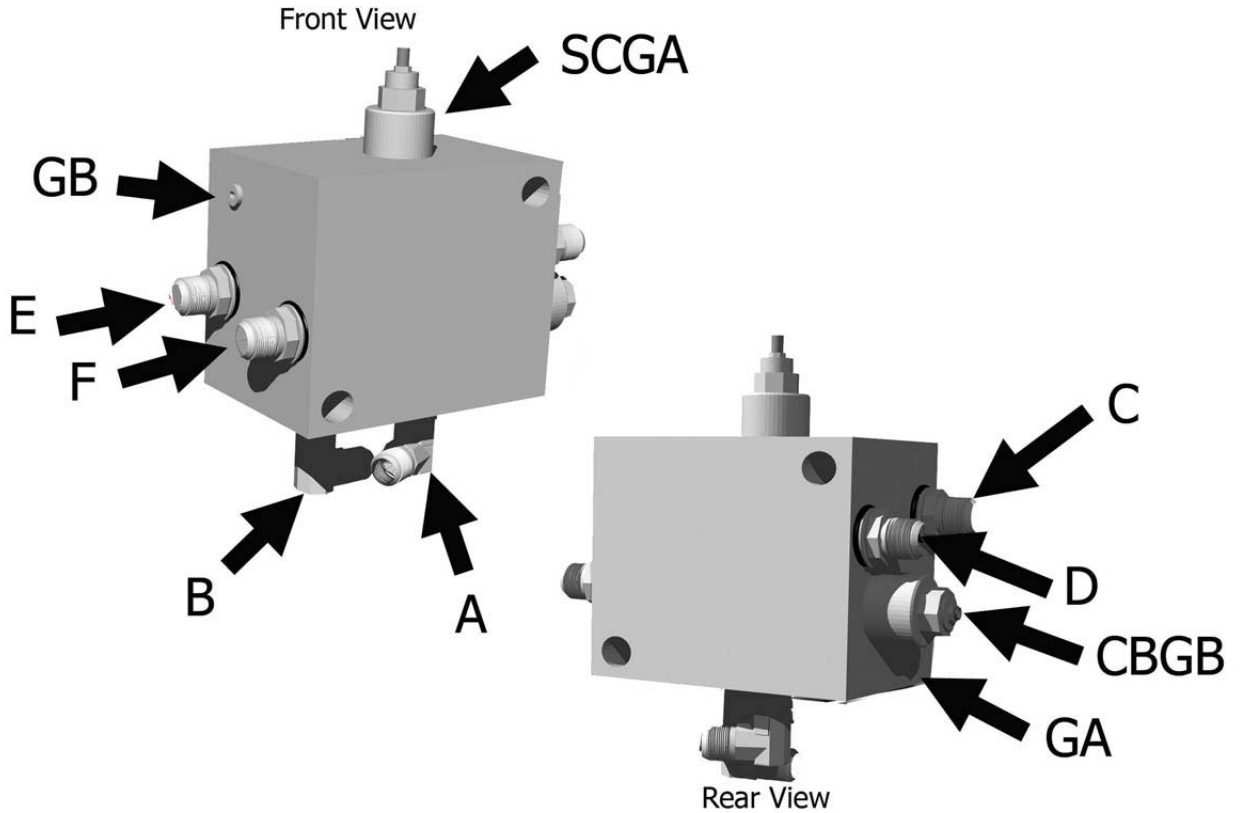

The lettering for the port locations are stamped on the block

A350P010

ITEM	PART	DESCRIPTION
A		Supply Line
B		Pushoff Cyl., (Rod End)-Apron Cyl., Right side (Base End)-Supply Line
C		Pushoff Cylinder, (Base End)
D		Apron Cylinder, Right side, (Rod end)
E		Apron Cylinder, Left side, (Base end)
F		Apron Cylinder, Left side, (Rod end)
CBGB		Counterbalance Valve, adjustable
SCGA		Sequence Valve, adjustable
GA		Pressure test port
GB		Pressure test port

**Hydraulic Valve Seals**

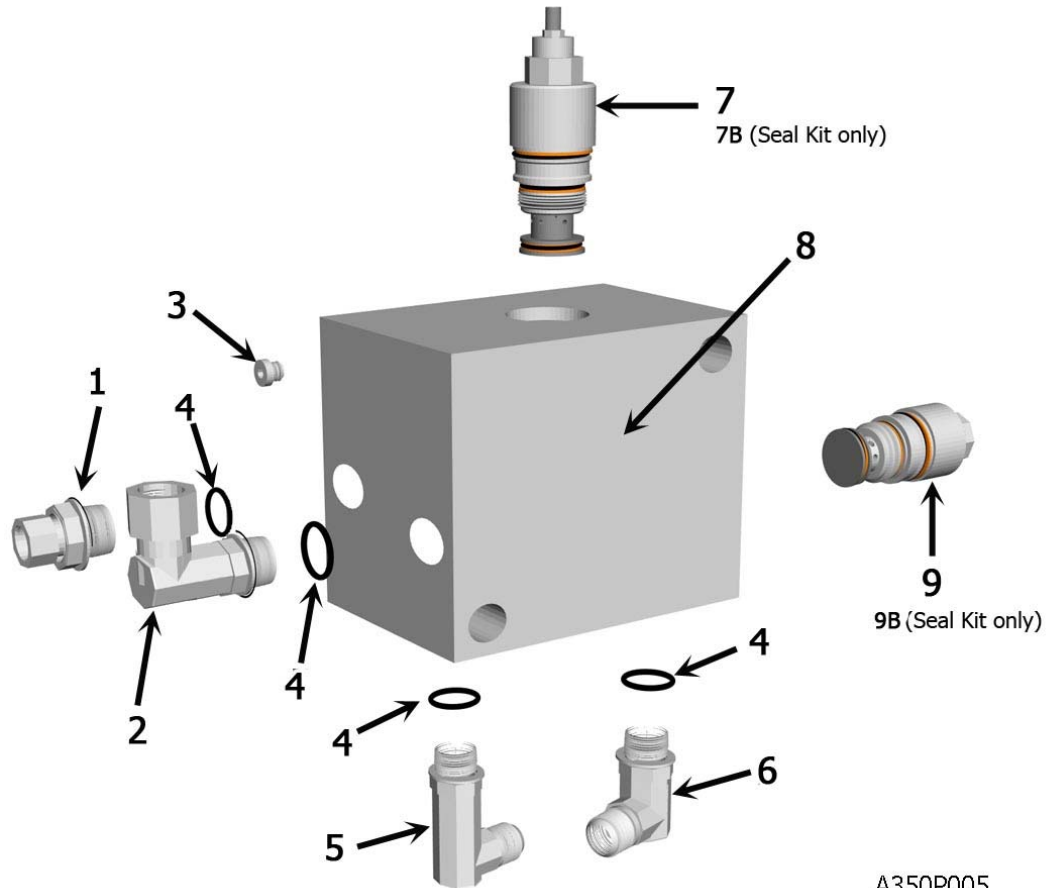

A350P005

ITEM	PART	DESCRIPTION
1	AHA-00043	Adapter: Str. Sw. 1 1/16 M ORB X 1/2 FP
2	AHA-00048	Adapter: 90 Deg. Swiv. 1 1/6 M ORB X 1/2 FP
3	AHS-00046	6 ORB Plug
4	AHS-00153	O-Ring for 12 M ORB Fitting
5	AHA-00047	Adapter: 90 Deg. XL 3/4 MJX 1 1/6 M ORB
6	AHA-00044	Adapter: 90 Deg. 3/4 MJ X 1 1/6 M ORB
7	A125162-02	Valve: Sequence Cartridge for Ver. III & IV
7b	A125162-02 KIT	Seal Kit for A125162-02 Valve Cartridge
8	A125174	Valve: Manifold Block IV Body
9	A125162-01	Valve: Counterbalance Cartridge for Ver. III & IV
9b	A125162-01 KIT	Seal Kit for A125162-01 Valve Cartridge

**ASHLAND SCRAPERS**

**Hydraulic Plumbing Clamps**

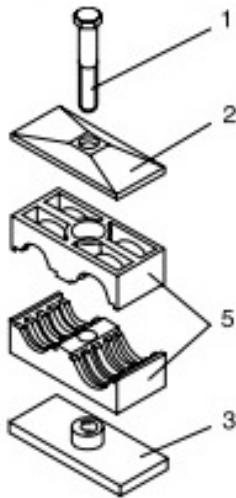

Twin Clamp with  
Weld Plate

AHL-00002

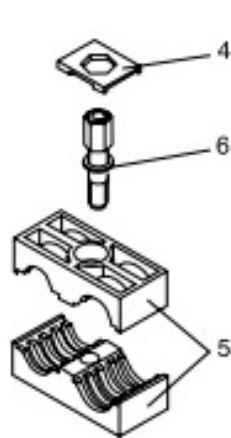

Twin Clamp  
Stacking Module

AHL-00022

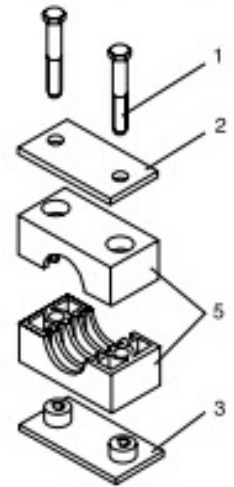

Single Clamp with  
Weld Plate

AHL-00001

**Parts Legend**

- |                 |                 |
|-----------------|-----------------|
| 1 Hex Head Bolt | 5 Clamp Pair    |
| 2 Top Plate     | 6 Stacking Bolt |
| 3 Weld Plate    |                 |
| 4 Safety Plate  |                 |

**ASHLAND SCRAPERS**

**Service: Grease Locations TS**



**ASHLAND SCRAPERS****Service: Grease Locations TS****Lubrication Points (see Ill.)**

1. Hitch – Horizontal and vertical pins.
2. Lift Cylinders – Rod end & Base End; Both left & right sides.
3. Front Arm Pivot Joint – Both left & right sides.
4. Apron Cylinders – Rod clevis pin; Both left & right sides.
5. Apron Pivot Pin – Both left & right sides.
6. Hold-down Rollers – Both left & right sides.
7. Floor Rollers – Both left & right sides.
8. Tapered Rollers – Both left & right sides.
9. Hubs

**ASHLAND SCRAPERS**
**Tire Inflation**

**TIRE INFLATION & TORQUE CHARTS**

TIRE INFLATION (PSI)				
Scraper Model	Front Tire Size (XL)	Max PSI	Rear Tire Size	Max PSI
25			11L-15.8 8 Ply	36
50			16.9-24 8 Ply	24
950	16.5L-16.1 10 Ply	36	16.9-24 8 Ply	24
140	550/45-22.5" 16 Ply	51	18.4-26 18 ply	28
140 LGP	550/45-22.5" 16 Ply	51	23.5-25 20 Ply	54
155	20.5-25 12 Ply	51	29.5-25 28 Ply	62
175	20.5-25 12 Ply	51	29.5-25 28 Ply	62
175 (Big Tire)	23.5-25 20 Ply	54	29.5-25 28 Ply	62
215 TS			20.5-25 20 Ply	62
220			20.5-25 20 Ply	62
2014CS				

On new machines, the wheels should be retorqued after the first two hours of use. Then check tires daily to ensure correct inflation levels. Check tire pressure with an accurate gauge having 6.9 kPa (0.07 bar) 1 psi) gradations. Check tires daily to ensure correct inflation levels. Also check for:

- Tire Damage
- Loose or missing wheel lugs, nuts or caps
- Uneven wear
- Damaged Rims

Torque Ft-lbs	Lug nuts (by model)
85-100	900-950
450	110-140
450	155-175 front
750	155-175 rear
750	220
750	2014
Torque Ft-lbs	Bolt Diameter
12	1/4"
25	5/16"
45	3/8"
70	7/16"
110	1/2"
150	9/16"
220	5/8"
380	3/4"
600	7/8"

**ASHLAND SCRAPERS****Maintenance Check List**

1. Grease all zerks.
  - a) Every 8 hours of operation.
  - b) See Lubrication Points section on next page.
  
2. Greasing the hubs.
  - a) Re-pack wheel bearings after 300 hrs of operation.
  - b) Completely clean grease out of hub and bearings every 1200 hours of operation.
  
3. Check tire pressure.
  - a) See Tire Pressure Chart.
  
4. Check all pins for signs of wear.
  - a) Daily
  
5. Check wheel lug nut torque.
  - a) After first 2 hours of operation.
  - b) Recheck daily for next 2 weeks.
  - c) Tighten wheel lug nuts in a star pattern.
  - d) Torque wheel lug nuts (See Torque Specifications).
  
6. Check and retighten all bolts.
  - a) After initial 10 hours of use.
  - b) Again after 50 hours of use.
  - c) See Torque Specifications.
  
7. Inspect cutting edges.
  - a) Daily
  - b) Replace cutting edges when center blade has been worn to approximately 6" and side edges worn to approximately 4".



**CAUTION!** Failure to replace worn cutting edges may result in unnecessary wear to the earthmover sides and floor.

Note: Please specify left or right "L" shaped cutting edges when ordering replacements. Left or right side parts are determined by viewing from rear of the scraper.

**ASHLAND SCRAPERS****Service: Tire Service**

**The task of servicing tires and wheels can be extremely dangerous and should be performed by trained personnel only, using the correct tools and following specific procedures. Do not attempt to mount, demount or inflate a tire if you do not have the proper equipment and experience to perform the job. Call a qualified repair service to inspect the assembly and make necessary repairs. Failure to heed warnings could lead to serious injury or death.**

Visually inspect tires and wheels daily. Carefully inspect any rim and tire assembly that has been run underinflated or flat before reinflating the tire to make sure there is no damage to either the rim or tire.

- ALWAYS wear personal protection equipment such as gloves, footwear, eye protection, hearing protection and head gear when servicing tire and wheel components.
- DO NOT operate with damaged rims, tire cuts or bubbles, missing lug bolts or nuts or damaged rims.
- ALWAYS maintain the correct tire pressure. NEVER exceed recommended tire inflation pressure.
- INSPECT any rim and tire assembly that has been run flat or severely underinflated before reinflating the tire. Damage to the rim and tire may have developed.
- NEVER inflate a tire that has lost air pressure or has been run flat without determining and correcting the problem.
- NEVER try to repair wheel, rim, or tire components parts. Parts that are cracked, worn, pitted with corrosion, or damaged must be discarded, and replaced with good parts.
- ALWAYS use approved tire and rim combinations for the model scraper that you have and verify that part numbers of components are correctly matched for the assembly.
- ALWAYS exhaust all air from the tire prior to demounting.
- ALWAYS place wheel and tire assemblies in restraining devices (safety cage) when inflating tires. Use a clip-on chuck and long extension hose to allow you to stand to the side of the tire and not in front of it.
- NEVER weld or cut on an inflated tire assembly. Welding heat can cause increased pressure which could result in tire explosion.
- ALWAYS use proper lifting techniques, and mechanized lifting aids to move heavy components and assemblies.
- NEVER leave a tire, wheel, or assembly unsecured in a vertical position.
- ALWAYS take care when moving tires and wheels that other people in the area are not endangered.



**ASHLAND SCRAPERS****Troubleshooting**

With proper care and maintenance, your Ashland Scraper will give many years of reliable service. When a situation arises where the earthmover performance is not satisfactory, this section will give some pointers on finding and correcting the problem.

---

**Grease zerk will not take grease.**

---

1. Grease zerk plugged.
  - a) Remove and replace grease zerk.
2. Pin is frozen.
  - a) Remove, clean, and inspect pin.
  - b) Replace pin if necessary.
3. Bushing grease passage is not aligned with grease zerk.
  - a) Remove, clean, inspect, and realign bushing.
  - b) Replace bushing if necessary and realign.

---

**Push-off rollers do not roll.**

---

1. The rollers need lubrication.
  - a) Check zerk hole and grease.
  - b) Remove pin, clean, inspect, and replace if necessary.
2. The roller bushing is worn out.
  - a) Remove roller assembly and replace bushing.
  - b) See parts manual.

---

**Cylinders will not hold in preset position, i.e. the cylinder creeps.**

---

1. Seals leaking internally.
  - a) Remove and replace seal kit.

---

**Machine cuts unevenly.**

---

1. Cutting edges worn unevenly.
  - a) Replace cutting edges.
2. Improperly inflated tires.
  - a) Check air pressure in tires.

**ASHLAND SCRAPERS****Warranty Statement**

Ashland Industries Inc. warrants each new product to be free from defects in material and workmanship. This warranty is applicable only for the normal service life expectancy of the product or components, not to exceed **six consecutive months** from the date of delivery of the new Ashland Industries product to the purchaser, or the date the product is first put into service via a rental agreement or other means, whichever occurs first.

The major components of swivel hitches used on Industrial series scrapers are warranted for three consecutive months from the date of delivery of the new Ashland Industries product to the purchaser, or the date the product is first put into service via a rental agreement or other means, whichever occurs first, except those components described below.

Genuine Ashland Industries Inc. replacement parts and components will be warranted for 30 days from date of purchase, or the remainder of the original equipment warranty period, whichever is longer.

Under no circumstances will it cover any merchandise or components thereof, which in the opinion of the company, has been subjected to misuse, unauthorized modification, alterations, an accident or if repairs have been made with parts other than those obtained through Ashland Industries Inc.

Ashland Industries Inc. in no way warrants Tires since their respective manufacturer warrants these items separately. Please call Ashland Industries Inc. to receive phone numbers of tire suppliers.

Ashland Industries Inc. in no way warrants wearable items such as cutting edges, front dolly wheel balls, socket halves, rollers, bushings, yoke hitch pins, hitch bushings, etc..

Our obligation under this warranty shall be limited to repairing or replacing, free of charge to the original purchaser, any part that, in our judgment, shall show evidence of such defect, provided further that such part shall be returned within 30 days from the date of failure to Ashland Industries Inc. routed through the dealer and distributor from whom the purchase was made, transportation charges prepaid. Upon warranty approval proper credits will be reimbursed for transportation.

This warranty shall not be interpreted to render Ashland Industries Inc. liable for injury or damages of any kind or nature to person or property. This warranty does not extend to the loss revenue, extra labor cost associated with downtime, substitute machinery, rental or for any other reason.

Except as set forth above, Ashland Industries Inc. shall have no obligation or liability of any kind on account of any of its equipment and shall not be liable for special or consequential damages. Ashland Industries Inc. make no other warranty, expressed or implied, and, specifically, Ashland Industries Inc. disclaims any implied warrant or merchantability or fitness for a particular purpose. Some states or provinces do not permit limitations or exclusions of implied warranties or incidental or consequential damages, so the limitations or exclusion in this warranty may not apply.

This warranty is subject to any existing conditions of supply which may direct affect our ability to obtain materials or manufacture replacement parts.

Ashland Industries Inc. reserves the right to make improvements in design or changes in specifications at any time, without incurring any obligation to owners of units previously sold.

No one is authorized to alter, Modify or enlarge this warranty nor the exclusion, limitations and reservation .

Warranty Department