

# **ASHLAND INDUSTRIES**

## Parts Manual

04-17

# ***175XL2-004***



1115 Rail Drive  
P.O. Box 717  
Ashland, WI U.S.A.  
Toll Free: (877) 634-4622  
Business: (715) 682-4622  
Fax: (715) 682-9717

***Ashland Industries***  
*Crafting Quality since 1953!*

[www.ashlandind.com](http://www.ashlandind.com)  
[www.scraperdrawing.com](http://www.scraperdrawing.com)

# Table of Contents

## Categorized Listing

<b>ASHLAND SCRAPERS</b>	<b>1</b>
Introduction	1
Operation and Maintenance	2
Safety Guidelines	5
Assembly - Main - WG-175X-002	6
Apron - 700029	7
Ball Socket - 601065	8
Bowl & Frame - 701024	9
Front Section - 700039	11
Front Section - Bracket (175)	12
Pole - Axle - 700052	13
Push-Off - 702018	14
Front Wheel (175)	16
Rear Wheel (155-175)	17
Apron Cylinder - A125050	18
Lift Cylinder- (400226)	19
Push-Off Cylinder - 400225	20
Decals (175XL-001)	21
Hydraulic Schematic	22
Hydraulic Manifold - A125174	23
Hydraulic Valve Ports	24
Hydraulic Valve Seals	25
Hydraulic Plumbing Clamps	26
Service: Grease Locations XL	27
Scraper Specifications 175XL2	29
Tire Inflation	30
Maintenance Check List	31
Service: Tire Service	32
Troubleshooting	33
Warrantee Statement	34

---

# Table of Contents

## Alphabetized Listing

<b>A</b>	
Apron - 700029	7
Apron Cylinder - A125050	18
ASHLAND SCRAPERS	1-34
Assembly - Main - WG-175X-002	6
<b>B</b>	
Ball Socket - 601065	8
Bowl & Frame - 701024	9
<b>D</b>	
Decals (175XL-001)	21
<b>F</b>	
Front Section - 700039	11
Front Section - Bracket (175)	12
Front Wheel (175)	16
<b>H</b>	
Hydraulic Manifold - A125174	23
Hydraulic Plumbing Clamps	26
Hydraulic Schematic	22
Hydraulic Valve Ports	24
Hydraulic Valve Seals	25
<b>I</b>	
Introduction	1
<b>L</b>	
Lift Cylinder- (400226)	19
<b>M</b>	
Maintenance Check List	31
<b>O</b>	
Operation and Maintenance	2
<b>P</b>	
Pole - Axle - 700052	13
Push-Off - 702018	14
Push-Off Cylinder - 400225	20
<b>R</b>	
Rear Wheel (155-175)	17
<b>S</b>	
Safety Guidelines	5
Scrapper Specifications 175XL2	29
Service: Grease Locations XL	27
Service: Tire Service	32
<b>T</b>	
Tire Inflation	30
Troubleshooting	33
<b>W</b>	
Warrantee Statement	34



## Introduction

Thank you for choosing an Ashland scraper for your earthmoving needs. Years of research, testing and successful application have been spent to ensure quality and maximum performance for our customers.

### QUALITY POLICY

**It is our mission to exceed our customers' expectations in quality, delivery, and cost through continuous improvement and customer interaction.**

Please read and understand this manual before attempting to attach or operate this scraper. This manual should always remain with the machine. Be sure and fill out and send in the owners registration form at the beginning of this manual, or you may fill out the form on-line by going to [ashlandind.com](http://ashlandind.com) and click on "Register your Machine" in the parts section drop-down. If you have questions, please feel free to call or email us. You can visit us on-line at [www.ashlandind.com](http://www.ashlandind.com).

Ashland Industries hours of operation are 8:00 a.m. to 5:00 p.m. CST. We can be reached toll free at: 877-634-4622.

### SCRAPER ID NUMBER

The serial number plate for the scraper is located on the right rear area of the scraper. The letter and numbers stamped identify the serial number, model number and capacity of the scraper. Please record this serial number for use in ordering parts, warranty issues and to track your equipment if it is ever stolen.

References to serial number breaks on parts are located in the manual with a reference sequence of XXXXX-XXXXX. The beginning number records the serial number start of the use of that part. The ending number is the final serial number use of the part within this machine.



### IMPORTANT

Parts must be ordered through your local authorized ASHLAND dealer. Be sure to state MODEL and SERIAL NUMBER of your machine. Ashland Industries weldable replacement parts are also available to rebuild, modify or update your scraper to current factory specifications.

**ASHLAND SCRAPERS****Operation and Maintenance**

Your Ashland scraper is a durable piece of equipment and with proper care will yield many years of trouble free operation. However, the life of your scraper can be severely shortened by poor maintenance. You must follow consistent maintenance practices and use good quality grease and hydraulic oil (compatible with the power unit's hydraulic system) to insure the longer, most productive use from your scraper.

Your scraper should be greased at all points where grease fittings are provided. **REMOVE TRANSPORT LOCKS** prior to operation. Next, extend and retract all cylinders several times to force out any air from the hydraulic cylinders and lines. Check the oil levels in the tractor hydraulic system and add to maintain the proper level. Care should be used when adding oil or when disconnecting any oil line to keep all dirt out of the oil as dirt is a major factor in the failure of hydraulic components.

When your scraper is placed into operation, the operator will have to "feel out" the amount of depth of cut to obtain maximum loading efficiency. This is usually accomplished by taking a lesser and more uniform cut; however, some soil conditions such as loose sand may require a "pumping action" obtained by taking successive deep cuts and lifting out of cut as the tractor begins to lose power or traction.

- After 8 hours of operation, all bolts should be checked and tightened if necessary and all grease fittings lubricated. Check tire pressures daily. Also, check pins and cutting edges for signs of wear.
- After 50 hours work, all bolts should be rechecked and tightened if necessary. Check wheel bearings and adjust if necessary.
- Check wheel lug nut torque.
  - After first 2 hours of operation.
  - Recheck daily for the next 2 weeks.
  - Tighten wheel lug nuts in a star pattern.
  - Torque wheel lug nut (see Torque Specifications).
- After 300 hours work, clean and repack wheel bearings and replace, if necessary, cutting edges, worn pins, etc.



**Failure to replace worn cutting edges may result in unnecessary wear to the earthmover sides and floor.**

**ASHLAND SCRAPERS****Operation and Maintenance**

Before starting a job, make sure Diggers Hot Line has been contacted and all underground utilities have been properly located (electric, phone and pipelines). Have a clear understanding of all local, OSHA and MSHA rules that apply to the job. Beware of your environment and keep others a safe distance from the machine while familiarizing yourself with the machine's controls. The scraper requires a power source with **TWO** 4-way (double acting) hydraulic control valves.

**Scraper damage can occur if:**

1. The scraper is running over the haul road with the bowl fully raised. On scrapers that have factory installed nitrogen over hydraulic accumulators, the lift cylinders should be lowered 3 to 4 inches to allow the cushioned ride to work properly.
2. The heaped payload repeatedly exceeds the design ISO 6485 Earth-moving machinery-Tractor-scraper volumetric rating.
3. The fully loaded scraper exceeds the 10 mph on smooth haul roads and dramatically less on uneven haul roads.
4. The scraper is being top-loaded without the bowl being fully lowered to the ground prior to placing the material into the bowl.
5. The scraper is being used to level haul roads with the apron closed, not allowing material to enter the bowl.
6. The scraper is being used to load rock.
7. The scraper is being aggressively push loaded with a dozer.
8. A power unit that is above the horsepower rating is pulling the scraper.

These types of damage are not covered by warranty. Warranty only covers defects in material or workmanship and not abuse because of improper use.

**Know the job:**

1. Know the weight of the material to be moved.
2. Lay the job out to take advantage of grades when loading, if possible.
3. Keep hauls as short as possible.
4. Keep haul roads smooth.
5. If more than one unit is on the job, make sure the haul roads are one way and that the operators understand the direction.
6. Brief the operators as to what the job consists of so there is not misunderstanding.
7. Know the moisture content in the material to be moved.
8. Will water be needed for proper compaction?
9. Will drainage be a problem?
10. How many units will be needed to efficiently complete the job?

**Transport the scraper safely:**

1. Always empty scraper.
2. Clean all material from exterior of scraper.
3. Make sure all road rules are followed.
4. Use proper lighting and flagging.
5. Lower scraper bowls to provide just enough clearance over obstacles.
6. Transport at a safe speed to avoid roll over.
7. Reduce speed on curves and when going downhill.

**ASHLAND SCRAPERS****Operation and Maintenance****Apron Opening Guidelines:**

You will need to determine the ideal opening for your soil condition. It is important to have the apron opened prior to loading. To receive the highest production possible, it is important to know the general characteristics of the material that you will be loading. In heavier soils like clay or gumbo, the soil will slab up and remain together after being cut by the blades. In lighter soils, like sand or dry loose top soil, the material will pile up or push after being cut by the blade. Use the suggestions listed below:

**Topsoil with heavy vegetation (12" to 24" opening):**

When cutting undisturbed soils, you will need to open the apron high enough to allow debris to easily enter the scraper bowl. If the apron is opened too high, the rolling up sod will fall out past the apron and hinder the incoming material. If the apron is not adjusted quick enough, the material will bunch or push ahead of the machine. If this happens, you should close the apron and pull out the cut quickly. If you wait too long, you may develop too large a pile to clear the scraper while rising out of the cut. This can cause the power unit to lose traction and possibly cause you to get stuck.

**Clay or loamy material: (6" to 12" opening):**

To cut clay or loam soils, lower the apron to approximately 6" to 12" between the blades and the bottom of the apron. When you first lower the bowl, you'll see the material being cut by the blades and entering the bowl. As you continue to move forward, small clumps will fall past the apron and develop a small pile ahead of the apron. By limiting this apron opening, the small pile will "blade off" any loose material ahead of the machine. Adjustments should be made if large objects such as rocks or deep gouges are within the cut.

**Sand or loose topsoil (15" to 30" topsoil):**

Loading sand or loose top soil is the most difficult type of soil to load. In combination with the larger apron opening, you'll want to operate at a faster ground speed. By traveling faster and lowering the blade deeper than normal, it forces the material into the scraper bowl.

We encourage you to experiment with different apron openings to determine the best condition for your jobsite.



The Apron is designed to capture material inside of the scraper bowl and should not be used as a large blade. Obstructions like large rocks or dense piles may cause the apron to bend inward after prolonged exposure to these conditions.



## Safety Guidelines



**Safety Signal Words:** Please note the use of signal words such as DANGER, WARNING, and CAUTION paired with the safety messages on your scraper. The appropriate signal word for each safety message has been selected using the following guidelines:

- **Danger:** Indicates an imminently hazardous situation that, if not avoided, will result in death or serious injury. This signal word is limited to the most extreme situations—typically for machine components which, for functional purposes, cannot be guarded.
- **Warning:** Indicates a potentially hazardous situation that, if not avoided, could result in death or serious injury. For example, hazards that are exposed when guards are removed. This signal word may also be used to alert against unsafe practices.
- **Caution:** Indicates a potentially hazardous situation that, if not avoided, may result in minor or moderate injury. This signal word may also be used to alert against unsafe practices.

Operator safety is a main concern in designing and developing equipment. Designers and manufacturers include as many safety features as possible. However, every year many accidents occur which could have been avoided by extra thought and a more careful approach to handling equipment. The operator can avoid many accidents by observing the precautions in this section. To avoid personal injury, study the following precautions and insist those working with, or for you, follow them.

Replace any CAUTION, WARNING, DANGER or instruction safety decal that is not readable or missing. Locations of decals are indicated in this booklet.

Do not attempt to operate this equipment under the influence of drugs or alcohol.

Review the safety instructions in the operator's manual with all users annually.

**Operators should be responsible adults who are familiar with machinery and trained in the equipment's operations. Do not allow persons to operate or assemble this unit until they have read this manual and the owner's manual and have developed a thorough understanding of the safety precautions and scraper operation.**

**ASHLAND SCRAPERS**

**Assembly - Main - WG-175X-002**

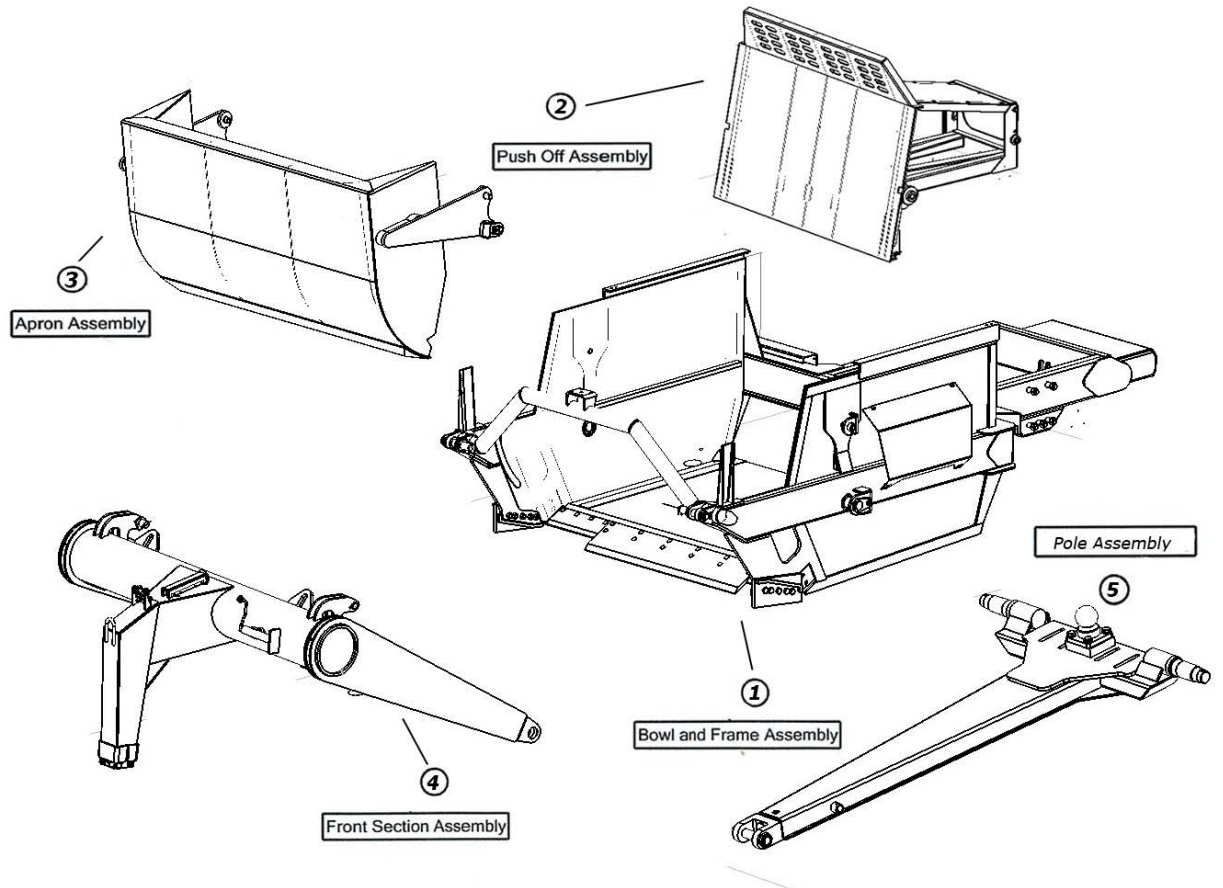

ITEM	PART	DESCRIPTION	SN 175XL2
1	701024	Bowl and Frame Assembly	
2	702018	Push-Off Assembly	
3	700029	Apron Assembly	
4	700039	Front Section Assembly	
5	700052	Pole Assembly	

**Apron - 700029**

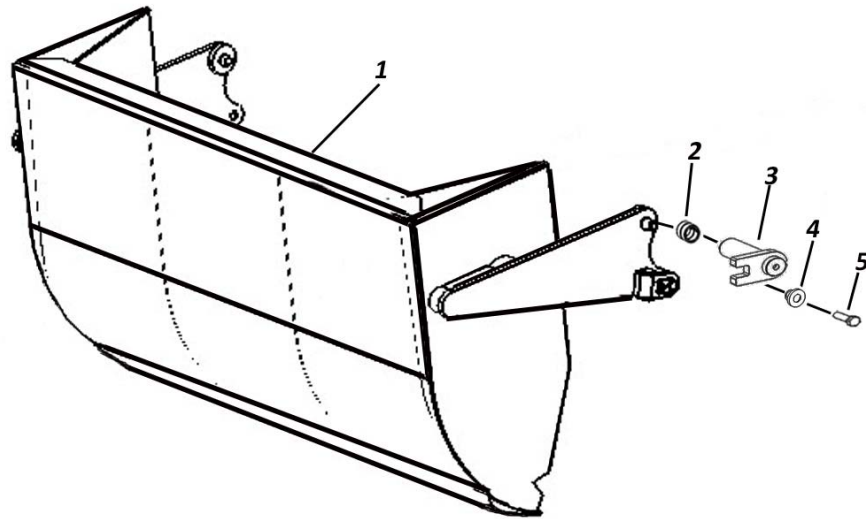

ITEM	PART	DESCRIPTION	SN 175XL2
1	700029	APRON -175	
2	A16027	Bushing	
3	600993	Apron Pivot Pin	
4	A123351	Bushing: Pin Keeper	
5	AFB-00015	Bolt: 1/2-13 X 1 1/2" Hex Cap	

**Ball Socket - 601065**

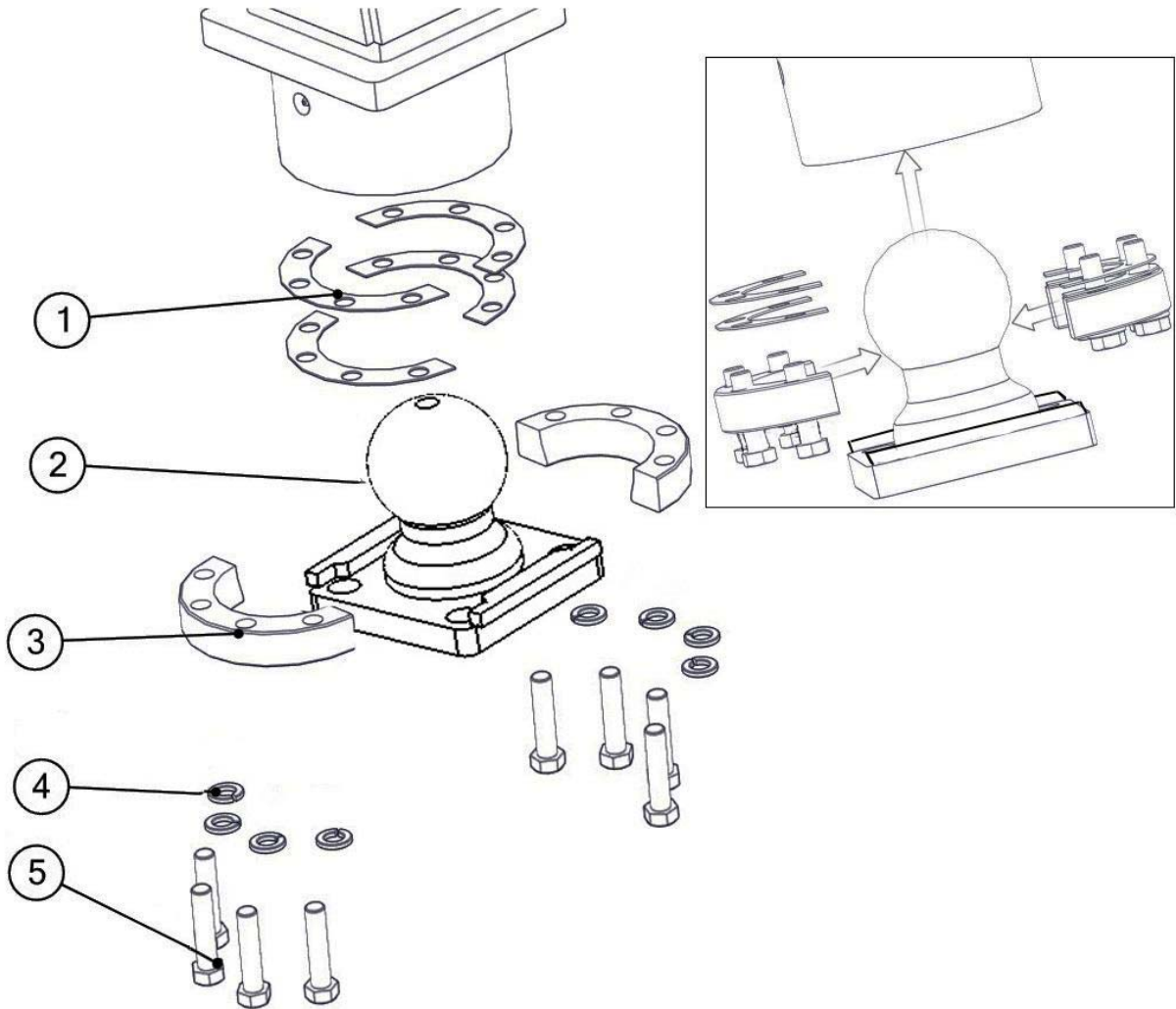

ITEM	PART	DESCRIPTION	SN 175XL2
1	502738	Shim: Ball Socket Spacer	
2	601065	Ball Hitch: w/ locking tab	
3	502660	Retainer: Flanged	
4	AFW-00031	Washer: 5/8" Lock	
5	AFB-00063	Bolt: 5/8 X 2 1/2" Gr 8 Hex Cap	

## Bowl & Frame - 701024

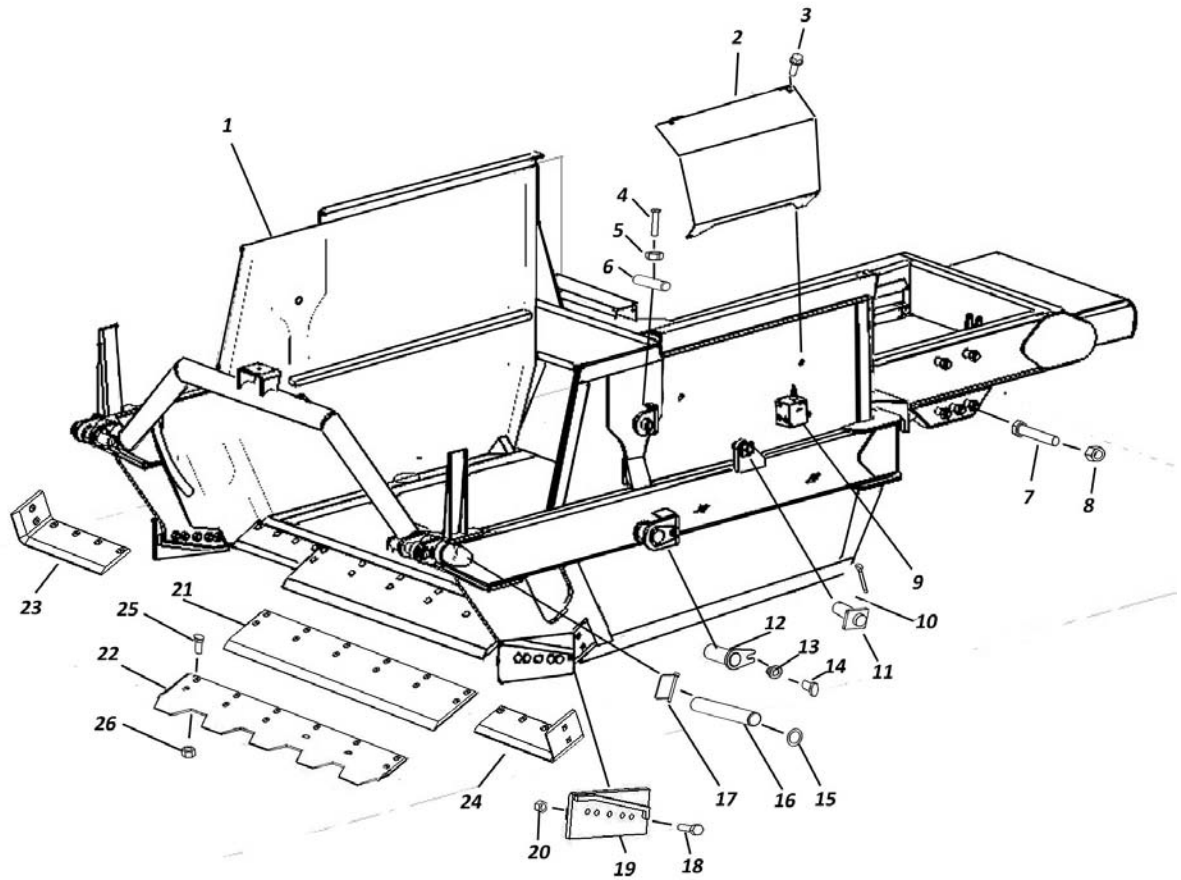

Blade Bolts Required:	Bolts	Nuts	Qty ea
A123330 (& Ser)	PB9B-NC-088-0275	AFN-00019	12
A123332 (L & R)	PB9P-NC-088-0275	AFN-00019	6
A123357	AFB-00018	AFN-00012	4

ITEM	PART	DESCRIPTION	SN 175XL2
1	701024	BOWL & FRAME	
2	501896	Dirt Shield-Left	
3	AFB-00170	Bolt: 3/8-11 X 1" Hex Cap	
4	AFB-00015	Bolt: 1/2 X 1 1/2" Gr 8 Hex Cap	
5	A123351	Bushing: Pin Keeper	
6	600993	Pin: Apron Pivot	
7	AFB-00067	Bolt: 1 1/4"-12 X 7 1/2 Hex Cap	
8	AFN-00029	Nut: 1 1/4"	
9	A125174	Valve: Manifold Block	
10	AFP-00002	Cotter Pin	
11	A123363	Pin: Apron Cyld. End	
12	A123321-09	Pin: Main Frame	
13	A123358	Bushing: Pin Keeper	
14	AFB-00079	Bolt: 5/8"-11 X 1 1/2" Hex Cap	
15	AFW-00014	Washer: 2"	

**ASHLAND SCRAPERS****Bowl & Frame - 701024**

ITEM	PART	DESCRIPTION	SN 175XL2
16	A123335	Pin: Lift Cylinder Rod End	
17	A125006	Pin: 1/4" X 2 1/4 Snapper Pin	
18	AFB-00018	Bolt: 1" X 3" Hex Cap	
19	A123357	Blade: Router Bit	
20	AFN-00012	Nut: Hex	
21	A123330	Blade: Center Straight	
22	A123330-SER	Blade: Center Serrated (optional)	
23	A123332R	Blade: Right Corner	
24	A123332L	Blade: Left Corner	
25	PB8P-NC-088-0275	Plow Bolt: 7/8" X 2 3/4 Gr 8	
26	AFN-00019	Nut: 7/8"	
27	501897	Dirt Shield-Right	

**ASHLAND SCRAPERS**

**Front Section - 700039**

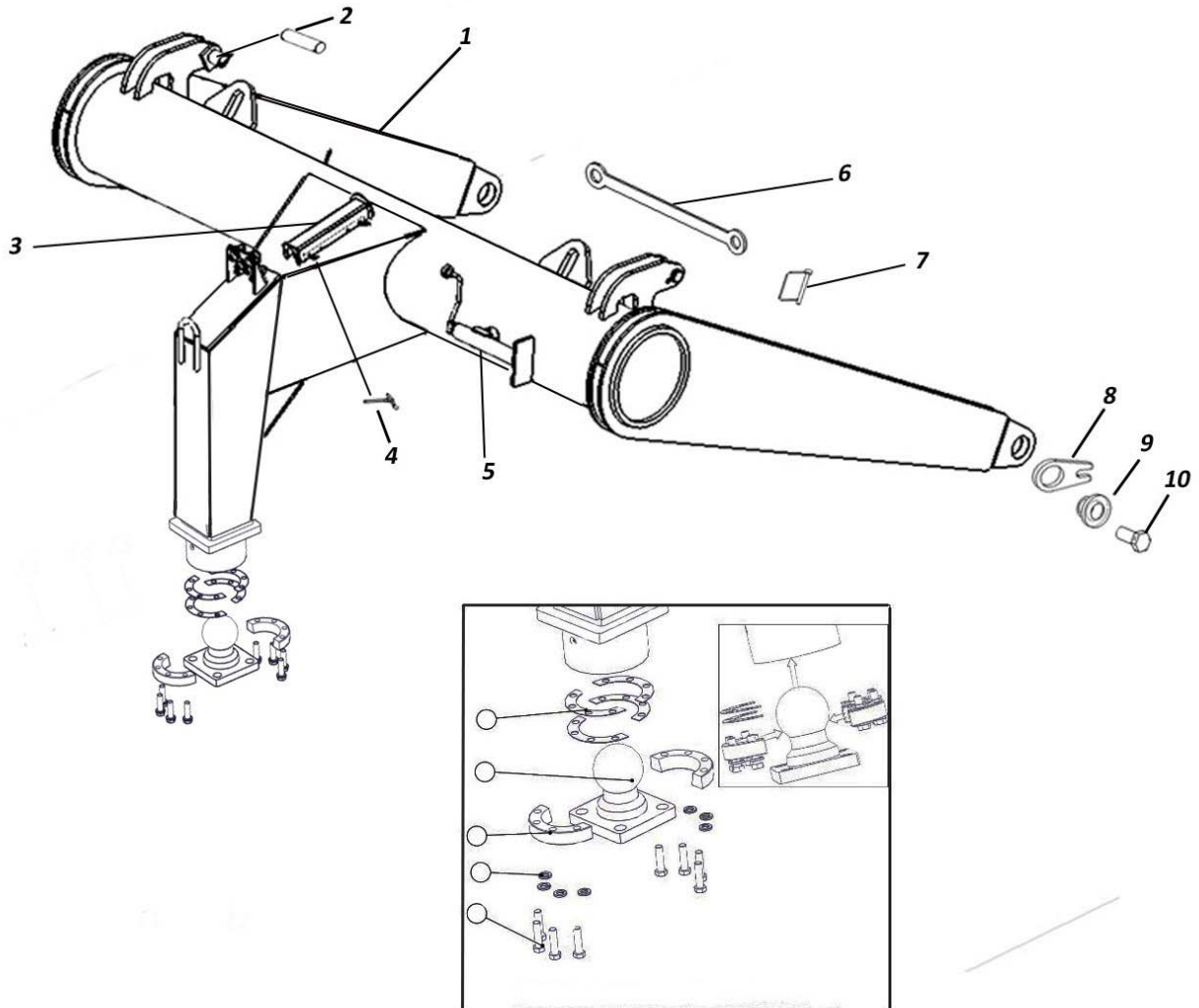

ITEM	PART	DESCRIPTION	SN 175XL2
1	700039	FRONT SECTION-GOOSENECK 175	24044-XXXXX
2	A123372	Pin: Lift Cylinder	
3	600100	Lock: Apron Cylinder	
4	A125261	Pin: Quick Rel. T Handle	
5	OPT-00001	Jack: Top Wind	
6	A123371	Transport Lock	
7	A125006	Pin: 1/4" X 2 1/2" Snap	
8	A123321-09	Pin: Main Frame	
9	A123358	Bushing: Pin Keeper	
10	AFB-00079	Bolt: 5/8"-11 X 11 1/2" Hex Cap	



**ASHLAND SCRAPERS**

**Front Section - Bracket (175)**

Standard Tire/Wheel Bracket

Big Tire/Wheel Bracket Option

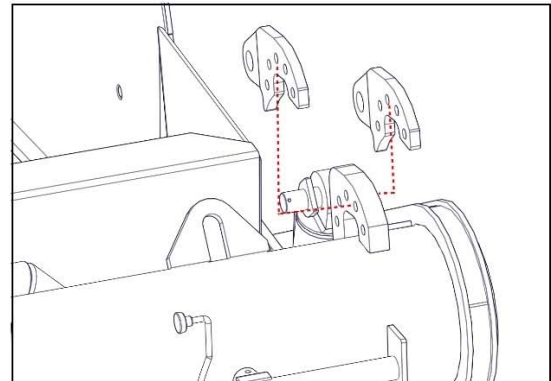
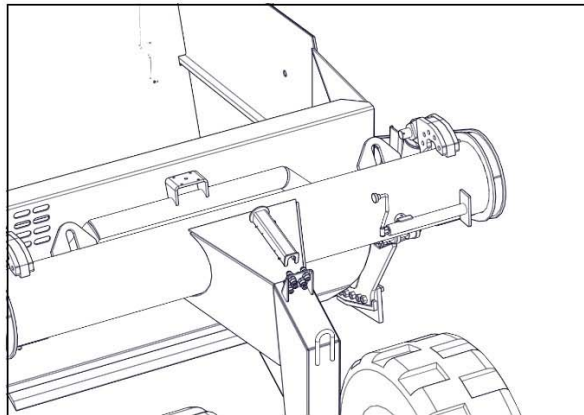
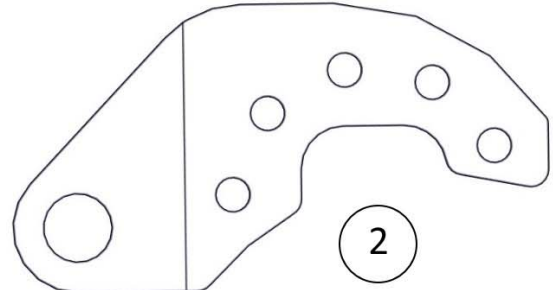
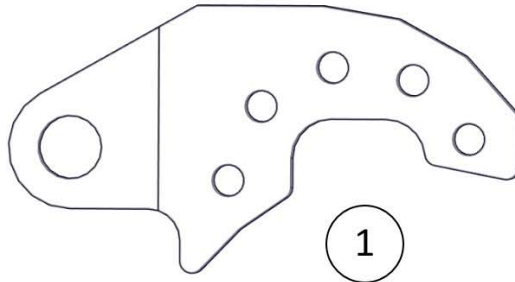

ITEM	PART	DESCRIPTION	SN 175XL2
1	503030	Ear: Lift Cylinder Mount, for 20.5 X 25 Tire	
2	503031	Ear: Lift Cylinder Mount, for 23.5 X 25 Tire (OPTIONAL)	
	AFB-00021	Bolt: 1" X 5 1/2" Gr 8 (Fastener)	
	AFN-00012	Nut: 1" Gr 8 (Fastener)	



**ASHLAND SCRAPERS**

**Pole - Axle - 700052**

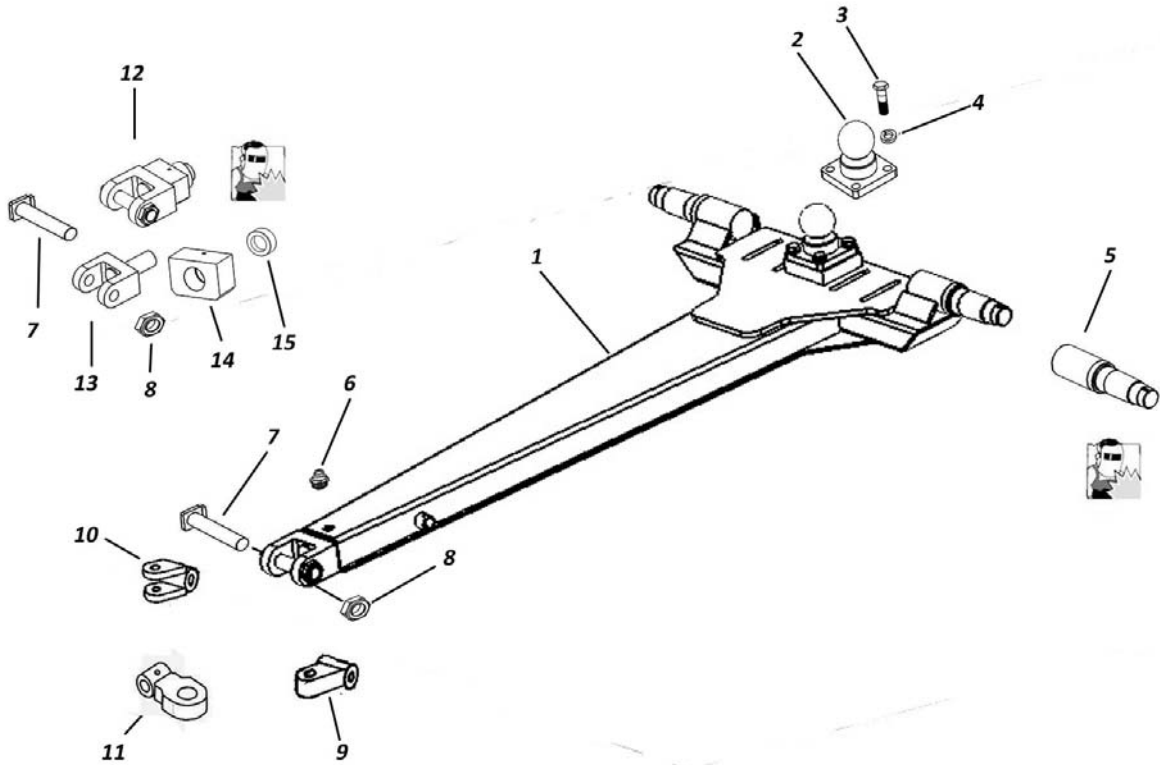

ITEM	PART	DESCRIPTION	SN 175XL2
1	700052	POLE AND AXLE ASSEMBLY 175	
2	601065	Ball Swivel	
3	AFB-00138	Bolt: 1"-8 X 4 1/2" Tap Bolt	
4	AFW-00006	Washer: 1"	
5	A14021	Spindle-Weld On	
6	14505	Grease Fitting	
7	600055	Pin: Swivel Hitch	
8	500462	Nut: Jam	
9	A17510	Swivel Hitch: Single	
10	A17511	Swivel Hitch: Double (option)	
11	A17512	Swivel Hitch: Cat 5 (option)	
12	600521	Swivel Hitch Assembly	
13	600522	Swivel Yoke	
14	501655	Swivel Block	
15	501654	Hitch: Retention Collar	

## Push-Off - 702018

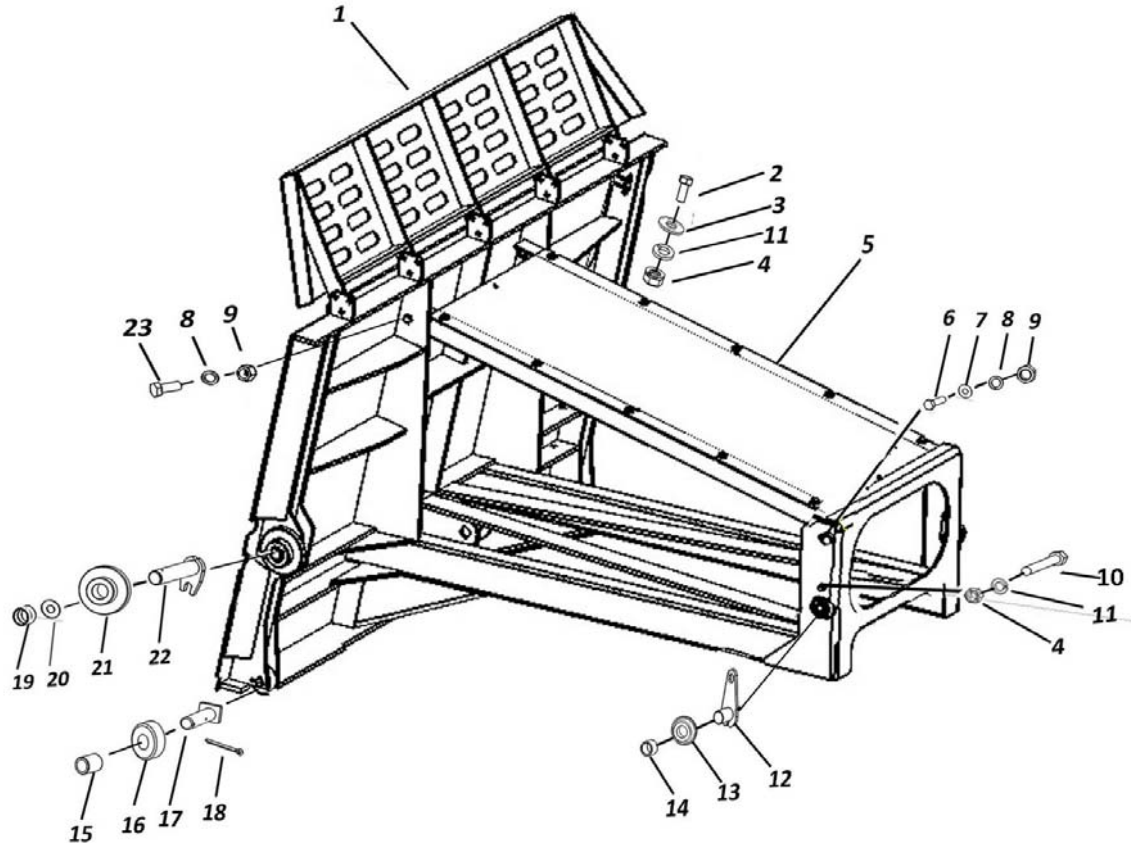

ITEM	PART	DESCRIPTION	SN 175XL2
1	702018	PUSHOFF - 175	
2	AFB-00015	Bolt: 1/2-13 X 1 1/2" Hex Cap	
3	AFW-00009	Washer: 1/2" Flat	
4	AFN-00011	Nut: 1/2" Hex	
5	500801	Dirt Shield: Pushoff	
6	AFB-00005	Bolt: 3/4-10 X 2 1/2" Hex	
7	AFW-00007	Washer: 3/4" Flat	
8	AFW-00002	Washer: 3/4" Lock	
9	AFN-00062	Nut: 3/4"	
10	AFB-00033	Bolt: 1/2"-13 X 2 1/2" Hex	
11	AFW-00030	Washer: 1/2" Lock	
12	A123305	Pin: 1 1/2 X 2 5/8" for Roller	
13	A123306	Roller: Pushoff	
14	A123307	Bushing: 1 1/4 ID X 1 5/8 OD X 1 1/2L	
15	A10163	Bushing: 1 1/4 X 1 3/4" X 2 3/8"	
16	A10164	Roller: Lower	
17	A123323-21	Pin: Lower Roller	
18	AFP-00001	Cotter Pin	

**ASHLAND SCRAPERS****Push-Off - 702018**

ITEM	PART	DESCRIPTION	SN 175XL2
19	A14039	Bushing: 2" ID X 2 3/8 OD X 2"	
20	501598	Shim	
21	502049	Roller: Hold Down	
22	A123323-23	Pin: Upper Roller	
23	AFB-00037	Bolt: 3/4"-10 X 2" Hex	

**ASHLAND SCRAPERS**

**Front Wheel (175)**

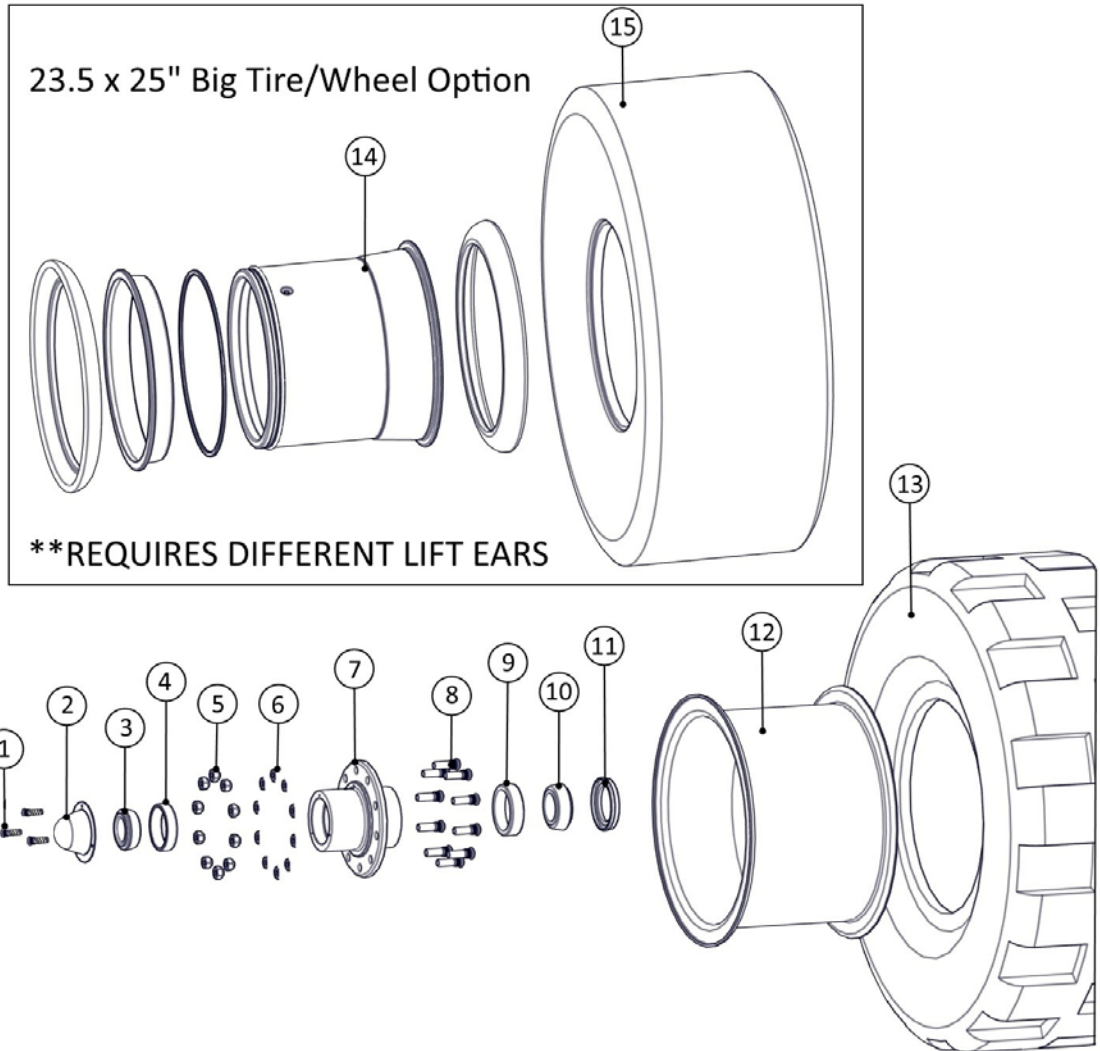

ITEM	PART	DESCRIPTION	SN 175XL2
1	AFB-00080	Bolt: 5/16" Gr 5	
2	A14004	Hub Cap: For A14010A Hub	
3	A14015	Bearing: Cone Outer	
4	A14014	Bearing: Cup Outer	
5	A14006	Nut: Lug 3/4"	
6	AFW-00036	Washer: Hardened	
7	A14010A	Hub: 10 Hole	
8	400257	Stud: Wheel 3/4" Gr 8	
9	A14013	Bearing: Cup Inner	
10	A14012	Bearing: Cone Inner	
11	A14011	Seal: Grease	
12	400229	Wheel: 17 X 25" 10 Hole Split Rim	
13	ATI-00010	Tire: 20.5 - 25" 16 Ply	
14	600403	Wheel Assy: 19.5 X 25" Thru Hole 5 Pc (OPTIONAL)	
15	ATI-00024	Tire: 23.5 - 25" 20 ply (OPTIONAL)	

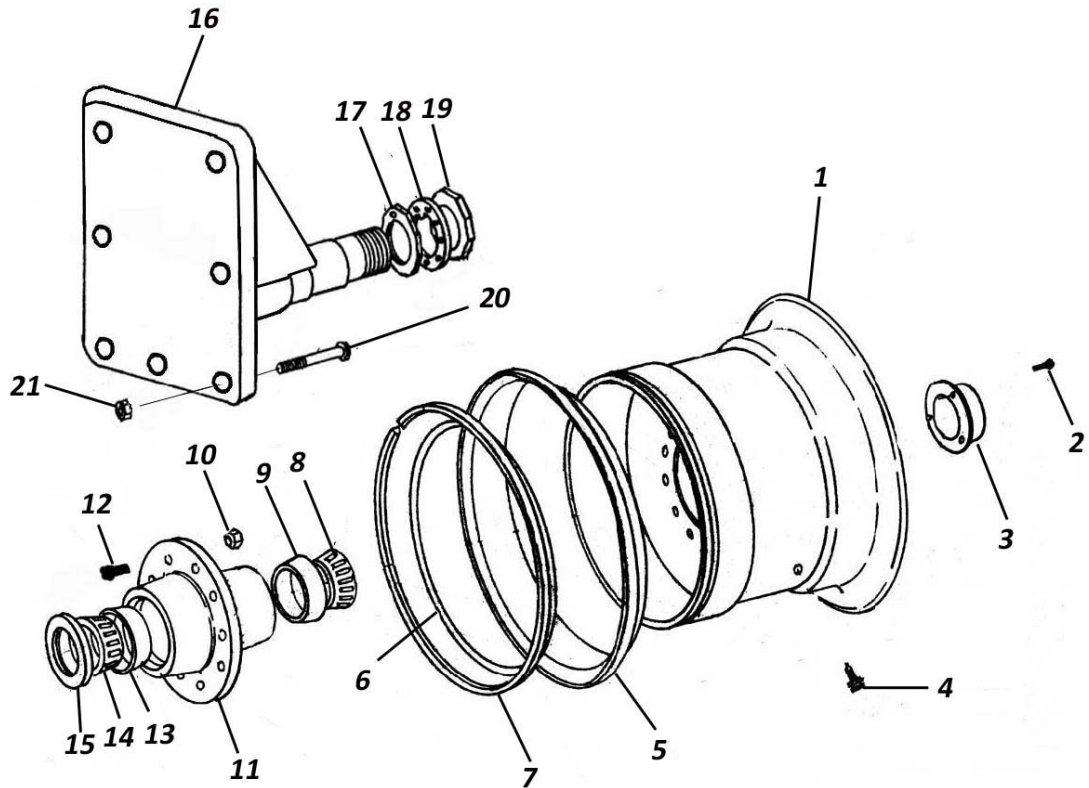
**ASHLAND SCRAPERS**
**Rear Wheel (155-175)**

ITEM	PART	DESCRIPTION	SN 175XL2
1	A12036	WHEEL 25" x 25"	
2	AFB-00080	Bolt 5/16" NC X 1/2" L	
3	A14004	Hub Cap	
4	A14016	Valve Stem	
5	A12041	Side Ring	
6	A12047	O-Ring	
7	A12042	Lock Ring	
8	A125001	Bearing Cone	
9	A125002	Bearing Cup	
10	A12051	Lug Nut	
11	A12035	Hub	
12	A12050	Lug	
13	A125004	Bearing Cup Inner	
14	A125003	Bearing Cone Inner	
15	A12037	Grease Seal	
16	A123350	Spindle	
17	A10172	Nut w/lock pin	
18	A10049A	Collar Spindle Lock Ring	
19	A10048	Spindle Nut	
20	AFB-00067	Bolt: 1 1/4" X 7 1/2"L	
21	AFN-00009	Nut: 1 1/4" Lock	

**ASHLAND SCRAPERS**

**Apron Cylinder - A125050**

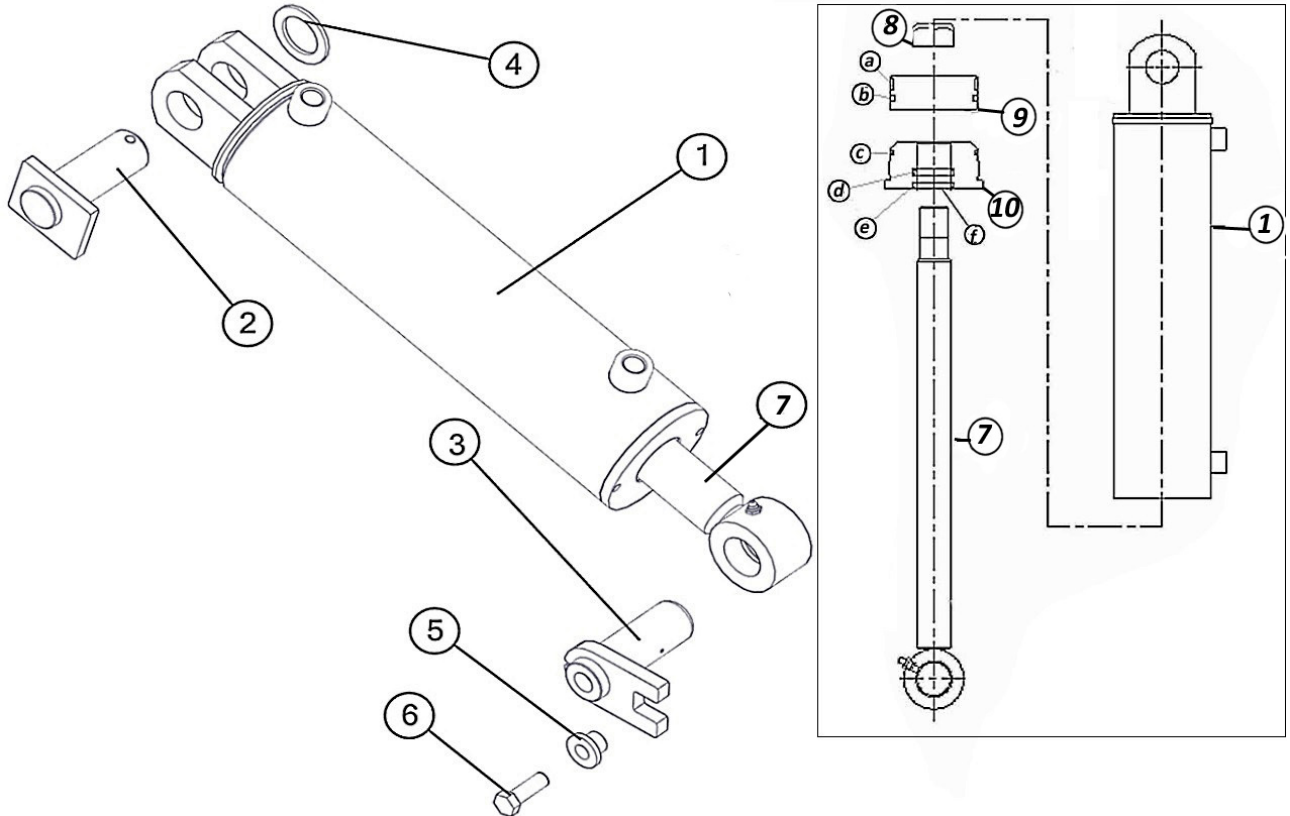

ITEM	PART	DESCRIPTION	SN 175XL2
		APRON CYLINDER (4 X 13")	
1	A125050-06	Barrel: for 4 X 13" Cyl.	
2	A123363	Pin: Apron Cylinder Base End, 1 1/2" X 4 1/8" (Greaseable)	
3	A123362	Pin: Apron Cylinder Rod End, 1 1/2" X 4 1/2"	
4	AFW-00016	Washer: 1 1/2" X 10 ga. NM bushing	
5	A123351	Bushing: Pin Keeper 9/16" X 3/4 X 3/4"	
6	AFB-00015	Bolt: 1/2" X 1 1/2" Gr 8	
7	A125050-01	Rod: Piston 1 3/4" dia w 1 1/2" Eye	
8	A125050-04	Nut: Lock 1 1/8" NF	
9	A125050-02	Piston: 4"	
10	A125050-03	Gland	
	A125050-05	Seal Kit Containing (a-f)	
a		Nylon Wear Ring	
b		FSP Seal	
c		O-Ring	
d		Backup Washer	
e		Hallite Rod Seal	
f		Snap in Rod Wiper	

**Lift Cylinder- (400226)**

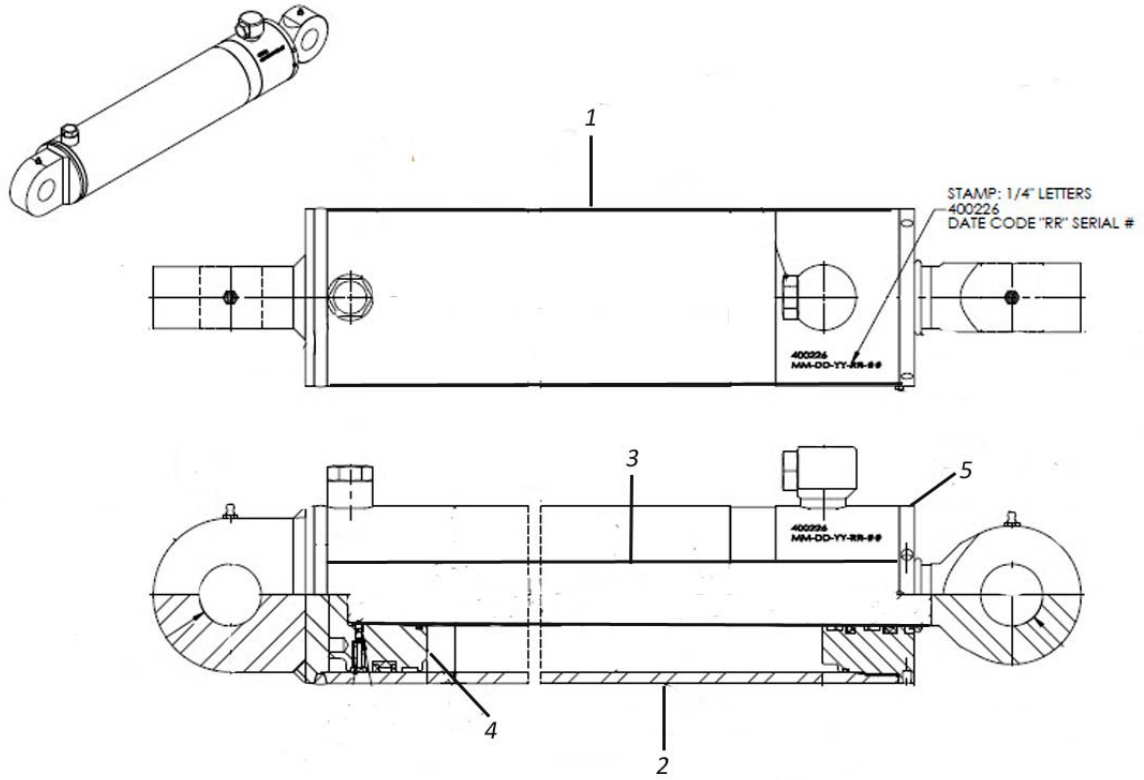

ITEM	PART	DESCRIPTION	SN 175XL2
1	400046	LIFT CYLINDER (5 x 20)	24030 and up + 23925
2	201881P	Barrel	
3	301549P	Rod	
4	400700P	Piston	
5	500855P	Head Gland	
	432026P	Seal Kit	



**ASHLAND SCRAPERS**

**Push-Off Cylinder - 400225**

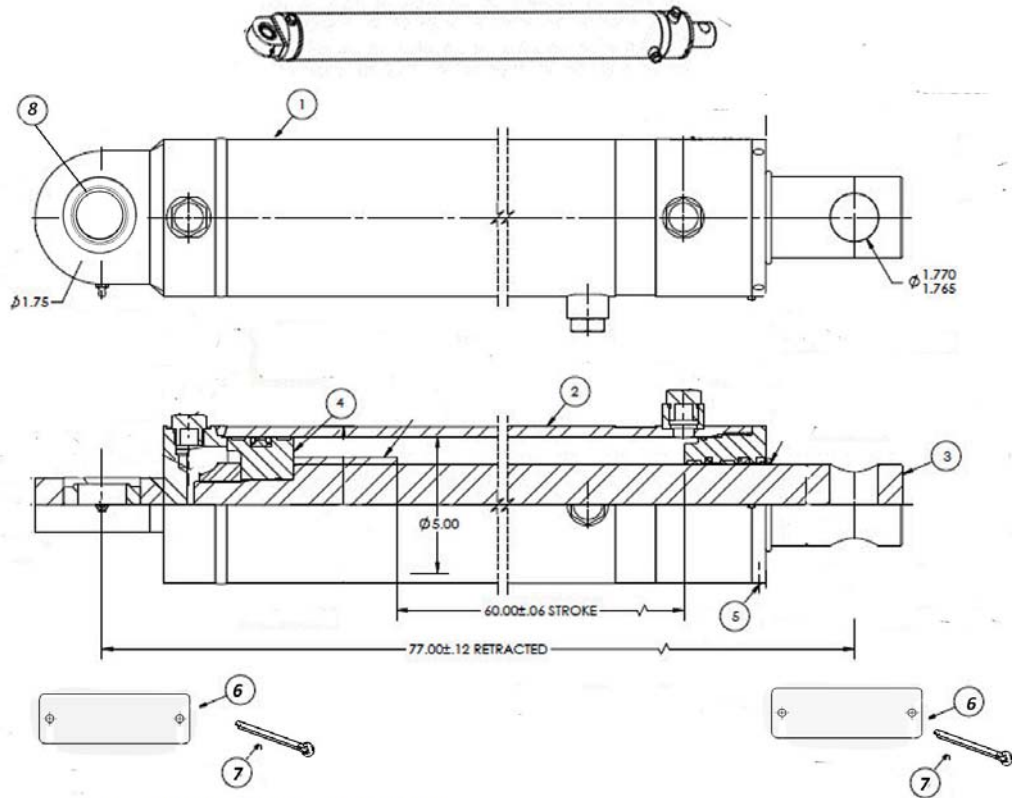

ASHLAND INDUSTRIES : CYL #400225  
PUSHOFF CYLINDER 5 X 60

ITEM	PART	DESCRIPTION	SN 175XL2
1	400225	PUSH-OFF CYLINDER (5 X 60")	24030 and up + 23925
2	201872P	Barrel	
3	301539P	Rod	
4	411079P	Piston	
	432007	Seal Kit	
5	511202P	Head Assy.	
	432008	Seal Kit	
6	501511	Pin	
7	AFP-00001	Cotter Pin	
8	720006P	Bushing	



**Decals (175XL-001)**

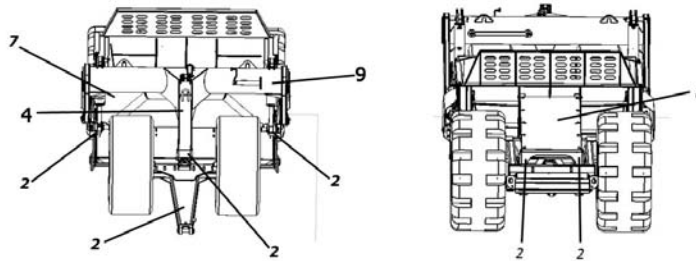
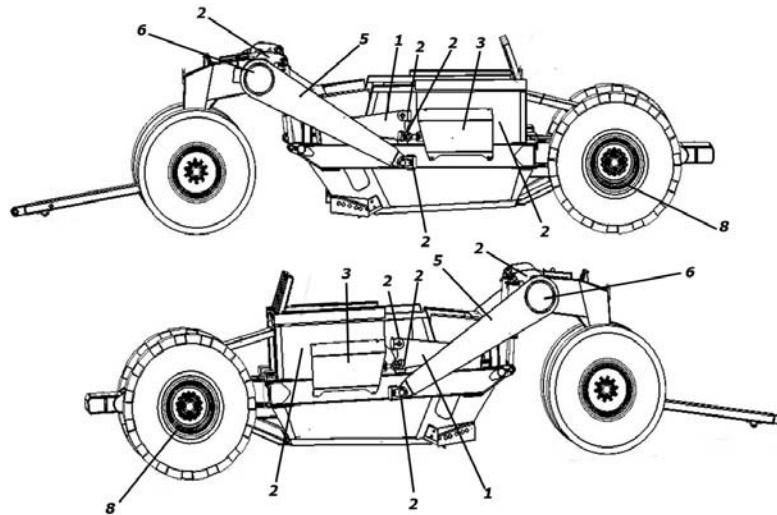

8

**IMPORTANT - SEE THE ILLUSTRATION**

Hub-pitched wheel used torque instructions:

1. Apply two drops of oil on the last 2 or 3 threads at the end of each stud before breaking on nut. Do not get lubricant on mounting face of flange or drop center.
2. Install nuts using installation sequence as shown below. Snug up nuts to about 50 ft.lbs. torque. DO NOT tighten fully until all nuts have been snugged.
3. Tighten all nuts to 450 to 500 ft.lbs. following tightening sequence listed below.
4. After running the scraper in a loaded operation, recheck torque level after first 2 hours, 40 hours and 100 hours. Retighten if necessary to 450 to 500 ft. lbs.



**Hydraulic Schematic**

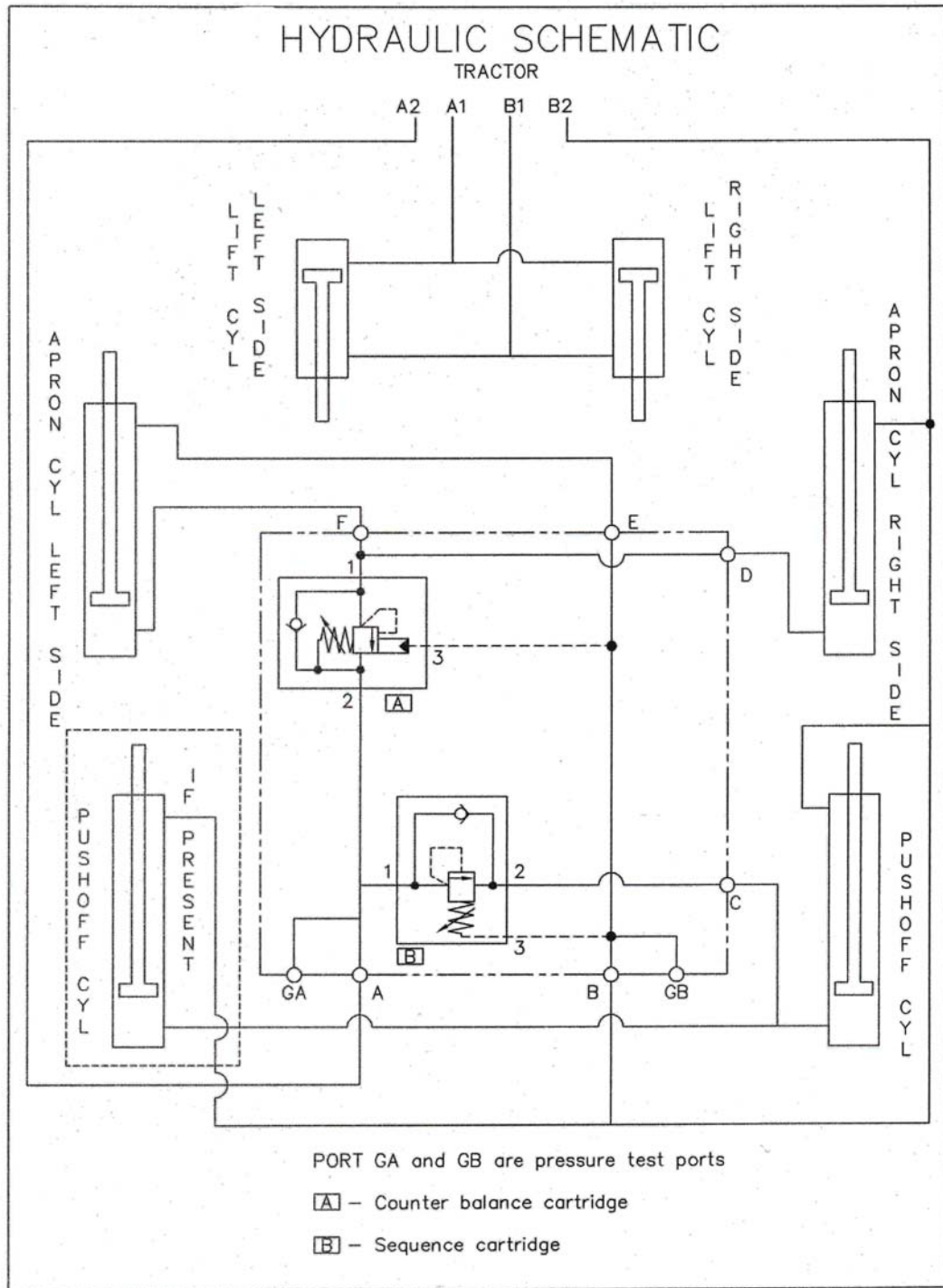

A400H003

**Hydraulic Manifold - A125174**



ITEM	PART	DESCRIPTION	SN 175XL2
1	A125162-02	PUSHOFF SEQUENCE CARTRIDGE	
2	A125162-01	COUNTER BALANCE CARTRIDGE	

**SETTING THE APRON AND PUSHOFF VALVE**

The manifold block containing the pushoff sequence valve cartridge and apron sequence valve cartridge is used to control two hydraulic circuits with one hydraulic remote. When the tractor hydraulic remote is activated, oil flows first to the apron cylinders until they are fully extended. Once the cylinders are fully extended, the apron circuits' hydraulic pressure begins to increase. Once the pressure threshold is surpassed (which is adjustable. See adjustment section), the sequence valve diverts the oil flow to the pushoff's hydraulic circuit. Once the push off is completely extended the operator then reverses the tractors hydraulic remote. The counterbalance valve will hold the apron open until the push off is fully retracted. The Apron sequence valve then opens and allows the apron to close.

**Setting the valves:**

**STEP 1 PUSHOFF SEQUENCE VALVE**

Loosen the lock nut (9/16") on the sequence valve cartridge. Turn the setscrew (4mm) clockwise until the front apron rises before the push-off begins to advance. (Earthmover should be empty) Turn the adjustment screw an additional 1/4 turn clockwise and tighten jam nut.

**STEP 2 COUNTER BALANCE VALVE**

Loosen the lock nut (9/16") on the counterbalance valve cartridge. Turn the setscrew (4mm) counter-clockwise until the apron holds in a raised position while rear gate is being retracted. Turn adjustment screw an additional 1/4 turn, tighten jam nut. DO NOT tighten adjusting screw more than necessary.

## Hydraulic Valve Ports

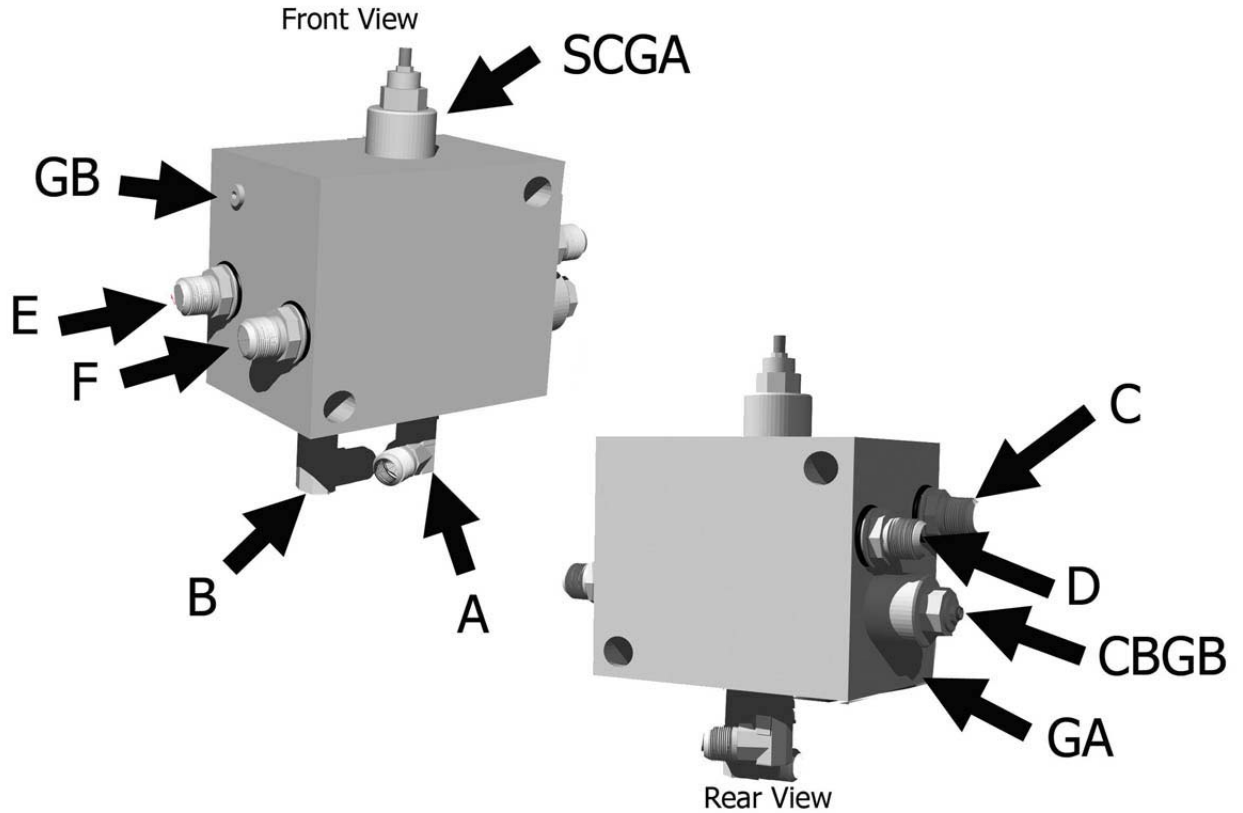

The lettering for the port locations are stamped on the block

A350P010

ITEM	PART	DESCRIPTION	SN 175XL2
A		Supply Line	
B		Pushoff Cyl., (Rod End)-Apron Cyl., Right side (Rod End)-Supply Line	
C		Pushoff Cylinder, (Base End)	
D		Apron Cylinder, Right side, (Base end)	
E		Apron Cylinder, Left side, (Rod end)	
F		Apron Cylinder, Left side, (Base end)	
CBGB		Counterbalance Valve, adjustable	
SCGA		Sequence Valve, adjustable	
GA		Pressure test port	
GB		Pressure test port	

## Hydraulic Valve Seals

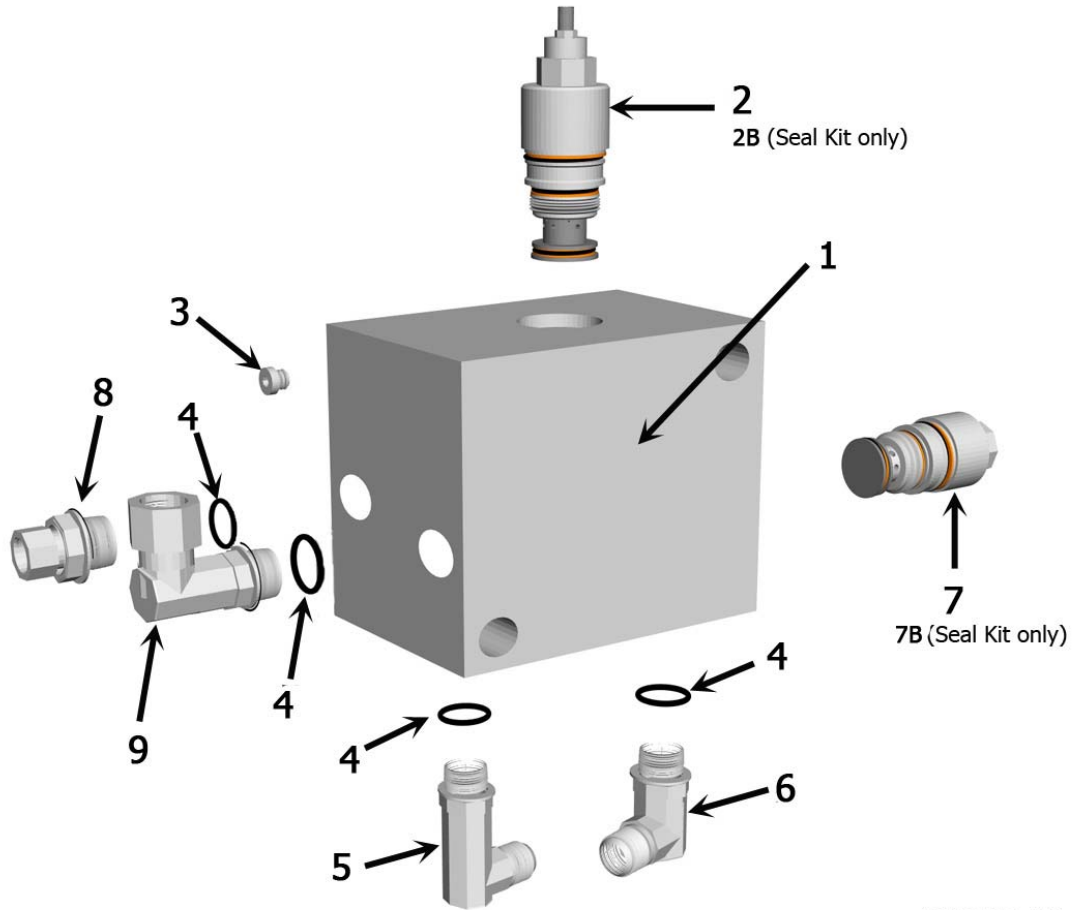

A350P005-9-175

ITEM	PART	DESCRIPTION	SN 175XL2
1	A125174	Valve: Manifold Block IV Body	
2	A125162-02	Valve: Sequence Cartridge for Ver. III & IV	
2b	A125162-02 KIT	Seal Kit for A125162-02 Valve Cartridge	
3	AHS-00046	6 ORB Plug	
4	AHS-00153	O-Ring for 12 M ORB Fitting	
5	AHA-00047	Adapter: 90 Dg. XL 3/4 MJX 1 1/6 M ORB	
6	AHA-00044	Adapter: 90 Deg. 3/4 MJ x 1 1/6 M ORB	
7	A125162-01	Valve: Counterbalance Cartridge for Ver. III X IV	
7b	A125162-01 KIT	Seal Kit for A125162-01 Valve Cartridge	
8	AHA-00043	Adapter: Str. Sw. 1 1/16 M ORB X 1/2 FP	
9	AHA-00048	Adapter: 90 Deg. Swiv. 1 1/6 M ORB X 1/2 FP	

**ASHLAND SCRAPERS**

**Hydraulic Plumbing Clamps**

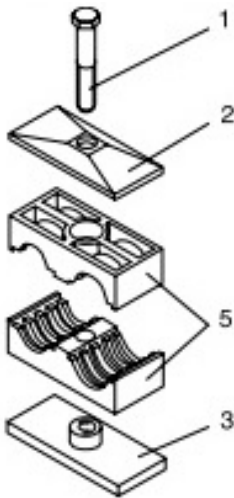

Twin Clamp with  
Weld Plate

AHL-00002

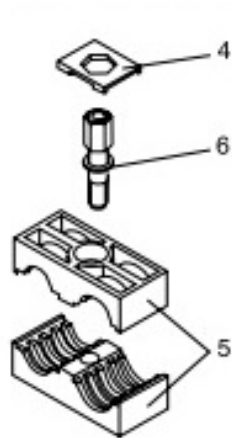

Twin Clamp  
Stacking Module

AHL-00022

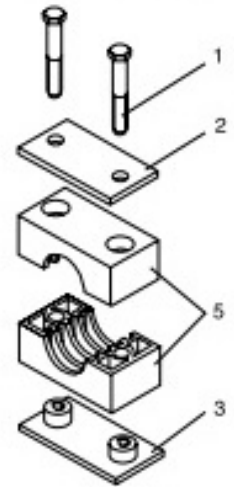

Single Clamp with  
Weld Plate

AHL-00001

Parts Legend	
1	Hex Head Bolt
2	Top Plate
3	Weld Plate
4	Safety Plate
5	Clamp Pair
6	Stacking Bolt



**ASHLAND SCRAPERS**

**Service: Grease Locations XL**

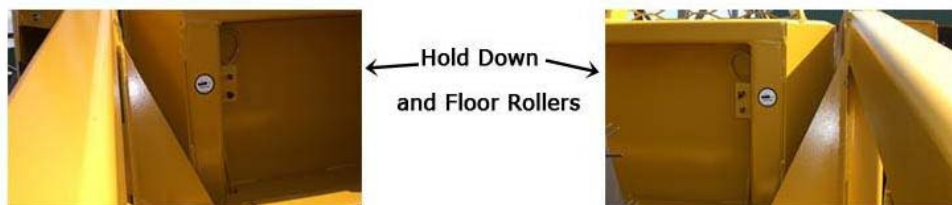
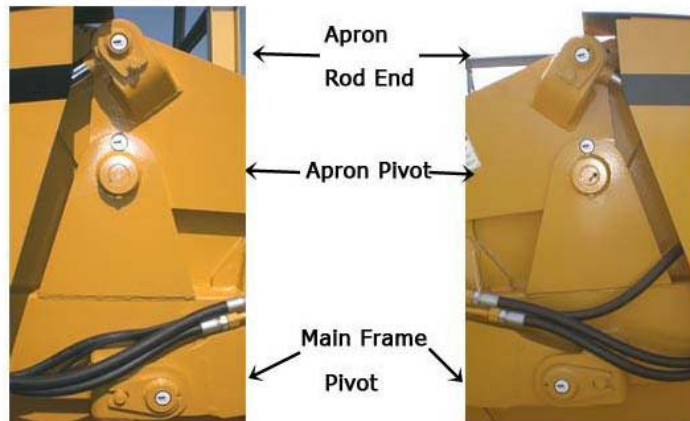
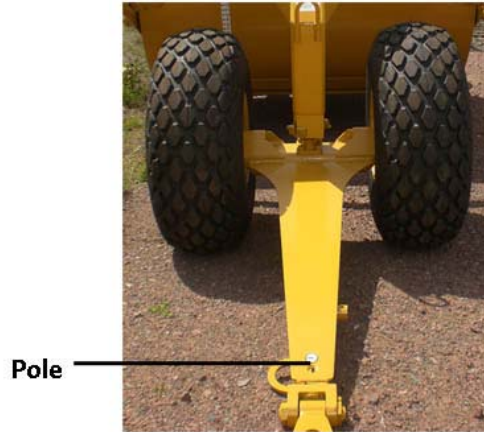

SN 175XL2

**ASHLAND SCRAPERS****Service: Grease Locations XL**

1. Hitch – Horizontal and vertical pins.
2. Lift Cylinders – Rod end & Base End; Both left & right sides.
3. Front Arm Pivot Joint – Both left & right sides.
4. Apron Cylinders – Rod clevis pin; Both left & right sides.
5. Apron Pivot Pin – Both left & right sides.
6. Hold-down Rollers – Both left & right sides.
7. Floor Rollers – Both left & right sides.
8. Tapered Rollers – Both left & right sides.



**ASHLAND SCRAPERS**
**Scraper Specifications 175XL2**

**I-175XL2 SPECIFICATIONS**

CAPACITY, STRUCK	14.1 cu yd
CAPACITY, HEAPED	17.5 cu yd
OVERALL DIMENSIONS: Length Width Height	30' in. 10' in. 7'11" in.
BUCKET: Width of Cut	62"
SHIPPING WEIGHT: (empty) Approx.	22,000 lbs.
CUTTING WIDTH:	108.5 in.
GROUND CLEARANCE:	16.5 in.
PAYLOAD WEIGHT (@2,250 lb./yd.)	43,750 yd <sup>3</sup>
BLADE: 5 pc. Center Corner Router	1 1/8 x 13 x 63 in. 7/8 x 8 x 22 in. 1 x 9 x 20 1/4 in.
CYLINDERS: Apron Lift Pushoff	Two (4 x 13) in. Two (5 x 20) in. Two (5 x 60) in.
HORSEPOWER REQUIREMENTS: Tractor	300-620 hp

**ASHLAND SCRAPERS**
**Tire Inflation**

SN 175XL2

**TIRE INFLATION & TORQUE CHARTS**

TIRE INFLATION (PSI)				
Scraper Model	Front Tire Size (XL)	Max PSI	Rear Tire Size	Max PSI
25			11L-15 8 Ply	35
50			16.5L-16.1 10 Ply	36
950	16.5L-16.1 10 Ply	36	16.9-24 8 Ply	35
140	550/45-22.5 16 Ply	41	18.4-26 18 ply	46
140 LGP	550/45-22.5 16 Ply	41	23.5-25 20 Ply	44
155	20.5-25 12 Ply	38	29.5-25 28 Ply	62
175	20.5-25 12 Ply	38	29.5-25 28 Ply	62
175 (Big Tire)	23.5-25 20 Ply	44	29.5-25 28 Ply	62
215			20.5-25 20 Ply	65
220			20.5-25 20 Ply	65
2014			20.5-25 20 Ply	65

**On new machines, the wheels should be retorqued after the first two hours of use.** Then check tires daily to ensure correct inflation levels. Check tire pressure with an accurate gauge having 6.9 kPa (0.07 bar) 1 psi gradations. Check tires daily to ensure correct inflation levels. Also check for:

- Tire Damage
- Loose or missing wheel lugs, nuts or caps
- Uneven wear
- Damaged Rims

**Standard Torque Chart:**

Torque Ft-lbs	Bolt Diameter
12	1/4"
25	5/16"
45	3/8"
70	7/16"
110	1/2"
150	9/16"
220	5/8"
380	3/4"
600	7/8"

**ASHLAND SCRAPERS****Maintenance Check List**

1. Grease all zerks.
  - a) Every 8 hours of operation.
  - b) See Lubrication Points section on next page.
  
2. Greasing the hubs.
  - a) Re-pack wheel bearings after 300 hrs of operation.
  - b) Completely clean grease out of hub and bearings every 1200 hours of operation.
  
3. Check tire pressure.
  - a) See Tire Pressure Chart.
  
4. Check all pins for signs of wear.
  - a) Daily
  
5. Check wheel lug nut torque.
  - a) After first 2 hours of operation.
  - b) Recheck daily for next 2 weeks.
  - c) Tighten wheel lug nuts in a star pattern.
  - d) Torque wheel lug nuts (See Torque Specifications).
  
6. Check and retighten all bolts.
  - a) After initial 10 hours of use.
  - b) Again after 50 hours of use.
  - c) See Torque Specifications.
  
7. Inspect cutting edges.
  - a) Daily
  - b) Replace cutting edges when center blade has been worn to approximately 6" and side edges worn to approximately 4".



**CAUTION!** Failure to replace worn cutting edges may result in unnecessary wear to the earthmover sides and floor.

Note: Please specify left or right "L" shaped cutting edges when ordering replacements. Left or right side parts are determined by viewing from rear of the scraper.

**ASHLAND SCRAPERS****Service: Tire Service**

**The task of servicing tires and wheels can be extremely dangerous and should be performed by trained personnel only, using the correct tools and following specific procedures. Do not attempt to mount, demount or inflate a tire if you do not have the proper equipment and experience to perform the job. Call a qualified repair service to inspect the assembly and make necessary repairs. Failure to heed warnings could lead to serious injury or death.**

Visually inspect tires and wheels daily. Carefully inspect any rim and tire assembly that has been run underinflated or flat before reinflating the tire to make sure there is no damage to either the rim or tire.

- ALWAYS wear personal protection equipment such as gloves, footwear, eye protection, hearing protection and head gear when servicing tire and wheel components.
- DO NOT operate with damaged rims, tire cuts or bubbles, missing lug bolts or nuts or damaged rims.
- ALWAYS maintain the correct tire pressure. NEVER exceed recommended tire inflation pressure.
- INSPECT any rim and tire assembly that has been run flat or severely underinflated before reinflating the tire. Damage to the rim and tire may have developed.
- NEVER inflate a tire that has lost air pressure or has been run flat without determining and correcting the problem.
- NEVER try to repair wheel, rim, or tire components parts. Parts that are cracked, worn, pitted with corrosion, or damaged must be discarded, and replaced with good parts.
- ALWAYS use approved tire and rim combinations for the model scraper that you have and verify that part numbers of components are correctly matched for the assembly.
- ALWAYS exhaust all air from the tire prior to demounting.
- ALWAYS place wheel and tire assemblies in restraining devices (safety cage) when inflating tires. Use a clip-on chuck and long extension hose to allow you to stand to the side of the tire and not in front of it.
- NEVER weld or cut on an inflated tire assembly. Welding heat can cause increased pressure which could result in tire explosion.
- ALWAYS use proper lifting techniques, and mechanized lifting aids to move heavy components and assemblies.
- NEVER leave a tire, wheel, or assembly unsecured in a vertical position.
- ALWAYS take care when moving tires and wheels that other people in the area are not endangered.

**ASHLAND SCRAPERS****Troubleshooting**

With proper care and maintenance, your Ashland Scraper will give many years of reliable service. When a situation arises where the earthmover performance is not satisfactory, this section will give some pointers on finding and correcting the problem.

---

**Grease zerk will not take grease.**

---

1. Grease zerk plugged.
  - a) Remove and replace grease zerk.
2. Pin is frozen.
  - a) Remove, clean, and inspect pin.
  - b) Replace pin if necessary.
3. Bushing grease passage is not aligned with grease zerk.
  - a) Remove, clean, inspect, and realign bushing.
  - b) Replace bushing if necessary and realign.

---

**Push-off rollers do not roll.**

---

1. The rollers need lubrication.
  - a) Check zerk hole and grease.
  - b) Remove pin, clean, inspect, and replace if necessary.
2. The roller bushing is worn out.
  - a) Remove roller assembly and replace bushing.
  - b) See parts manual.

---

**Cylinders will not hold in preset position, i.e. the cylinder creeps.**

---

1. Seals leaking internally.
  - a) Remove and replace seal kit.

---

**Machine cuts unevenly.**

---

1. Cutting edges worn unevenly.
  - a) Replace cutting edges.
2. Improperly inflated tires.
  - a) Check air pressure in tires.

**ASHLAND SCRAPERS****Warranty Statement****The Purpose of Warranty**

Ashland Industries warrants each new product to be free from defects in material and workmanship. This warranty is applicable only for the normal service life expectancy of the product or components, not to exceed one year from the date of delivery of the new Ashland Industries product to the original purchaser, or the date the product is first put into service via a rental agreement or other means, whichever occurs first.

**Dealer Responsibilities**

The following responsibilities are to be performed when the dealer delivers a product to the purchaser or otherwise places it into warranty service:

Complete the Warranty Registration Form and forward it to Ashland Industries within 30 days of the sale, rental or other use of the product. Warranty reimbursement is contingent upon product registration.

Review the warranty statement and operator's manual with purchaser to assure understanding of purchaser's responsibilities as related to warranty, service, and the proper and safe operation of the product. Purchasers/Renters should be advised to have failed parts repaired or replaced immediately upon failure, as continued use will result in additional damage, excessive wear, and may result in personal injury.

Contact Ashland Industries prior to beginning repair or replacement of failed parts to make certain that the cost of repairs are consistent with the value of the product being sold.

Warranty requests for units in dealer's inventory may be submitted to Ashland Industries when defects are noted in products prior to the retail sale or rental of that unit.

Provide warranty and service repairs as directed by Ashland Industries' "Service Repairs Bulletins" or other instructions.

All warranty work must be completed within 30 days of failure. Notify Ashland Industries' warranty department if repairs will require more than 30 days after failure for an extension. No claim will be accepted for warranties that exceed this 30 day period.

No warranty will be allowed on units delivered to the retail customer prior to the full payment of that unit to the manufacturer by the dealer.

If diagnostic time is required, contact Ashland Industries Inc. prior to beginning the warranty repair for approval. Ashland Industries must approve travel time reimbursement prior to beginning the warranty repair.

**Ashland Industries Responsibilities**

Reimbursement for parts used in warranty repair will be credited only when the parts are purchased from Ashland Industries Inc. Parts will be credited at dealer's net cost. No warranty will be allowed on parts that are past due.

Dealer should use parts from their parts inventory first. In the event that parts must be shipped from Ashland Industries Inc., freight will be paid by Ashland Industries and will be shipped by the most economical means to arrive in the shortest possible time. Air, Next Day Air, Priority and other special shipment methods requested by the dealer will be at the customer's expense.

Warranty Labor Reimbursement for labor expense to the dealer is made by payment of the established hourly shop rate.

Repair times will be reviewed by Ashland Industries Inc. and may be adjusted to average repair time required by other dealers to make similar repairs. Labor is not paid on the warranty associated with repair parts purchased by the retail customer that are used on a product that is not currently in warranty time frame.

Reimbursements for repairs made by an outside source (not dealer personnel) will be made for those services deemed necessary for the resolution of the warranty by Ashland Industries' warranty department.

Outside repair invoices must have prior approval from Ashland Industries' service department and must be attached to the warranty claim after approval.

**ASHLAND SCRAPERS****Warranty Statement****Other Warranty Provisions**

The following guidelines are to be followed when performing warranty repairs:

In all cases, the most economical repair should be performed unless otherwise directed. Credit will not be allowed for assemblies or groups if it is practical to make the repair with individual parts. In some cases, the assembly or group price may be less than the total of the parts and labor required to complete the repair. In those cases, an assembly or group may be used.

Only those parts provided by Ashland Industries are covered under Warranty. The use of parts from other sources will not be eligible for warranty consideration.

All parts removed during warranty repair should be held for a period of 90 days after the warranty claim has been submitted to Ashland Industries Inc. These parts can be discarded if disposition or return request hasn't been made during this period. Parts that are requested must be returned within 30 days of claim disposition. These parts will be discarded after the 30 day period.

Ashland Industries Inc. reserves the right to deny or reverse any and all warranty claims for parts, labor or miscellaneous charges when errors are found, warranty provisions are abused, or fraudulent claims are submitted.

**Warranty Reimbursement is Not Possible**

When failure falls under the "limitations" as identified in Ashland's Limited Warranty Statement.

When Ashland Industries has requested the return of certain parts, assemblies or information and has not received the material with 30 days of date posted on return request.

On claims due to damage or shortage that are obviously the responsibility of dealer or the delivering carrier.

On the entire claim when warranty policy and provisions are not followed.

*All dealers will warranty their technician's work to the purchaser and will indemnify Ashland Industries Inc. from such claims.*

**Service Bulletins**

Service Bulletins will be issued when necessary to alert dealers of special repairs. Each bulletin will give detailed directions and procedures to complete the service.

**Procedures For Completion Of Warranty Form**

Complete the warranty form available at [www.ashlandind.com](http://www.ashlandind.com) or in your dealer's yellow Ashland Sales Book. Return this form to Ashland Industries within 30 days of failure.

**Use of Photos**

Pictures of the failure are recommended but not required. Photos should be attached to dealer's claim when their inclusion will help identify the condition of the part being repaired or replaced, and thus assisting in approval of the claim. In many cases, the use of photos may eliminate the need to return parts for evaluation. Photos will not be returned unless specifically requested. Digital photography will also be acceptable and can either be mailed or email to [warranty@ashlandind.com](mailto:warranty@ashlandind.com)

**Delayed Warranty Repairs**

Warranty repairs should be scheduled and performed as soon as possible after notifying dealer and Ashland Industries. There may be circumstances that require the use of the product for a short period of time by the retail customer, or the availability of repair parts may require the work to extend past a 30 day period. In these cases, the dealer must notify Ashland Industries in writing of the extenuating circumstance and advise that the continued use of the product will not enlarge the warranty claim. These claims will then be processed as if the product is still within the warranty period.

**Denied Claim**

Dealers will be notified of a denied claim in writing, and notification will state the reason for denial. A dealer has the right to appeal this claim and must do so within 30 days of notification of denial. If there has been no appeal within the 30 day period, the claim will be considered closed.

## ASHLAND SCRAPERS

# Warranty Statement

### Limited Warranty Statement

Ashland Industries Inc. warrants each new product to be free from defects in material and workmanship. This warranty is applicable for products or components, not to exceed one year from the date of delivery of the new Ashland Industries product to the original purchaser, or the date the product is first put into service via a rental agreement or other means, whichever occurs first.

The major components of swivel hitches used on Industrial series scrapers are warranted for three consecutive months from the date of delivery of the new Ashland Industries product to the purchaser, or the date the product is first put into service via a rental agreement or other means, whichever occurs first, except those components described below.

Genuine Ashland Industries Inc. replacement parts and components will be warranted for 30 days from date of purchase, or the remainder of the original equipment warranty period, whichever is longer.

Under no circumstances will it cover any merchandise or components thereof, which in the opinion of the company, has been subjected to misuse, unauthorized modification, alterations, an accident or if repairs have been made with parts other than those obtained through Ashland Industries Inc.

Ashland Industries Inc. in no way warrants tires since their respective manufacturer warrants these items separately. Please call Ashland Industries Inc. to receive phone numbers of tire suppliers.

Ashland Industries Inc. in no way warrants wearable items such as cutting edges, front dolly wheel balls, socket halves, rollers, bushings, yoke hitch pins, hitch bushings, etc.

Our obligation under this warranty shall be limited to repairing or replacing, free of charge to the original purchaser, any part that, in our judgement, shall show evidence of such defect, provided further that such part shall be returned within 30 days from the date of failure to Ashland Industries Inc. routed through the dealer and distributor from whom the purchase was made, transportation charges prepaid. Upon warranty approval proper credits will be reimbursed for transportation.

This warranty shall not be interpreted to render Ashland Industries Inc. liable for injury or damages of any kind or nature to person or property. This warranty does not extend to the loss revenue, extra labor cost associated with downtime, substitute machinery, rental or for any other reason.

Except as set forth above, Ashland Industries Inc. Shall have no obligation or liability of any kind on account of any of its equipment and shall not be liable for special or consequential damages. Ashland Industries Inc. make no other warranty, expressed or implied, and, specifically, Ashland Industries Inc. disclaims any implied warrant or merchantability or fitness for a particular purpose. Some states or provinces do not permit limitations or exclusions of implied warranties or incidental or consequential damages, so the limitations or exclusion in this warranty may not apply.

This warranty is subject to any existing conditions of supply which may directly affect our ability to obtain materials or manufacture replacement parts.

Ashland Industries Inc. reserves the right to make improvements in design or changes in specifications at any time, without incurring any obligation to owners of units previously sold. No one is authorized to alter, modify or enlarge this warranty nor the exclusion, limitations and reservations.

### Owner Registration

Be sure to complete the Owner Registration form that you received with your machine and return it to Ashland Industries within 30 days of the sale, rental or other use of your product. Warranty reimbursement is contingent upon product registration. If your product is not registered, it is NOT covered under warranty.