

ASHLAND INDUSTRIES

Parts Manual ***I-950***

12-15



Ashland Industries

Crafting Quality since 1953!



1115 Rail Drive
P.O. Box 717
Ashland, WI U.S.A.
Toll Free: (877) 634-4622
Business: (715) 682-4622
Fax: (715) 682-9717

www.ashlandind.com
www.scaperdrawbar.com

Table of Contents

Categorized Listing

ASHLAND SCRAPERS	1
Introduction	1
Operators and Maintenance	2
Safety Guidelines	5
XL Assembly	6
Gooseneck Frame Assembly (900-950)	7
Apron Assembly (950)	8
Bowl & Frame Assembly (900-950)	9
Push Off Assembly (900-950)	11
Pole & Axle Assembly (900-950)	13
Wheel Assembly (900-950)	15
Lift Cylinder (#A416H118) 4" X 16"	16
Apron Cylinder (#A125050) 4" X 13"	18
Parts - Cylinder - Push Off (400060) 4" x 50"	19
Hydraulic Manifold (#A125174)	20
Hydraulic Valve Ports Assembly	21
Hydraulic Valve Seals	22
Hydraulic Plumbing Front (I-950)	23
Hydraulic Plumbing Rear (I-950)	24
Parts - Hydraulic Clamps	25
Hydraulic Hoses (I-950))	26
Decals Illustration (I-950)	27
Decals	28
Maintenance Check list	29
Lubrication Points	30
Torque Specifications	31
Tire Service	32
Tire Inflation & Torque Charts	33
Pushing the Earthmover	34
Troubleshooting	35
Warranty Statement	36

Table of Contents

Alphabetized Listing

A	
Apron Assembly (950)	8
Apron Cylinder (#A125050) 4" X 13"	18
ASHLAND SCRAPERS	1-36
B	
Bowl & Frame Assembly (900-950)	9
D	
Decals	28
Decals Illustration (I-950)	27
G	
Gooseneck Frame Assembly	7
H	
Hydraulic Hoses (I-950)	26
Hydraulic Manifold (#A125174)	20
Hydraulic Plumbing Front (I-950)	23
Hydraulic Plumbing Rear (I-950)	24
Hydraulic Valve Ports Assembly	21
Hydraulic Valve Seals	22
I	
Introduction	1
L	
Lift Cylinder (#A416H118) 4" X 16"	16
Lubrication Points	30
M	
Maintenance Check list	29
O	
Operators and Maintenance	2
P	
Parts - Cylinder - Push Off	19
Parts - Hydraulic Clamps	25
Pole & Axle Assembly (900-950)	13
Push Off Assembly (900-950)	11
Pushing the Earthmover	34
S	
Safety Guidelines	5
T	
Tire Inflation & Torque Charts	33
Tire Service	32
Torque Specifications	31
Troubleshooting	35
W	
Warranty Statement	36
Wheel Assembly (900-950)	15
X	
XL Assembly	6

Introduction

Thank you for choosing an Ashland scraper for your earthmoving needs. Years of research, testing and successful application have been spent to ensure quality and maximum performance for our customers.

QUALITY POLICY

It is our mission to exceed our customers' expectations in quality, delivery, and cost through continuous improvement and customer interaction.

Please read and understand this manual before attempting to attach or operate this scraper. This manual should always remain with the machine. Be sure and fill out and send in the owners registration form at the beginning of this manual, or you may fill out the form on-line by going to ashlandind.com and click on "Register your Machine" at the bottom of the page. If you have questions, please feel free to call or email us. You can visit us on-line at www.ashlandind.com.

Ashland Industries hours of operation are 8:00 a.m. to 5:00 p.m. CST. We can be reached toll free at: 877-634-4622.

SCRAPER ID NUMBER

The serial number plate for the scraper is located on the right rear area of the scraper. The letter and numbers stamped identify the serial number, model number and capacity of the scraper. Please record this serial number for use in ordering parts, warrantee issues and to track your equipment it is ever stolen.

References to serial number breaks on parts are located in the manual with a reference sequence of XXXXX-XXXXX. The beginning number records the serial number start of the use of that part. The ending number is the final serial number use of the part within this machine.



IMPORTANT

Parts must be ordered through your local authorized ASHLAND dealer. Be sure to state MODEL and SERIAL NUMBER of your machine. Ashland Industries weldable replacement parts are also available to rebuild, modify or update your scraper to current factory specifications.

ASHLAND SCRAPERS**Operators and Maintenance**

Your Ashland scraper is a durable piece of equipment and with proper care will yield many years of trouble free operation. However, the life of your scraper can be severely shortened by poor maintenance. You must follow consistent maintenance practices and use good quality grease and hydraulic oil (compatible with the power unit's hydraulic system) to insure the longer, most productive use from your scraper.

Your scraper should be greased at all points where grease fittings are provided. **REMOVE TRANSPORT LOCKS** prior to operation. Next, extend and retract all cylinders several times to force out any air from the hydraulic cylinders and lines. Check the oil levels in the tractor hydraulic system and add to maintain the proper level. Care should be used when adding oil or when disconnecting any oil line to keep all dirt out of the oil as dirt is a major factor in the failure of hydraulic components.

When your scraper is placed into operation, the operator will have to "feel out" the amount of depth of cut to obtain maximum loading efficiency. This is usually accomplished by taking a lesser and more uniform cut; however, some soil conditions such as loose sand may require a "pumping action" obtained by taking successive deep cuts and lifting out of cut as the tractor begins to lose power or traction.

- After 8 hours of operation, all bolts should be checked and tightened if necessary and all grease fittings lubricated. Check tire pressures daily. Also, check pins and cutting edges for signs of wear.
- After 50 hours work, all bolts should be rechecked and tightened if necessary. Check wheel bearings and adjust if necessary.
- Check wheel lug nut torque.
 - After first 2 hours of operation.
 - Recheck daily for the next 2 weeks.
 - Tighten wheel lug nuts in a star pattern.
 - Torque wheel lug nut (see Torque Specifications).
- After 300 hours work, clean and repack wheel bearings and replace, if necessary, cutting edges, worn pins, etc.



Failure to replace worn cutting edges may result in unnecessary wear to the earthmover sides and floor.

ASHLAND SCRAPERS**Operators and Maintenance**

Before starting a job, make sure Diggers Hot Line has been contacted and all underground utilities have been properly located (electric, phone and pipelines). Have a clear understanding of all local, OSHA and MSHA rules that apply to the job. Beware of your environment and keep others a safe distance from the machine while familiarizing yourself with the machine's controls. The scraper requires a power source with **TWO** 4-way (double acting) hydraulic control valves.

**Scraper damage can occur if:**

1. The scraper is running over the haul road with the bowl fully raised.
2. A power unit that is above the horsepower rating is pulling the scraper.
3. The scraper is being used to level haul roads with the apron closed.
4. The scraper is being top loaded with the bowl is a raised position.
5. The scraper is being used to load rock.

These types of damage are not covered by warranty. Warranty only covers defects in material or workmanship and not abuse because of improper use.

Know the job:

1. Know the weight of the material to be moved.
2. Lay the job out to take advantage of grades when loading, if possible.
3. Keep hauls as short as possible.
4. Keep haul roads smooth.
5. If more than one unit is on the job, make sure the haul roads are one way and that the operators understand the direction.
6. Brief the operators as to what the job consists of so there is not misunderstanding.
7. Know the moisture content in the material to be moved.
8. Will water be needed for proper compaction?
9. Will drainage be a problem?
10. How many units will be needed to efficiently complete the job?

Transport the scraper safely:

1. Always empty scraper.
2. Clean all material from exterior of scraper.
3. Make sure all road rules are followed.
4. Use proper lighting and flagging.
5. Lower scraper bowls to provide just enough clearance over obstacles.
6. Transport at a safe speed to avoid roll over.
7. Reduce speed on curves and when going downhill.

Operators and Maintenance

Apron Opening Guidelines:

You will need to determine the ideal opening for your soil condition. It is important to have the apron opened prior to loading. To receive the highest production possible, it is important to know the general characteristics of the material that you will be loading. In heavier soils like clay or gumbo, the soil will slab up and remain together after being cut by the blades. In lighter soils, like sand or dry loose top soil, the material will pile up or push after being cut by the blade. Use the suggestions listed below:

Topsoil with heavy vegetation (12" to 24" opening):

When cutting undisturbed soils, you will need to open the apron high enough to allow debris to easily enter the scraper bowl. If the apron is opened too high, the rolling up sod will fall out past the apron and hinder the incoming material. If the apron is not adjusted quick enough, the material will bunch or push ahead of the machine. If this happens, you should close the apron and pull out the cut quickly. If you wait too long, you may develop too large a pile to clear the scraper while rising out of the cut. This can cause the power unit to lose traction and possibly cause you to get stuck.

Clay or loamy material: (6" to 12" opening):

To cut clay or loam soils, lower the apron to approximately 6" to 12" between the blades and the bottom of the apron. When you first lower the bowl, you'll see the material being cut by the blades and entering the bowl. As you continue to move forward, small clumps will fall past the apron and develop a small pile ahead of the apron. By limiting this apron opening, the small pile will "blade off" any loose material ahead of the machine. Adjustments should be made if large objects such as rocks or deep gouges are within the cut.

Sand or loose topsoil (15" to 30" topsoil):

Loading sand or loose top soil is the most difficult type of soil to load. In combination with the larger apron opening, you'll want to operate at a faster ground speed. By traveling faster and lowering the blade deeper than normal, it forces the material into the scraper bowl.

We encourage you to experiment with different apron openings to determine the best condition for your jobsite.



The Apron is designed to capture material inside of the scraper bowl and should not be used as a large blade. Obstructions like large rocks or dense piles may cause the apron to bend inward after prolonged exposure to these conditions.



SAFETY GUIDELINES

SAFETY SIGNAL WORDS: Please note the use of signal words such as DANGER, WARNING, and CAUTION paired with the safety messages on your scraper. The appropriate signal word for each safety message has been selected using the following guidelines:

- **DANGER:** Indicates an imminently hazardous situation that, if not avoided, will result in death or serious injury. This signal word is limited to the most extreme situations—typically for machine components which, for functional purposes, cannot be guarded.
- **WARNING:** Indicates a potentially hazardous situation that, if not avoided, could result in death or serious injury. For example, hazards that are exposed when guards are removed. This signal word may also be used to alert against unsafe practices.
- **CAUTION:** Indicates a potentially hazardous situation that, if not avoided, may result in minor or moderate injury. This signal word may also be used to alert against unsafe practices.

Operator safety is a main concern in designing and developing equipment. Designers and manufacturers include as many safety features as possible. However, every year many accidents occur which could have been avoided by extra thought and a more careful approach to handling equipment. The operator can avoid many accidents by observing the precautions in this section. To avoid personal injury, study the following precautions and insist those working with, or for you, follow them.

Replace any CAUTION, WARNING, DANGER or instruction safety decal that is not readable or missing. Locations of decals are indicated in this booklet.

Do not attempt to operate this equipment under the influence of drugs or alcohol.

Review the safety instructions in the operator's manual with all users annually.

Operators should be responsible adults who are familiar with machinery and trained in the equipment's operations. Do not allow persons to operate or assemble this unit until they have read this manual and the owner's manual and have developed a thorough understanding of the safety precautions and scraper operation.

SXL300A001

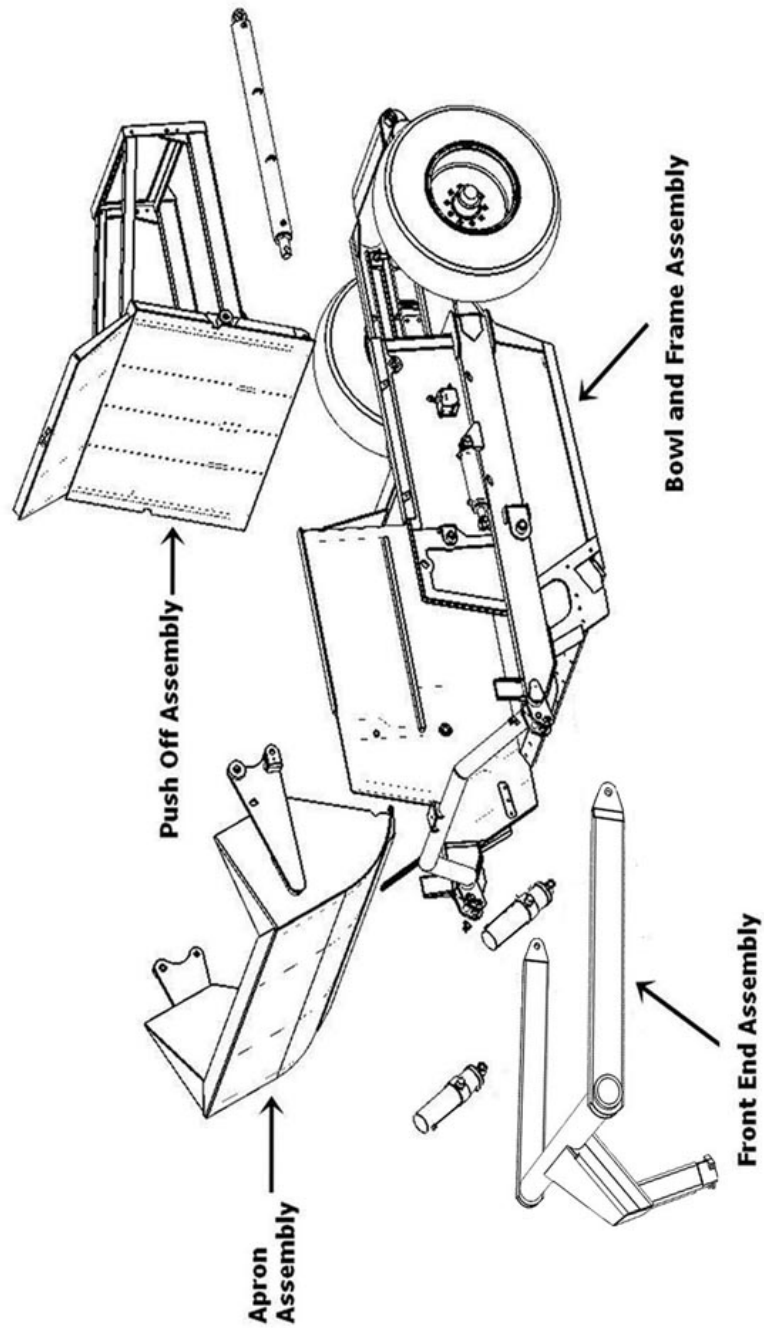

ASHLAND SCRAPERS

Gooseneck Frame Assembly (900-950)

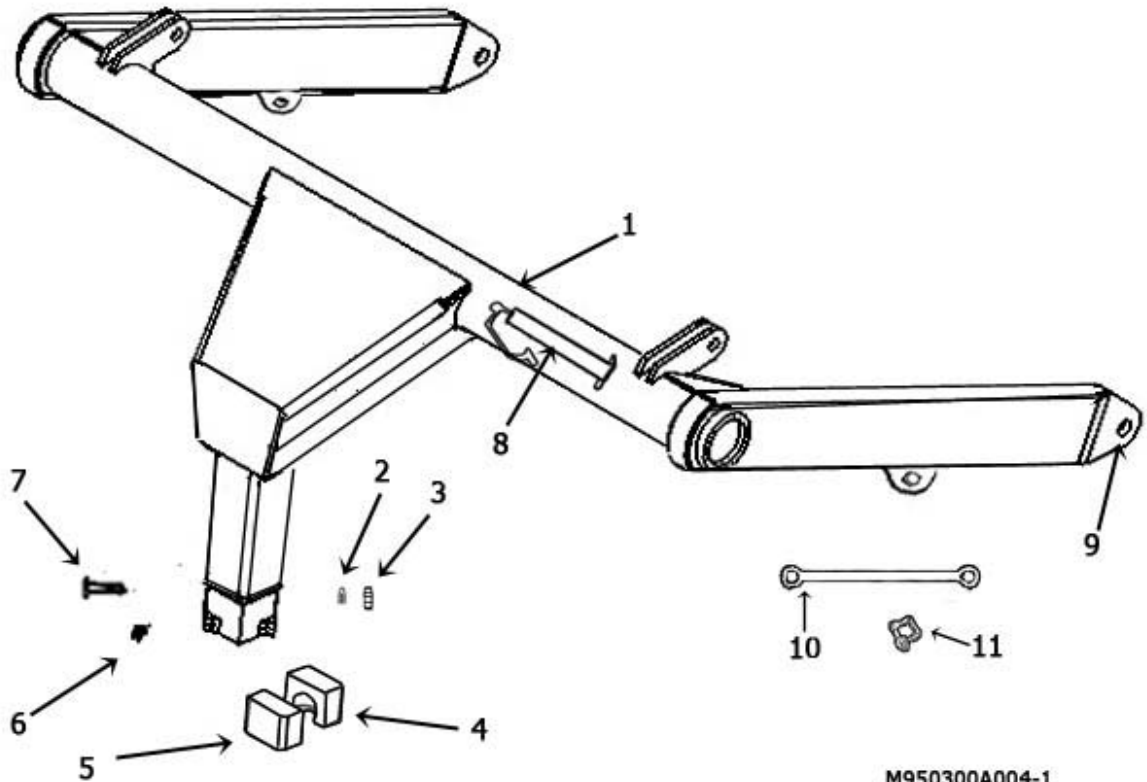

M950300A004-1

KEY	PART	DESCRIPTION	SN 950
1	600104	Gooseneck Frame (950)	22262-XXXXX
2	8110	Lock washer 5/8"	
3	7536	Nut, 5/8" NF	
4	A90004	Cast Socket half, rear	
5	A90005	Cast Socket half, front with zerk hole	
6	A2206	Grease Zerk, Long Shank	
7	AFB-00043	Bolt, 5/8" x 4 1/2" NF	
8	OPT-00001	Hitch Jack	
9	AHF-00028	Grease Fitting 90° 1/8 NPT	
10	A030672-33	Travel Lock	22782-XXXXX
	AFB-00018	Bolt: 1"NC X 3" Gr 8	XXXXX-22781
11	A125006	Snap Ring	22782-XXXXX
	AFW-00001	Washer 1" Flat	XXXXX-22781
	AFN-00012	Nut: 1" NC Gr 8	XXXXX-22781

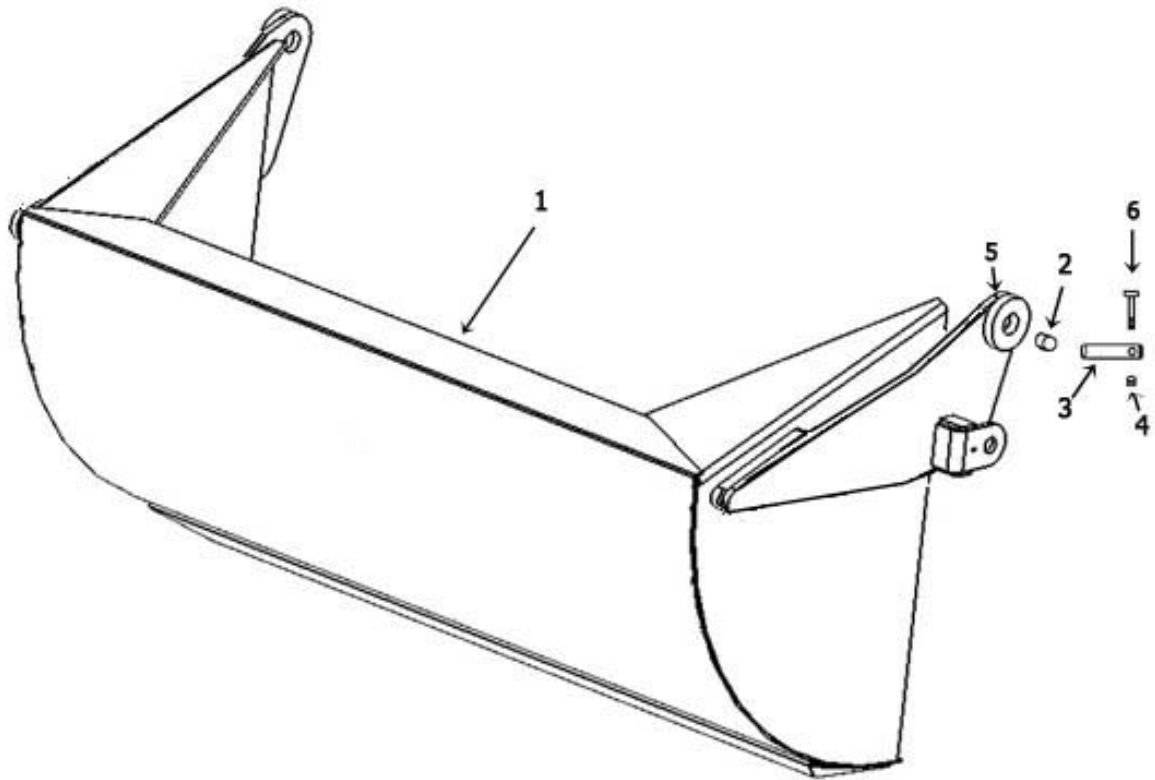

M950300A001

KEY	PART	DESCRIPTION	SN 950
1	600125	Apron	22395-XXXXX
2	A123343	Bushing: 2" OD X 1 1/2 ID X 1 3/4 L	
3	A123337	Pin: 1 1/2" X 5 3/8" L	
4	7450	Nut: 3/8 NC	
5	14505	Grease Fitting	
6	AFB-00049	Bolt: 3/8 NC X 3"	

Bowl & Frame Assembly (900-950)

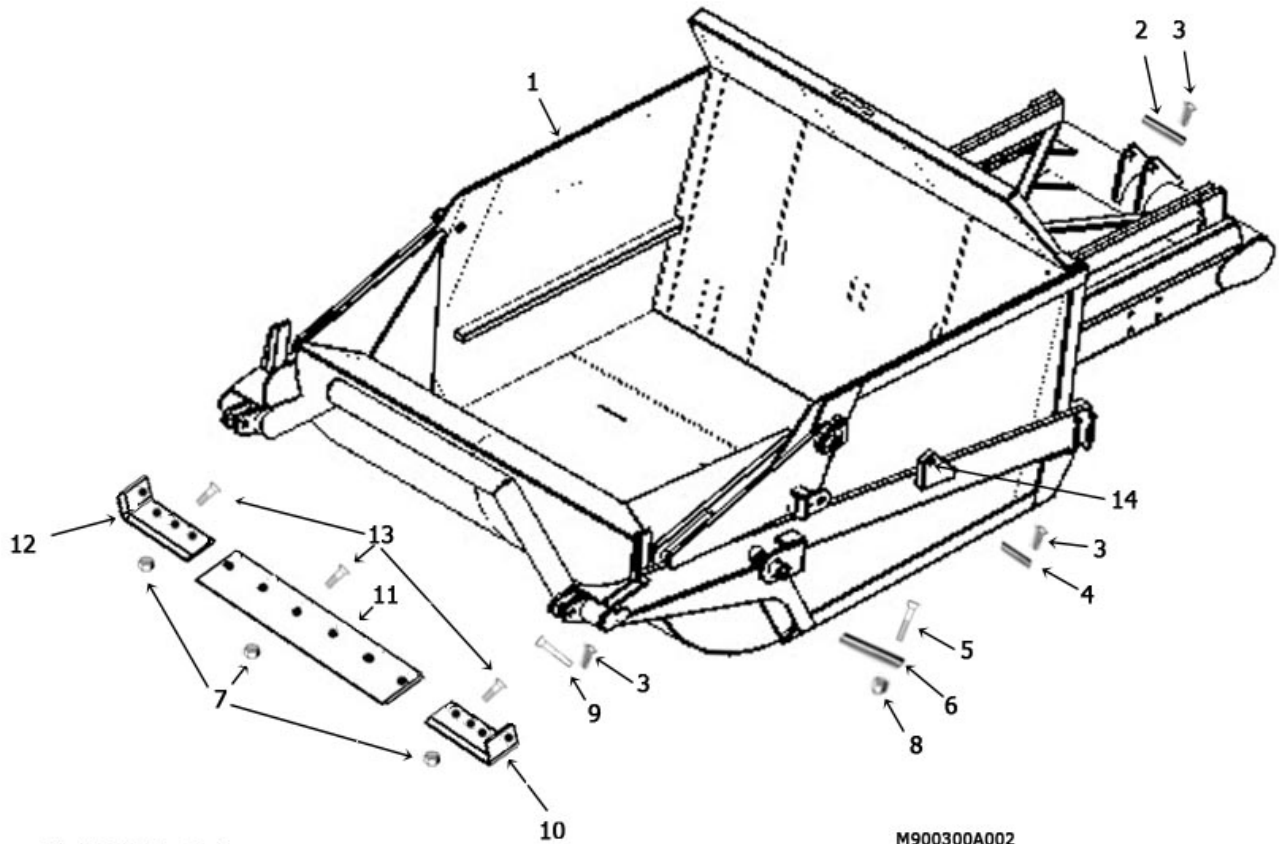

Blade Bolts Required:

		Qty
A8030	PB8P-NC-063-0200	(6)
A8029A	PB8P-NC-063-0200	(4)
A8031A	PB8P-NC-063-0200	(4)

M900300A002

KEY	PART	DESCRIPTION
1	A9055	Bowl and Frame 900-950
2	A8062	Pin, 1-1/4" x 7"
3	AFP-00002	Cotter Pin, 3/16" X 1 3/4"
4	A1217	Pin, 1" x 3-1/2"
5	AFB-00054	Bolt: 1/2" NC X 3 1/2"
6	A8056	Pin, 1-3/4" x 7-3/4"
7	7530	Nut: 5/8" NC
8	AFN-00011	Nut: 1/2" NC
9	A10168	Pin: 1/1/8" X 4 1/4"
10	A8031A	Left Cutting Edge

ASHLAND SCRAPERS**Bowl & Frame Assembly (900-950)**

KEY	PART	DESCRIPTION
11	A8030	Center Cutting Edge
12	A8029A	Right Cutting Edge
13	PB8P-NC-063-0200	Plow Bolt, 5/8" x 2"
14	14505	Grease Fitting, 1/8 UPT

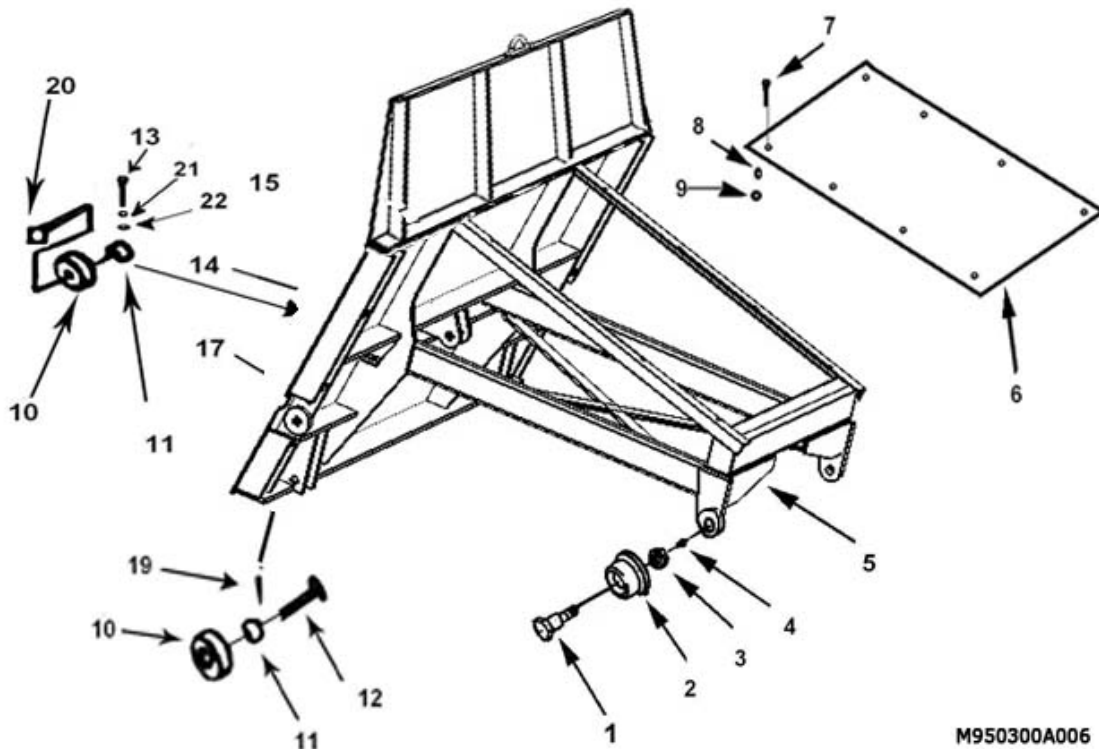
Push Off Assembly (900-950)

M950300A006

KEY	PART	DESCRIPTION
1	A10008	Shoulder Pin, 1 5/8" to 1 1/4" with zerk in threaded end
2	A123306	Roller, gate rear with flange type
3	AFN-00024	Jam Nut, 1 1/4" NF
4	14505	Grease Fitting, 1/8" NPT straight
5	A9056	Push Off Gate
6	A9058	Dirt Shield
7	AFB-00015	Bolt: 1/2" NC X 1 1/2"
8	8100	Lockwasher, 1/2"
9	AFN-00011	Nut, 1/2" NC
10	A10164	Roller: 4 1/4 OD x 1 3/4 ID
11	A10163	Bushing: 1 3/4" OD X 1 1/4" ID
12	A6007A	Pin: 1 1/4" X 4 1/8" Lg.
13	7036	Bolt: 1/2 NC X 2 Gr 8
14	A125020	3/2" Greaseline
15	A123323-40	Double Hole Tab
16	A125026	Bulkhead Nut

ASHLAND SCRAPERS**Push Off Assembly (900-950)**

KEY	PART	DESCRIPTION
17	A125021	54" Greaseline
18	A125019	Grease Fitting 1/4 - 28: 54 L
19	AFP-00001	Cotter Pin: 1/4 X 3 Lg.
20	A123288	Pin: 1 1/4 X 3 1/4 Tab Head
21	8100	1/2" Lockwasher
22	7500	Nut: 1/2 NC

Pole & Axle Assembly (900-950)

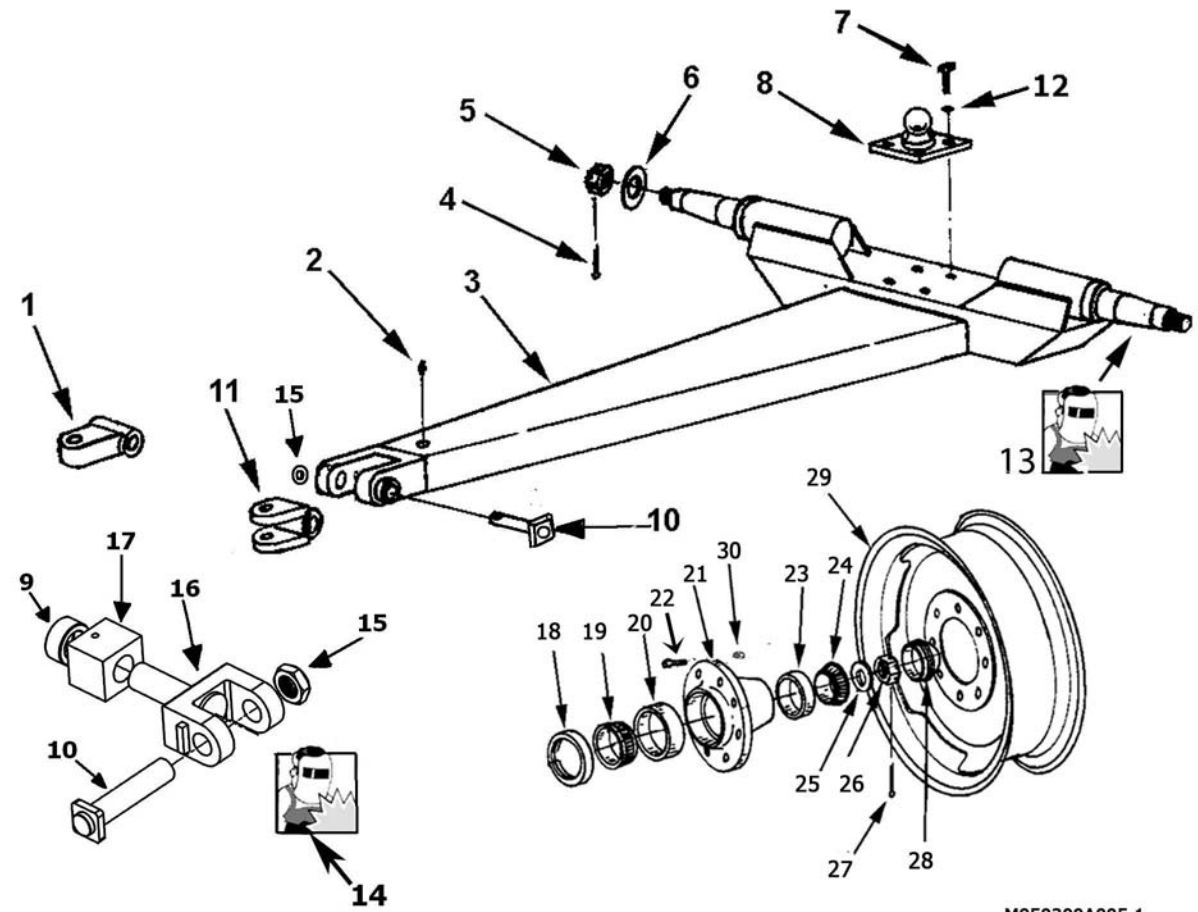

M950300A005.1

KEY	PART	DESCRIPTION	SN 950
1	A10033A	Single Lip Hitch	
2	14505	Grease Fitting, 1/8 NPT	
3	A9059	Pole	
4	AFP-00002	Cotter Pin, 3/16" X 1 3/4"	
5	AFN-00010	Nut, castellated, 1 1/4" NF	
6	A8027	Washer, special, 1 1/4" flat	
7	AFB-00005	Bolt, 3/4" NC X 2 1/2" L	
8	A40006	Ball Swivel	
9	A030568-01	Hitch Collar	
10	600053	Pin, Swivel Hitch	
11	A10033	Double Lip Clevis Hitch	
12	AFW-00002	Lockwasher, 3/4"	
13	A9062	Weld, Spindle Blank	
14	A031076W	Yoke Hitch Rebuild Kit (Containing items: 9,10,15,16,17)	
15	500433	Nut: Jam	
16	A030168-3A	Swivel Yoke Assembly	
17	A030568-1	Swivel Block	
18	A8020	Grease Seal (CR 35062)	
19	A9061	Bearing Cone, inner	
20	A8022	Bearing Cup, inner	
21	A125319	Hub	22410-XXXXX
	A8023	Hub	XXXXX-22409



ASHLAND SCRAPERS**Pole & Axle Assembly (900-950)**

KEY	PART	DESCRIPTION	SN 950
22	A125320	Wheel Stud	22410-XXXXX
	A4519	Wheel Bolt, 9/16" NF	XXXXX-22409
23	A8024	Bearing Cup, outer	
24	A8025	Bearing Cone, outer	
25	A8027	Spindle washer, special	
26	AFN-00005	Spindle Nut	
27	AFP-00002	Cotter Pin, 3/16" X 1 3/4"	
28	A8026	Hub Cap	
29	A6022A	Wheel, 16.1 X 11" DC	
30	A125321	Nut: Wheel 5/8"	22410-XXXXX

ASHLAND SCRAPERS

Wheel Assembly (900-950)

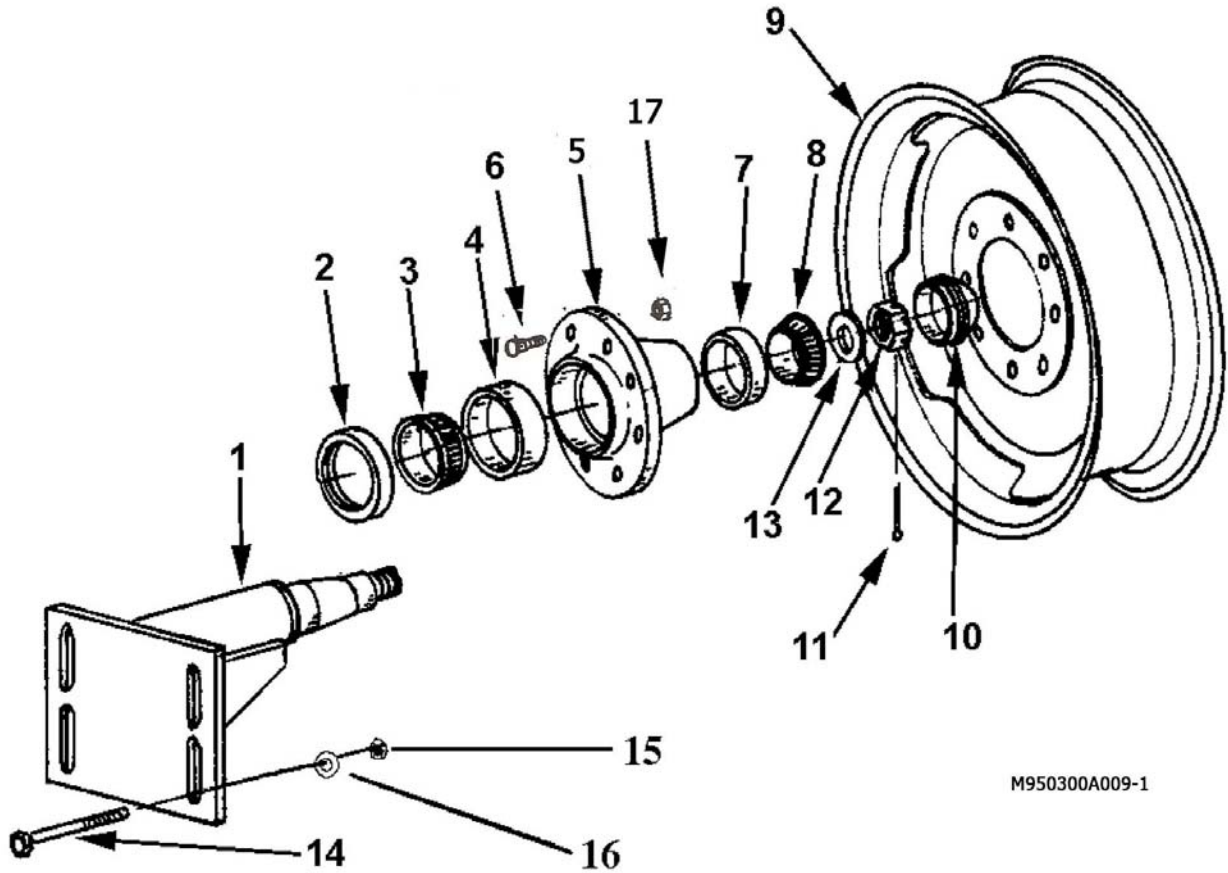

M950300A009-1

KEY	PART	DESCRIPTION	SN 950
1	A9060	Spindle, Rear with flange base plate	
2	A8020	Grease Seal (CR 35062)	
3	A9061	Bearing Cone, inner	
4	A8022	Bearing Cup, inner	
5	A125319	Hub	22410-XXXXX
	A8023	Hub	XXXXX-22409
6	A125320	Stud: Wheel 5/8"	22410-XXXXX
6	A4519	Wheel Bolt, 9/16" NF	XXXXX-22409
7	A8024	Bearing Cup, outer	
8	A8025	Bearing Cone, outer	
9	A6022A	Front Wheel 16.1 X 11" DC	
9	A6023	Rear Wheel 24" x 15"	
10	A8026	Hub Cap	
11	AFP-00002	Cotter Pin, 3/16" x 1-3/4"	
12	AFN-00005	Spindle Nut	
13	A8027	Spindle washer, special	
14	AFP-00001	Bolt, 1" NC x 6-1/2" long	
15	AFN-00012	Nut, 1" NC	
16	AFW-00001	Flat Washer, 1"	
17	A125321	Nut: Wheel 5/8"	22410-XXXXX

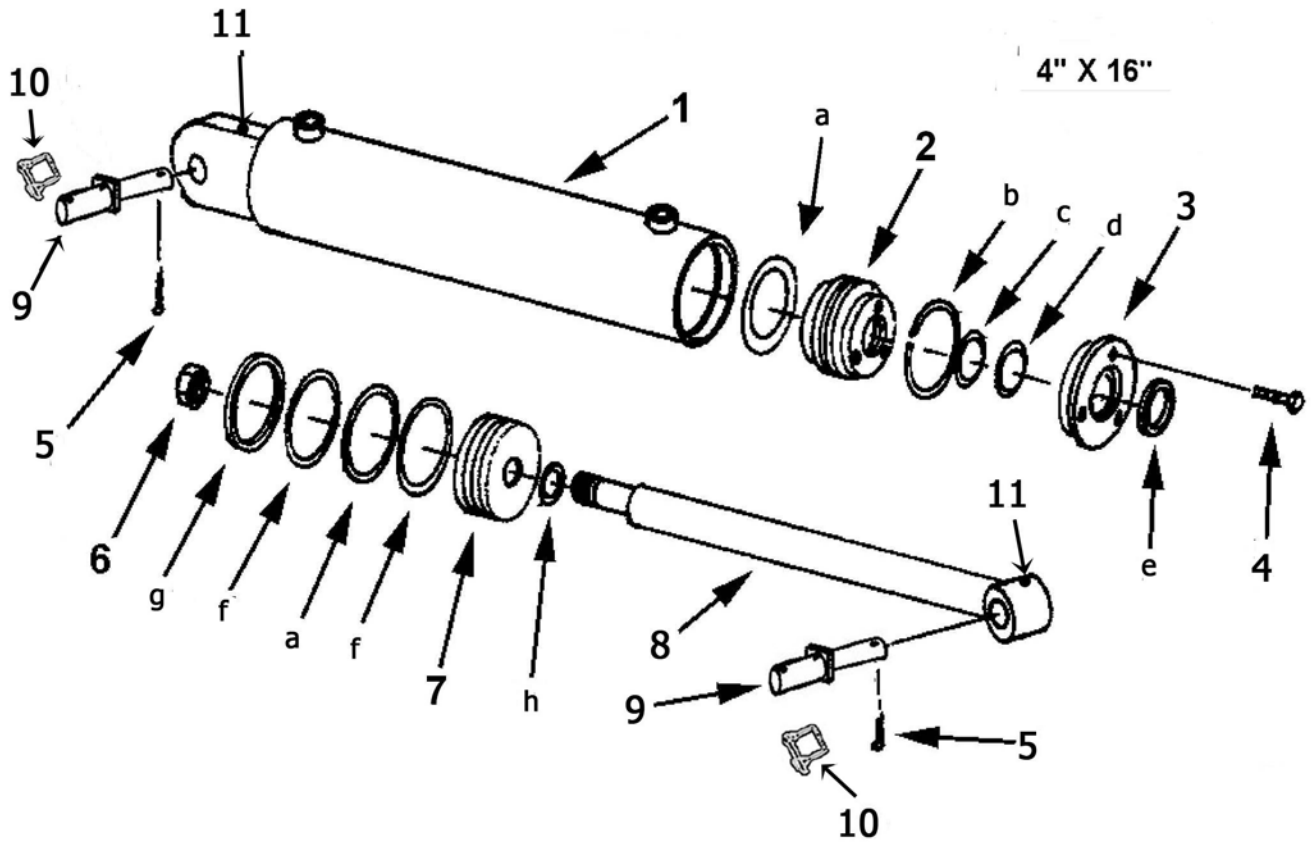
Lift Cylinder (#A416H118) 4" X 16"

M950350P001-2

KEY	PART	DESCRIPTION	SN 950
	A416H118	LIFT CYLINDER 4" X 16"	
1	A45H04	Barrel Assembly	
2	A300H11	Head Gland	
3	A300H13	Head Cap	
4	A22H18	Capscrew, 1/4" x 1"	
5	AFP-00002	Cotter Pin, 3/16" X 1 3/4"	22782-XXXXX
	AFP-00003	Cotter Pin, 3/16" X 1 1/2"	XXXXX-22781
6	A300H03	Piston Nut	
7	A300H07	Piston, 4"	
8	A45H03-118	Shaft, 1-1/2" diameter	
9	A123215-43	Pin: 1 1/8 X 6 3/8" w/Sq. Head	22782-XXXXX
	A10168	Pin, 1 1/8" X 4 1/4" Rod End	XXXXX-22781
	A45003	Pin, 1-1/8" x 3-1/4" Barrel End	XXXXX-22781
10	A125006	Snap Ring	22782-XXXXX
11	14505	Grease Fitting	
	A300H14B	Cylinder Seal Kit ,containing: (a-h)	
a		O-ring, 4" OD x 3/16"	
b		Retainer Ring	
c		O-Ring 1 1/2" ID X 1/8"	
d		Backup Washer	
e		Wiper Seal	
f		Backup Washer, 4" OD	

ASHLAND SCRAPERS**Lift Cylinder (#A416H118) 4" X 16"**

KEY	PART	DESCRIPTION	SN 950
g		Cast Iron Ring	
h		Backup Ring 1" OD	

ASHLAND SCRAPERS

Apron Cylinder (#A125050) 4" X 13"

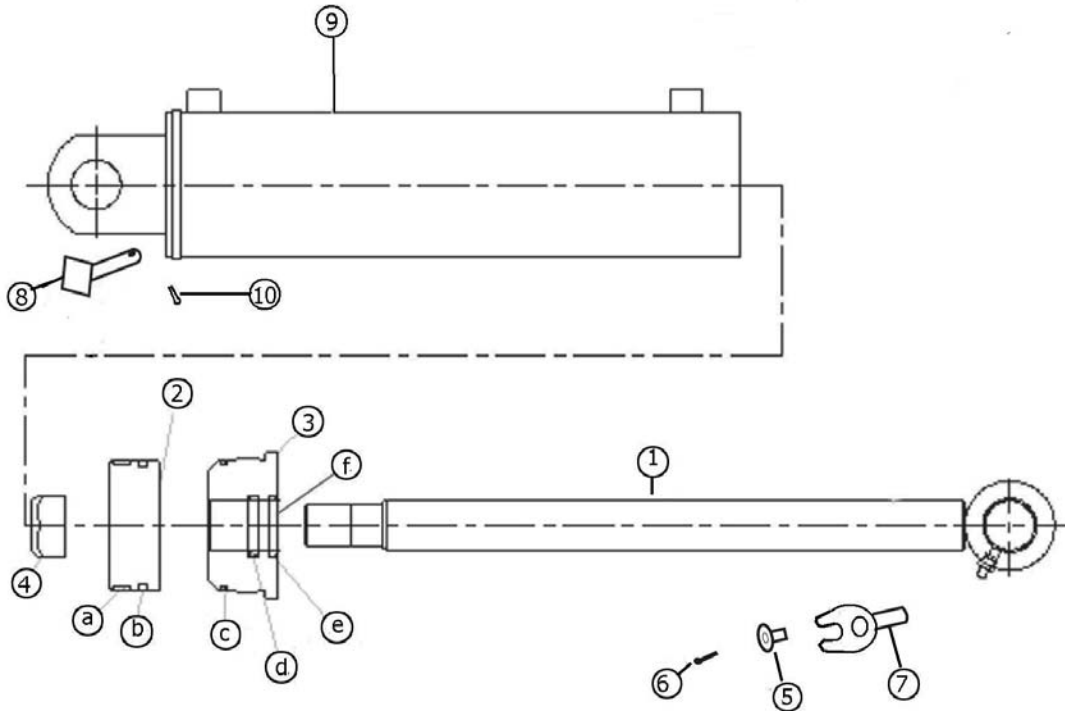

A350P004

KEY	PART	DESCRIPTION	SN 950
	A125050	APRON CYLINDER 4" X 13"	22395-XXXXX
1	A125050-01	Rod 1-3/4" with welded eye	
2	A125050-02	Piston	
3	A125050-03	Gland, Threaded	
4	A125050-04	Lock Nut, 1-1/8" NF	
5	A123351	Pin Keeper Bushing	
6	AFB-00019	1/2" x 1 1/2" Gr 8 Bolt	
7	A123362	Pin: Cyl. Rod End 1 1/2 X 4 1/2 w/ Tab	
8	A123363	Pin: Cyl. Base End 1 1/2 X 4 1/8"	
9	A125050-06	Cylinder Barrel	
10	8602	Cotter Pin: 1/4 X 2	
	A125050-05	Seal Kit Containing (a-f)	
a		Nylon Wear Ring	
b		FSP Seal	
c		O-Ring	
d		Backup Washer	
e		Hallite Rod Seal	
f		Snap in Rod Wiper	

ASHLAND SCRAPERS

Parts - Cylinder - Push Off (400060) 4" x 50"

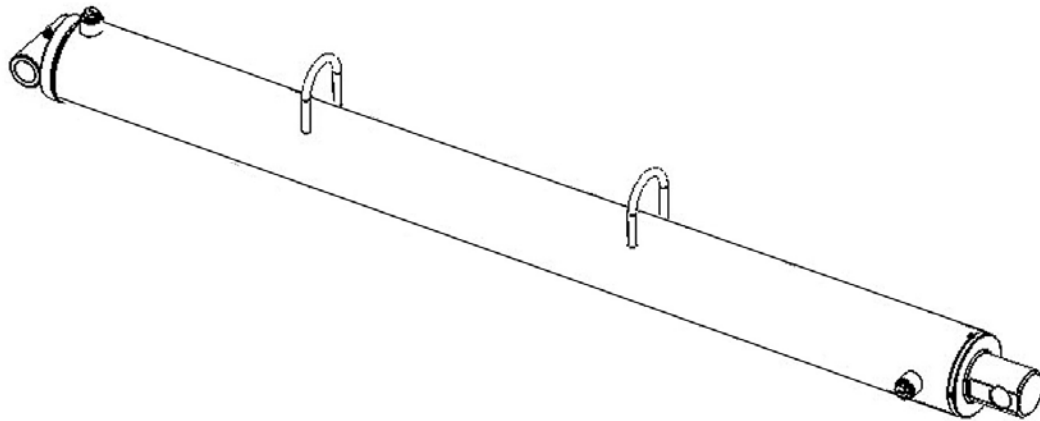

PART	DESCRIPTION	SN 950
400060	PUSH OFF CYLINDER 4" X 50"	23755-XXXXX
J432572A	Seal Kit	23755-XXXXX

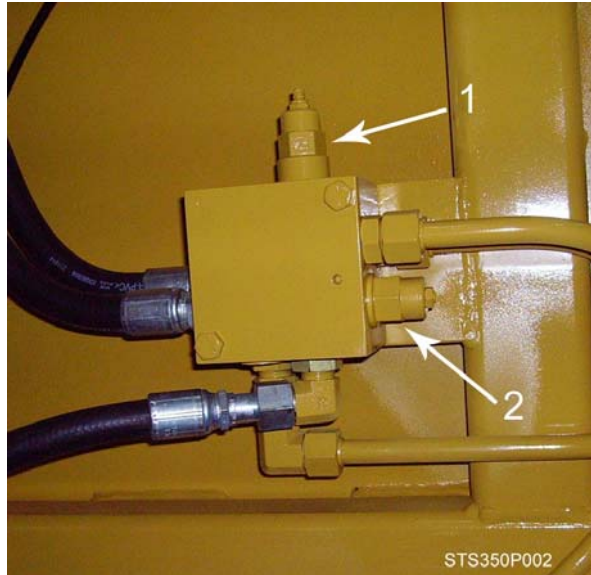
ASHLAND SCRAPERS
Hydraulic Manifold (#A125174)

KEY	PART	DESCRIPTION
1	A125162-02	PUSHOFF SEQUENCE CARTRIDGE
2	A125162-01	COUNTER BALANCE CARTRIDGE

SETTING THE APRON AND PUSHOFF VALVE

The manifold block containing the pushoff sequence valve cartridge and apron sequence valve cartridge is used to control two hydraulic circuits with one hydraulic remote. When the tractor hydraulic remote is activated, oil flows first to the apron cylinders until they are fully extended. Once the cylinders are fully extended, the apron circuits' hydraulic pressure begins to increase. Once the pressure threshold is surpassed (which is adjustable. See adjustment section), the sequence valve diverts the oil flow to the pushoff's hydraulic circuit. Once the push off is completely extended the operator then reverses the tractors hydraulic remote. The counterbalance valve will hold the apron open until the push off is fully retracted. The Apron sequence valve then opens and allows the apron to close.

Setting the valves:

STEP 1 PUSHOFF SEQUENCE VALVE

Loosen the lock nut (9/16") on the sequence valve cartridge. Turn the setscrew (4mm) clockwise until the front apron rises before the push-off begins to advance. (Earthmover should be empty) Turn the adjustment screw an additional 1/4 turn clockwise and tighten jam nut.

STEP 2 COUNTER BALANCE VALVE

Loosen the lock nut (9/16") on the counterbalance valve cartridge. Turn the setscrew (4mm) counter-clockwise until the apron holds in a raised position while rear gate is being retracted. Turn adjustment screw an additional 1/4 turn, tighten jam nut. DO NOT tighten adjusting screw more than necessary.

ASHLAND SCRAPERS

Hydraulic Valve Ports Assembly

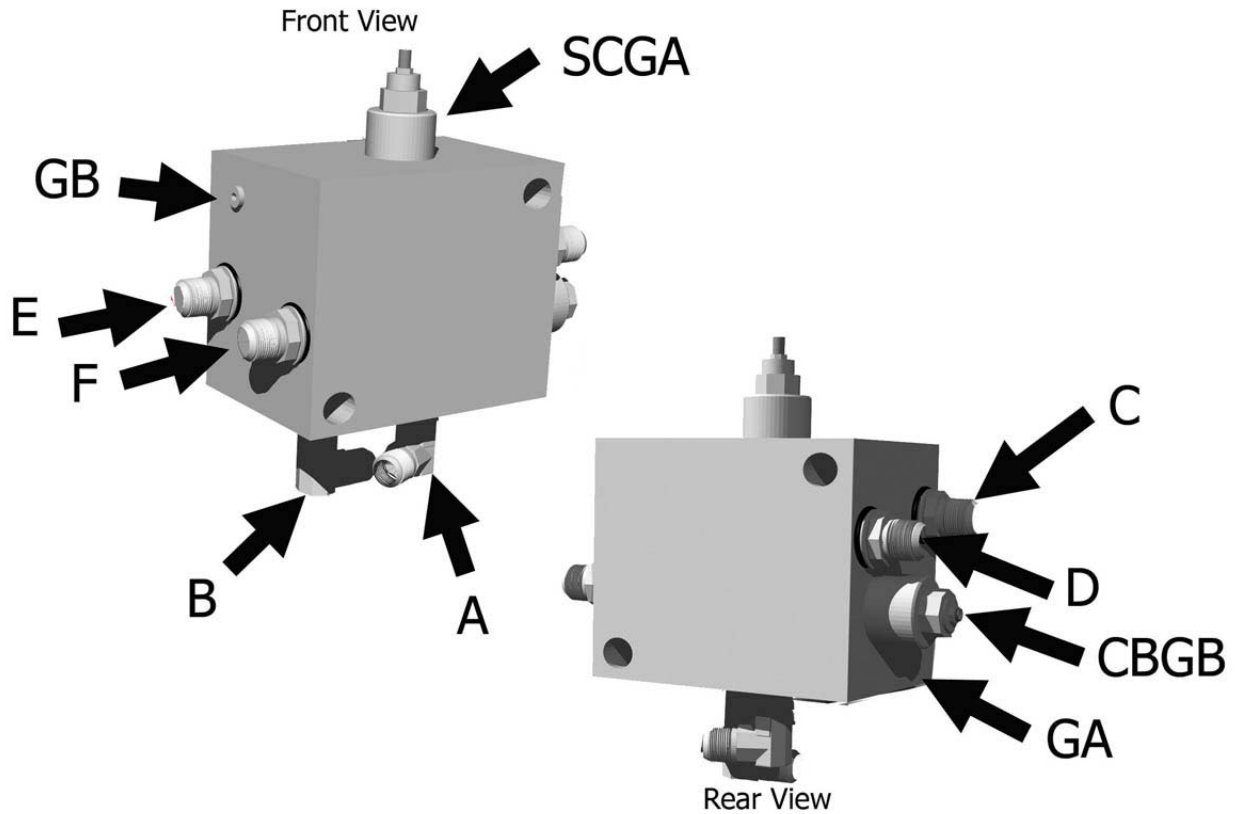

The lettering for the port locations are stamped on the block

A350P010

KEY	PART	DESCRIPTION
A		Supply Line
B		Pushoff Cyl. (Rod End)-Apron Cyl., Right side (Rod end)-Supply Line
C		Pushoff Cylinder, (Base End)
D		Apron Cylinder, Right side, (Base End)
E		Apron Cylinder, Left side, (Rod End)
F		Apron Cylinder, Left side, (Base End)
CBGB		Counterbalance Valve, adjustable
SCGA		Sequence Valve, adjustable
GA		Pressure test port
GB		Pressure test port

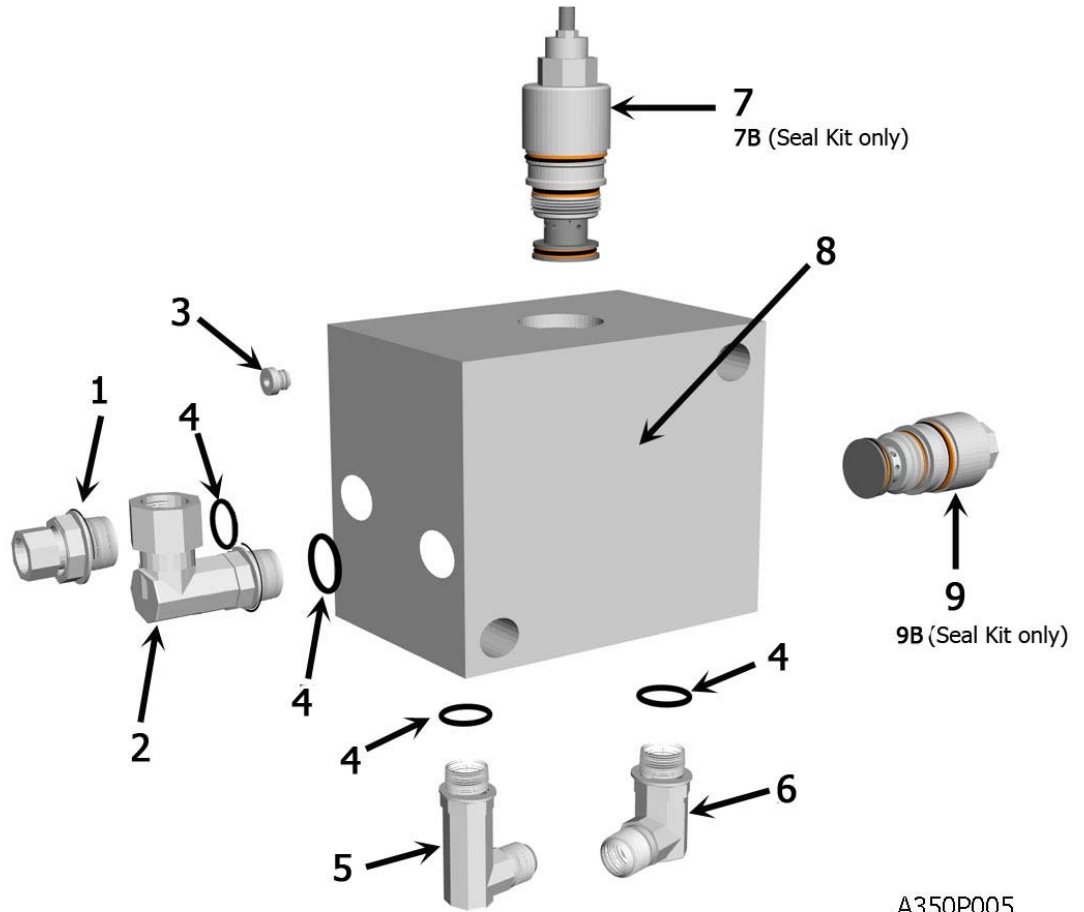

A350P005

KEY	PART	DESCRIPTION
1	AHA-00043	Adapter: Str. Sw. 1 1/16 M ORB X 1/2 FP
2	AHA-00048	Adapter: 90 Deg. Swiv. 1 1/6 M ORB X 1/2 FP
3	AHA-00046	6 ORB Plug
4	AHS-00153	O-Ring for 12 M ORB Fitting
5	AHA-00047	Adapter: 90 Deg. XL 3/4 MJX 1 1/6 M ORB
6	AHA-00044	Adapter: 90 Deg. 3/4 MJ X 1 1/6 M ORB
7	A125162-02	Valve: Sequence Cartridge for Ver. III & IV
8	A125174	Valve: Manifold Block IV Body
9	A125162-01	Valve: Counterbalance Cartridge for Ver. III & IV
9B	A125162-01 KIT	Seal Kit for A125162-01 Valve Cartridge
7B	A125162-02 KIT	Seal Kit for A125162-02 Valve Cartridge

ASHLAND SCRAPERS

Hydraulic Plumbing Front (I-950)

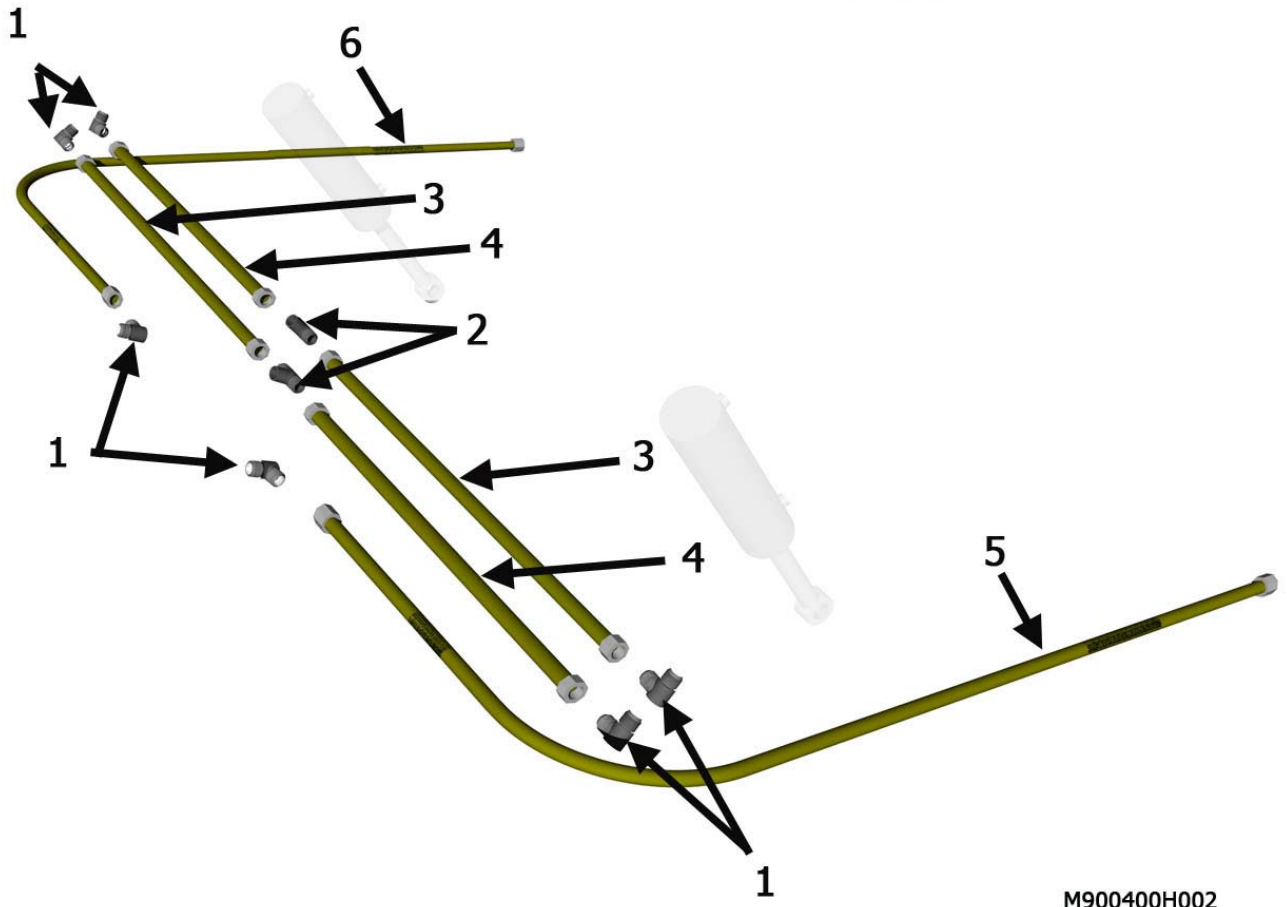

KEY	PART	DESCRIPTION
1	AHA-00019	Adapter: 90 Deg. 3/4 MJ X 3/4 MJ
2	AHA-00022	Adapter: T 3/4 MJ X 3/4 MJ X 3/4 MJ
3	A125063	Tube Assembly: 3/4" X 32 3/4"
4	A125064	Tube Assembly: 3/4" X 30 1/2"
5	A125272	Tube Assembly: I-900 Left Front Arm
6	A125273	Tube Assembly: I-900 Right Front Arm

ASHLAND SCRAPERS

Hydraulic Plumbing Rear (I-950)

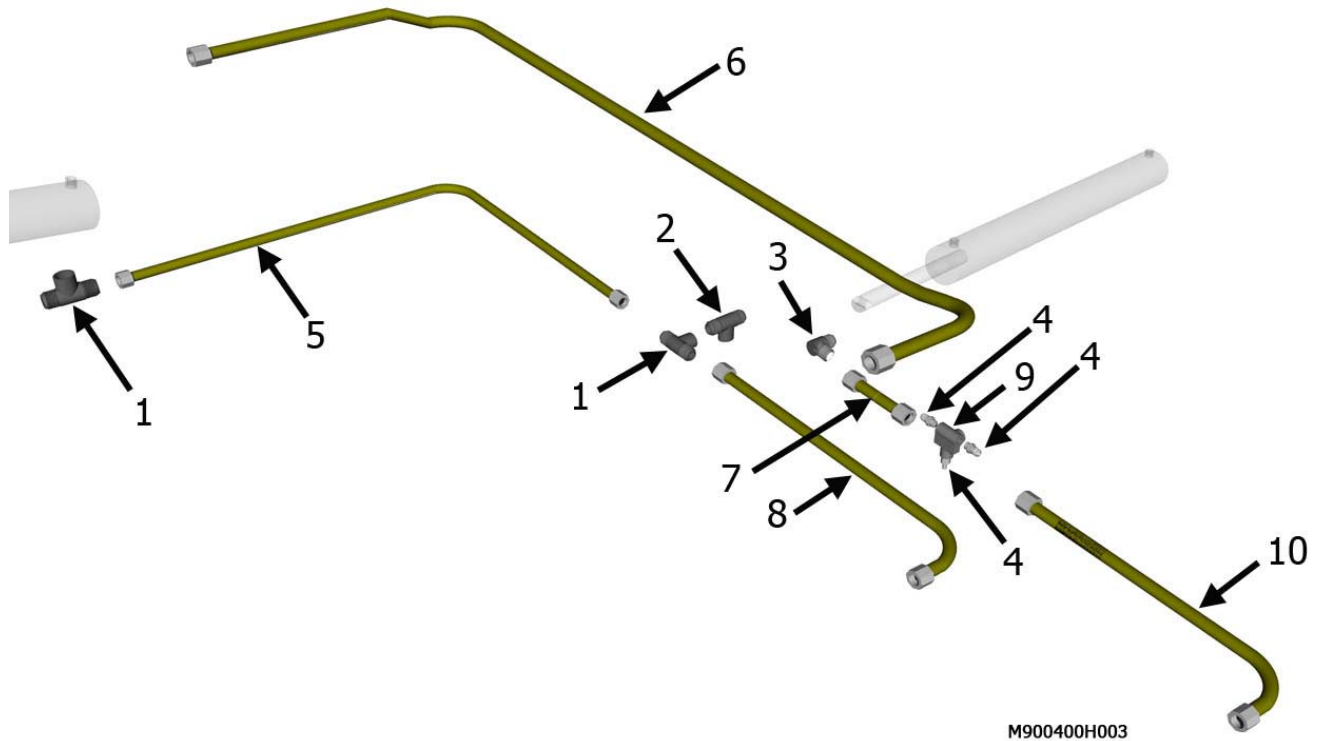

KEY	PART	DESCRIPTION
1	AHA-00022	Adapter: T 3/4 MJ X 3/4 MJ X 3/4 MJ
2	AHA-00049	Adapter: T 3/4 MJ X 3/4 MJ X 3/4 FJ Swiv.
3	AHA-00019	Adapter: 90 Deg. 3/4 MJ X 3/4 MJ
4	AHA-00006	Adapter: Str. 3/4 MJ X 3/4 MP
5	A125060	Tube Assy: 3/4" X 77 3/4" W/ 12 JIC Nuts and Sleeve
6	A125182	Tube Assy:
7	A155-H21	Tube Assy:
8	A125183	Tube Assy:
9	AHV-00001	Valve: Pressure Relief (in-line)
10	A125184	Tube Assy:

ASHLAND SCRAPERS
Parts - Hydraulic Clamps

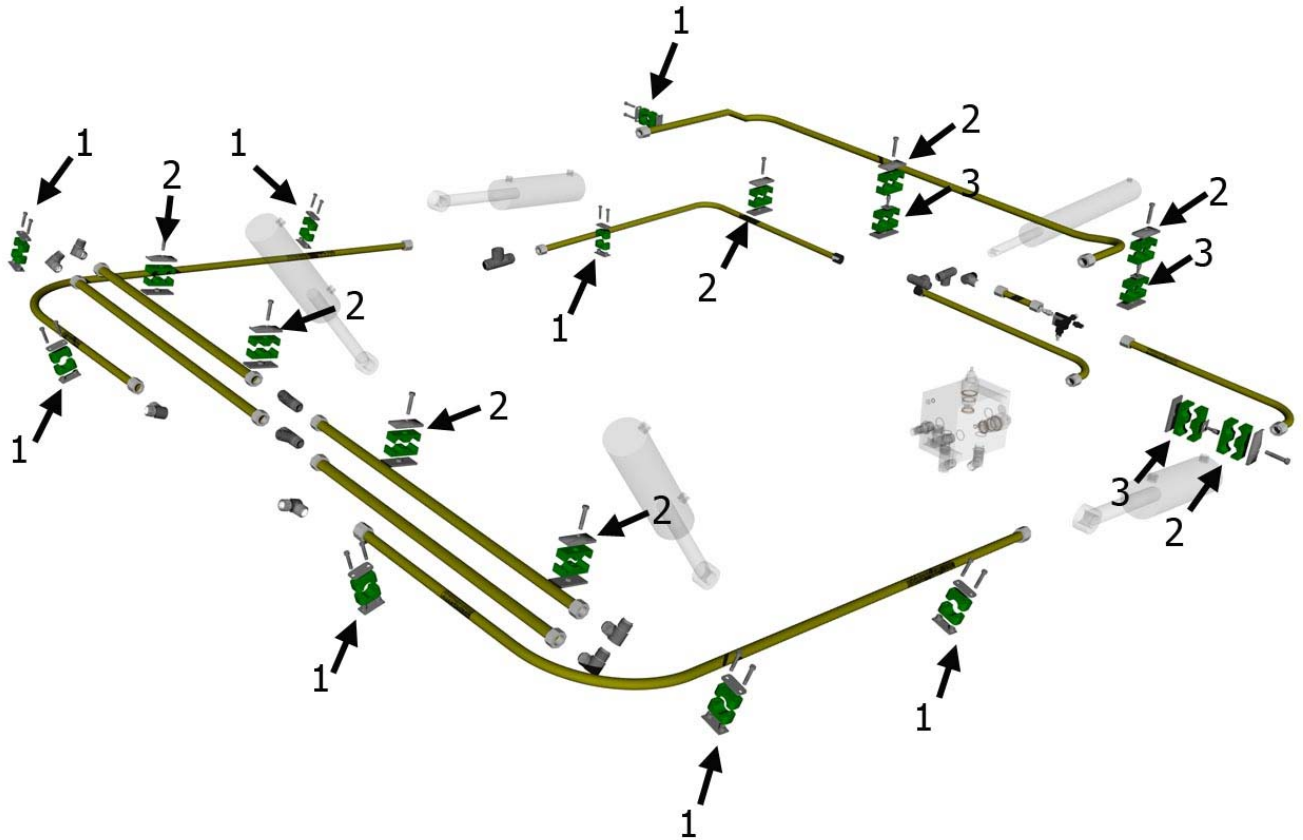

M900400H005

KEY	PART	DESCRIPTION
1	AHL-00001	Clamp: Hydraulic Line - 1 Tube
2	AHL-00002	Clamp: Hydraulic Line - 2 Tube Ass'y
3	AHL-00022	Clamp: Ass'y Hyd. Line - 1 Tube

ASHLAND SCRAPERS

Hydraulic Hoses (I-950))

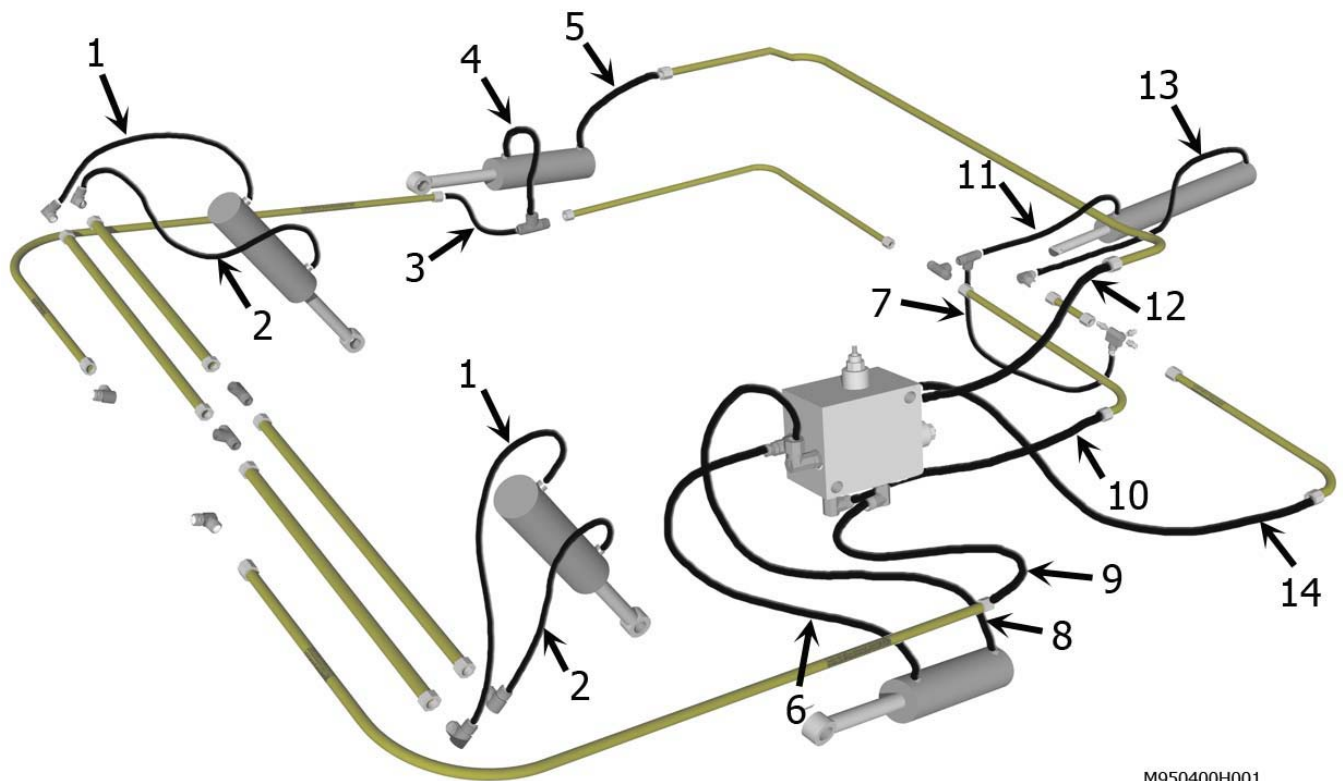

M950400H001

KEY	PART	DESCRIPTION
1	A900-H12	Hose Assembly: 1/2" x 19-1/2" Lift Cyl. Base End Port
2	A900-H11	Hose Assembly: 1/2" x 25" Lift Cyl. Rod End Port
3	A900-H10	Hose Assembly: 1/2" X 42" R. Tube - Front Arm
4	A900-H09	Hose Assembly: 1/2" x 25-1/2" R. Apr. Cyl. Rod End Port
5	A900-H08	Hose Assembly: 1/2" x 18" R.Apr.Cyl. Base End Port
6	A900-H21	Hose Assembly: 1/2" X 23" L. Apr. Cyl. Rear Tube
7	A900-H05	Hose Assembly: 1/2" X 17" PRV-Tube @ Bowl Rear
8	A900-H20	Hose Assembly: 1/2" X 16" L. Apron Cyl. Top Tube
9	A900-H26	Hose Assembly: 1/2" X 48" to Valve Block
10	A900-H25	Hose Assembly: 1/2" X 20" Valve Port to Tube @ Bowl L. Rear
11	A900-H06	Hose Assembly: 1/2" x 16" Tube - Push Off Cyl. Rod End
12	A900-H22	Hose Assembly: 1/2" X 20" Valve Port to D to Tube @ Bowl Rear
13	A900-H24	Hose Assembly: 1/2" X 50" P.O. Cyl. Base End Port
14	A900-H23	Hose Assembly: 1/2" X 21" Valve Port to C to Tube @ Bowl L.Rear

ASHLAND SCRAPERS

Decals Illustration (I-950)



↑
1



↑
2



↑
3



↑
4



↑
5



↑
7



↑
6

ASHLAND SCRAPERS**Decals**

KEY	PART	DESCRIPTION
1	750464	High Pressure Fluid Warning
2	ADS-00011	Pinch Point
3	ADS-00019	Grease
4	ADS-00061	Small Ashland
5	ADs-00062	Large Ashland
6	ADS-00055	950XL2
7	ADS-00065	AI Logo

ASHLAND SCRAPERS**Maintenance Check list**

1. Grease all zerks.
 - a) Every 8 hours of operation.
 - b) See Lubrication Points section on next page.
2. Greasing the hubs.
 - a) Re-pack wheel bearings after 300 hrs of operation.
 - b) Completely clean grease out of hub and bearings every 1200 hours of operation.
3. Check tire pressure.
 - a) See Tire Pressure Chart.
4. Check all pins for signs of wear.
 - a) Daily
5. Check wheel lug nut torque.
 - a) After first 2 hours of operation.
 - b) Recheck daily for next 2 weeks.
 - c) Tighten wheel lug nuts in a star pattern.
 - d) Torque wheel lug nuts (See Torque Specifications).
6. Check and retighten all bolts.
 - a) After initial 10 hours of use.
 - b) Again after 50 hours of use.
 - c) See Torque Specifications.
7. Inspect cutting edges.
 - a) Daily
 - b) Replace cutting edges when center blade has been worn to approximately 6" and side edges worn to approximately 4".



CAUTION! Failure to replace worn cutting edges may result in unnecessary wear to the earthmover sides and floor.

Note: Please specify left or right "L" shaped cutting edges when ordering replacements. Left or right side parts are determined by viewing from rear of the scraper.

Lubrication Points

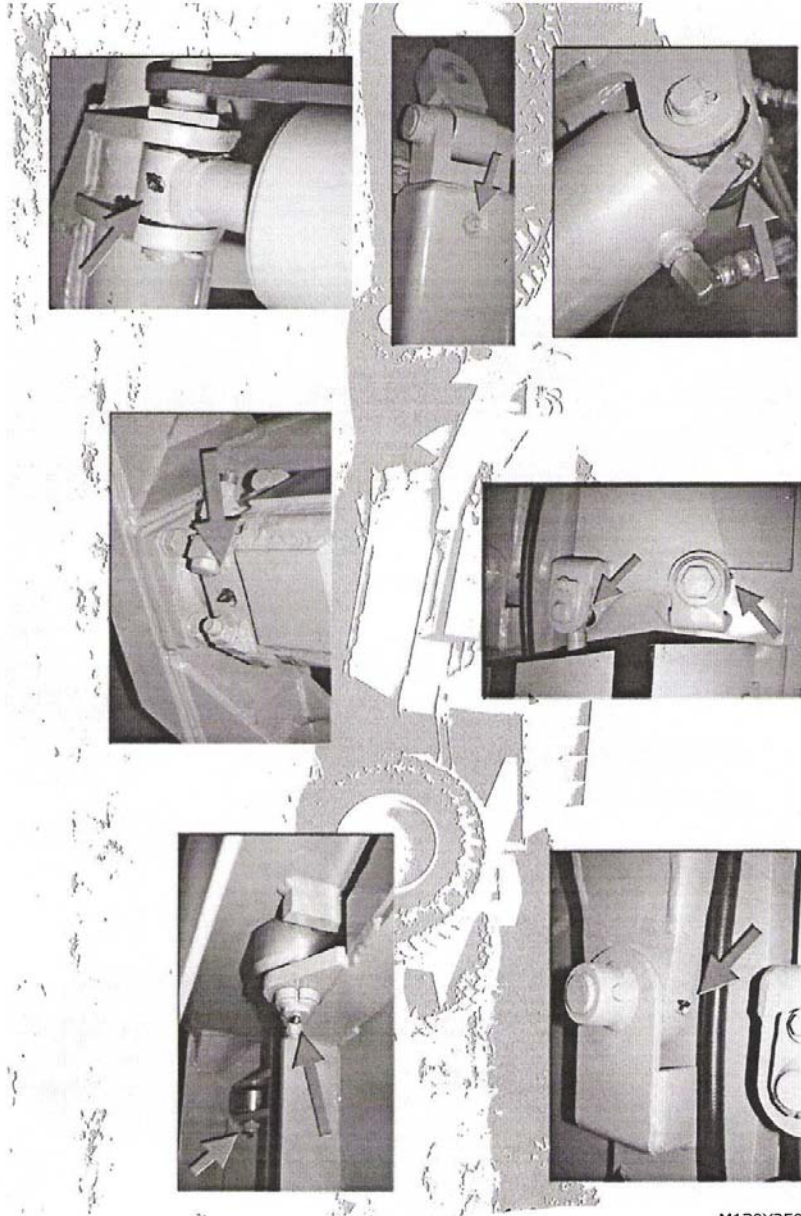

M130X250M004

1. Hitch – Horizontal and vertical pins.
2. Lift Cylinders – Rod end & Trunion; Both left & right sides.
3. Front Arm Pivot Joint – Both left & right sides.
4. Apron Cylinders – Rod clevis pin; Both left & right sides.
5. Apron Pivot Pin – Both left & right sides.
6. Hold-down Rollers – Both left & right sides.
7. Floor Rollers – Both left & right sides.
8. Tapered Rollers – Both left & right sides.

TORQUE SPECIFICATIONS

<i>Bolt</i>	<i>Torque</i>		
<i>Diameter</i>	<i>Ft-lbs</i>		
<i>1/4</i>	<i>12</i>		
<i>5/16"</i>	<i>25</i>		
<i>3/8"</i>	<i>45</i>		
<i>7/16"</i>	<i>70</i>		
<i>1/2"</i>	<i>110</i>		
<i>9/16"</i>	<i>150</i>		
<i>5/8"</i>	<i>220</i>		
<i>3/4"</i>	<i>380</i>		
<i>7/8"</i>	<i>600</i>		
<i>1"</i>	<i>900</i>		
<i>1-1/8"</i>	<i>1280</i>		
<i>Lug Nuts</i>	<i>85-100 /9 yd</i>	<i>450- 11/13 yd</i>	<i>750-15 yd & up</i>

LUBRICATION

1. Grease all zerks every 8 hrs of operation with high quality, general-purpose grease.
 - a) Grease until grease flows from around pin.

Lubrication Points (see III.)

1. Hitch – Horizontal and vertical pins.
2. Lift Cylinders – Rod end & Trunion; Both left & right sides.
3. Front Arm Pivot Joint – Both left & right sides.
4. Apron Cylinders – Rod clevis pin; Both left & right sides.
5. Apron Pivot Pin – Both left & right sides.
6. Hold-down Rollers – Both left & right sides.
7. Floor Rollers – Both left & right sides.
8. Tapered Rollers – Both left & right sides.

ASHLAND SCRAPERS**Tire Service**

The task of servicing tires and wheels can be extremely dangerous and should be performed by trained personnel only, using the correct tools and following specific procedures. Do not attempt to mount, demount or inflate a tire if you do not have the proper equipment and experience to perform the job. Call a qualified repair service to inspect the assembly and make necessary repairs. Failure to heed warnings could lead to serious injury or death.

Visually inspect tires and wheels daily. Carefully inspect any rim and tire assembly that has been run underinflated or flat before reinflating the tire to make sure there is no damage to either the rim or tire.

- ALWAYS wear personal protection equipment such as gloves, footwear, eye protection, hearing protection and head gear when servicing tire and wheel components.
- DO NOT operate with damaged rims, tire cuts or bubbles, missing lug bolts or nuts or damaged rims.
- ALWAYS maintain the correct tire pressure. NEVER exceed recommended tire inflation pressure.
- INSPECT any rim and tire assembly that has been run flat or severely underinflated before reinflating the tire. Damage to the rim and tire may have developed.
- NEVER inflate a tire that has lost air pressure or has been run flat without determining and correcting the problem.
- NEVER try to repair wheel, rim, or tire components parts. Parts that are cracked, worn, pitted with corrosion, or damaged must be discarded, and replaced with good parts.
- ALWAYS use approved tire and rim combinations for the model scraper that you have and verify that part numbers of components are correctly matched for the assembly.
- ALWAYS exhaust all air from the tire prior to demounting.
- ALWAYS place wheel and tire assemblies in restraining devices (safety cage) when inflating tires. Use a clip-on chuck and long extension hose to allow you to stand to the side of the tire and not in front of it.
- NEVER weld or cut on an inflated tire assembly. Welding heat can cause increased pressure which could result in tire explosion.
- ALWAYS use proper lifting techniques, and mechanized lifting aids to move heavy components and assemblies.
- NEVER leave a tire, wheel, or assembly unsecured in a vertical position.
- ALWAYS take care when moving tires and wheels that other people in the area are not endangered.

ASHLAND SCRAPERS
Tire Inflation & Torque Charts

TIRE INFLATION (PSI)				
Scraper Model	Front Tire Size (XL)	Max PSI	Rear Tire Size	Max PSI
950	16.5-16.1 ANS 10 Ply	36	16.9-24 ANS 8 Ply	24
110	16.5L-16.1 ANS 10 ply	36	18.4-26 ANS 10 Ply	26
130	21.5-15.1 10 Ply	28	18.4-26 ANS 12 Ply	32
155	20.5-25 12 Ply	51	29.5 X 25 28 Ply	62
175	20.5-25 12 Ply	51	29.5 X 25 28 Ply	62
180TS			29.5 X 25 28 Ply	62
180CS			23.5 X 25 12 Ply	54
200			20.5-25 12 Ply	65

On new machines, the wheels should be retorqued after the first two hours of use. Then check tires daily to ensure correct inflation levels. Check tire pressure with an accurate gauge having 6.9 kPa (0.07 bar) 1 psi) gradations.

Check tires daily to ensure correct inflation levels. Also check for:

- Tire Damage
- Loose or missing wheel lugs, nuts or caps
- Uneven wear
- Damaged Rims

Torque Ft-lbs	Lug nuts (by model)
85-100	900-950
450	110-130
450	155-175 front
750	155-175 rear
450-500	180TS-180CS
750	200
Torque Ft-lbs	Bolt Diameter
12	¼"
25	5/16"
45	3/8"
70	7/16"
110	½"
150	9/16"
220	5/8"
380	¾"
600	7/8"



PUSHING THE EARTHMOVER

This scraper was designed to be pushed when equipped with the optional push-bar. However, Ashland Industries, Inc. **STRONGLY** recommends using extreme caution when pushing the earthmover to prevent any unnecessary damage.

CAUTION! The earthmover must be pushed in a straight line with a maximum of a 100 hp dozer. Do not ram or jar the earthmover while pushing and push at a constant speed.

Introduction

With proper care and maintenance, your Ashland Scraper will give many years of reliable service. When a situation arises where the earthmover performance is not satisfactory, this section will give some pointers on finding and correcting the problem.

Grease zerk will not take grease.

1. Grease zerk plugged.
 - a) Remove and replace grease zerk.
 2. Pin is frozen.
 - a) Remove, clean, and inspect pin.
 - b) Replace pin if necessary.
 3. Bushing grease passage is not aligned with grease zerk.
 - a) Remove, clean, inspect, and realign bushing.
 - b) Replace bushing if necessary and realign.
-

Push-off rollers do not roll.

1. The rollers need lubrication.
 - a) Check zerk hole and grease.
 - b) Remove pin, clean, inspect, and replace if necessary.
 2. The roller bushing is worn out.
 - a) Remove roller assembly and replace bushing.
 - b) See parts manual.
-

Cylinders will not hold in preset position, i.e. the cylinder creeps.

1. Seals leaking internally.
 - a) Remove and replace seal kit.
-

Machine cuts unevenly.

1. Cutting edges worn unevenly.
 - a) Replace cutting edges.
 2. Improperly inflated tires.
 - a) Check air pressure in tires.
-

Limited Warranty Statement

Ashland Industries Inc. warrants each new product to be free from defects in material and workmanship. This warranty is applicable only for the normal service life expectancy of the product or components, not to exceed **six consecutive months** from the date of delivery of the new Ashland Industries product to the purchaser, or the date the product is first put into service via a rental agreement or other means, whichever occurs first.

The major components of swivel hitches used on Industrial series scrapers are warranted for three consecutive months from the date of delivery of the new Ashland Industries product to the purchaser, or the date the product is first put into service via a rental agreement or other means, whichever occurs first, except those components described below.

Genuine Ashland Industries Inc. replacement parts and components will be warranted for 30 days from date of purchase, or the remainder of the original equipment warranty period, whichever is longer.

Under no circumstances will it cover any merchandise or components thereof, which in the opinion of the company, has been subjected to misuse, unauthorized modification, alterations, an accident or if repairs have been made with parts other than those obtained through Ashland Industries Inc.

Ashland Industries Inc. in no way warrants Tires since their respective manufacturer warrants these items separately. Please call Ashland Industries Inc. to receive phone numbers of tire suppliers.

Ashland Industries Inc. in no way warrants wearable items such as cutting edges, front dolly wheel balls, socket halves, rollers, bushings, yoke hitch pins, hitch bushings, etc..

Our obligation under this warranty shall be limited to repairing or replacing, free of charge to the original purchaser, any part that, in our judgment, shall show evidence of such defect, provided further that such part shall be returned within 30 days from the date of failure to Ashland Industries Inc. routed through the dealer and distributor from whom the purchase was made, transportation charges prepaid. Upon warranty approval proper credits will be reimbursed for transportation.

This warranty shall not be interpreted to render Ashland Industries Inc. liable for injury or damages of any kind or nature to person or property. This warranty does not extend to the loss revenue, extra labor cost associated with downtime, substitute machinery, rental or for any other reason.

Except as set forth above, Ashland Industries Inc. shall have no obligation or liability of any kind on account of any of its equipment and shall not be liable for special or consequential damages. Ashland Industries Inc. make no other warranty, expressed or implied, and, specifically, Ashland Industries Inc. disclaims any implied warrant or merchantability or fitness for a particular purpose. Some states or provinces do not permit limitations or exclusions of implied warranties or incidental or consequential damages, so the limitations or exclusion in this warranty may not apply.

This warranty is subject to any existing conditions of supply which may direct affect our ability to obtain materials or manufacture replacement parts.

Ashland Industries Inc. reserves the right to make improvements in design or changes in specifications at any time, without incurring any obligation to owners of units previously sold.

No one is authorized to alter, Modify or enlarge this warranty nor the exclusion, limitations and reservations.

Ashland Industries Inc.
Warranty Department