

# *Ashland*

## EARTHMOVERS



# I-130XL2

## PARTS MANUAL

ver 0110



Ashland Industries Inc.  
1115 Rail Drive  
P.O. Box 717  
Ashland, WI. 54806  
Ph: 877-634-4622 Toll Free  
Ph: 715-682-4622  
Fx: 715-682-9717  
[www.ashlandind.com](http://www.ashlandind.com)

MEMBER



CONSTRUCTION INDUSTRY  
MANUFACTURERS ASSOCIATION



# I-130 XL2

## How to Order Parts



## HOW TO ORDER PARTS:

### IMPORTANT

Parts must be ordered through your local authorized ASHLAND dealer.

Be sure to state MODEL and SERIAL NUMBER of your machine, PART NUMBER, DESCRIPTION and QUANTITY needed.



Unless this is done, we cannot provide prompt service or assure shipment of the correct parts.

Ashland Industries weldable replacement parts are available to rebuild, modify or update your scraper to current factory specifications.

## Index

Page 1.	Index
Page 2.	Safety Guidelines
Page 3.	Operators and Maintenance Instructions
Page 4.	Assembly – Illustration and Parts
Page 5.	Gooseneck Frame Assembly – Illustration and Parts
Page 6.	Apron Assembly – Illustrations and Parts
Page 7.	Bowl and Frame Assembly – Illustration and Parts
Page 8.	Push Off Gate Assembly – Illustration and Parts
Page 9.	Pole and Axle Assembly – Illustration and Parts
Page 10.	Front Wheel and Hub Assembly – Illustration and Parts
Page 11.	Rear Wheel, Spindle and Hub Assembly – Illustration and Parts
Page 12.	Hydraulic Cylinder, 4" X 13" (Apron) – Illustration and Parts
Page 13.	Hydraulic Cylinder 5" X 16" (Dig & Lift)– Illustration and Parts
Page 14.	Hydraulic Cylinder 4 ½" X 54" (Pushgate)
Page 15-17.	Identification, Illustration, Parts List and Adjustment – Hydraulic Valve
Page 18-21.	Hydraulics
Page 22-26.	Service Manual Appendix
Page 27.	Troubleshooting
Page 28.	Warranty Statement

# I-130 XL2

## Safety Guidelines



### SAFETY SIGNAL WORDS

Note the use of the signal words **DANGER**, **WARNING** and **CAUTION** with the safety messages. The appropriate signal word for each has been selected using the following guidelines:



**DANGER:** Indicates an imminently hazardous situation that, if not avoided, will result in death or serious injury.

This signal word is to be limited to the most extreme situations typically for machine components which, for functional purposes, cannot be guarded.



**WARNING:** Indicates a potentially hazardous situation that, if not avoided, could result in death or serious injury, and includes hazards that are exposed when guards are removed. It may also be used to alert against unsafe practices.



**CAUTION:** Indicates a potentially hazardous situation that, if not avoided, may result in minor or moderate injury. It may also be used to alert against unsafe practices.



### GENERAL SAFETY GUIDELINES

Safety of the operator is one of the main concerns in designing and developing a new piece of equipment. Designers and manufacturers build in as many safety features as possible. However, every year many accidents occur which could have been avoided by a few seconds of thought and a more careful approach to handling equipment. You, the operator, can avoid many accidents by observing the following precautions in this section. To avoid personal injury, study the following precautions and insist those working with you, or for you, follow them.

Replace any **CAUTION**, **WARNING**, **DANGER** or instruction safety decal that is not readable or is missing. Location of such decals is indicated in this booklet.

Do not attempt to operate this equipment under the influence of drugs or alcohol.

Review the safety instructions with all users annually.

This equipment is dangerous to children and persons unfamiliar with its operation. The operator should be a responsible adult familiar with farm machinery and trained in this equipment's operations. **Do not allow persons to operate or assemble this unit until they have read this manual and have developed a thorough understanding of the safety precautions and of how it works.**

To prevent injury or death, use a tractor equipped with a Roll Over Protective System (ROPS). Do not paint over, remove or deface any safety signs or warning decals on your equipment. Observe all safety signs and practice the instructions on them.

Never exceed the limits of a piece of machinery. If its ability to do a job, or to do so safely, is in question - **DON'T TRY IT.**

## OPERATORS AND MAINTENANCE INSTRUCTIONS

This scraper is a durable piece of equipment and with proper care will yield many years of trouble free operation. The scraper requires a power source with TWO 4 way (double acting) hydraulic control valves.

The scraper should be greased at all points where grease fittings are provided. Connect hydraulic hoses to the tractor and retract lift cylinders to **REMOVE TRANSPORT LOCK PINS** (point A), then extend and retract all cylinders several times to force out any air from the hydraulic cylinders and lines. Check the oil levels in the tractor hydraulic system and add to maintain the proper level. Care should be used when adding oil or when disconnecting any oil line to keep all dirt out of the oil as dirt is a major factor in the failure of hydraulic components.

When the scraper is placed into operation, the operator will have to "feel out" the amount of depth of cut to obtain maximum loading efficiency. This is usually accomplished by taking a lesser and more uniform cut; however, some soil conditions such as loose sand may require a "pumping action" obtained by taking successive deep cuts and lifting out of cut as the tractor begins to lose power or traction.

1. After 10 hours work, all bolts should be checked and tightened if necessary.
2. Every 10 hours all grease fittings should be lubricated.
3. After 50 hours work, all bolts should be rechecked and tightened if necessary. Check wheel bearings and adjust if necessary.
4. After 300 hours work, clean and repack wheel bearings and replace, if necessary, cutting edges, worn pins, etc.

# I-130 XL2

## Assembly Illustration

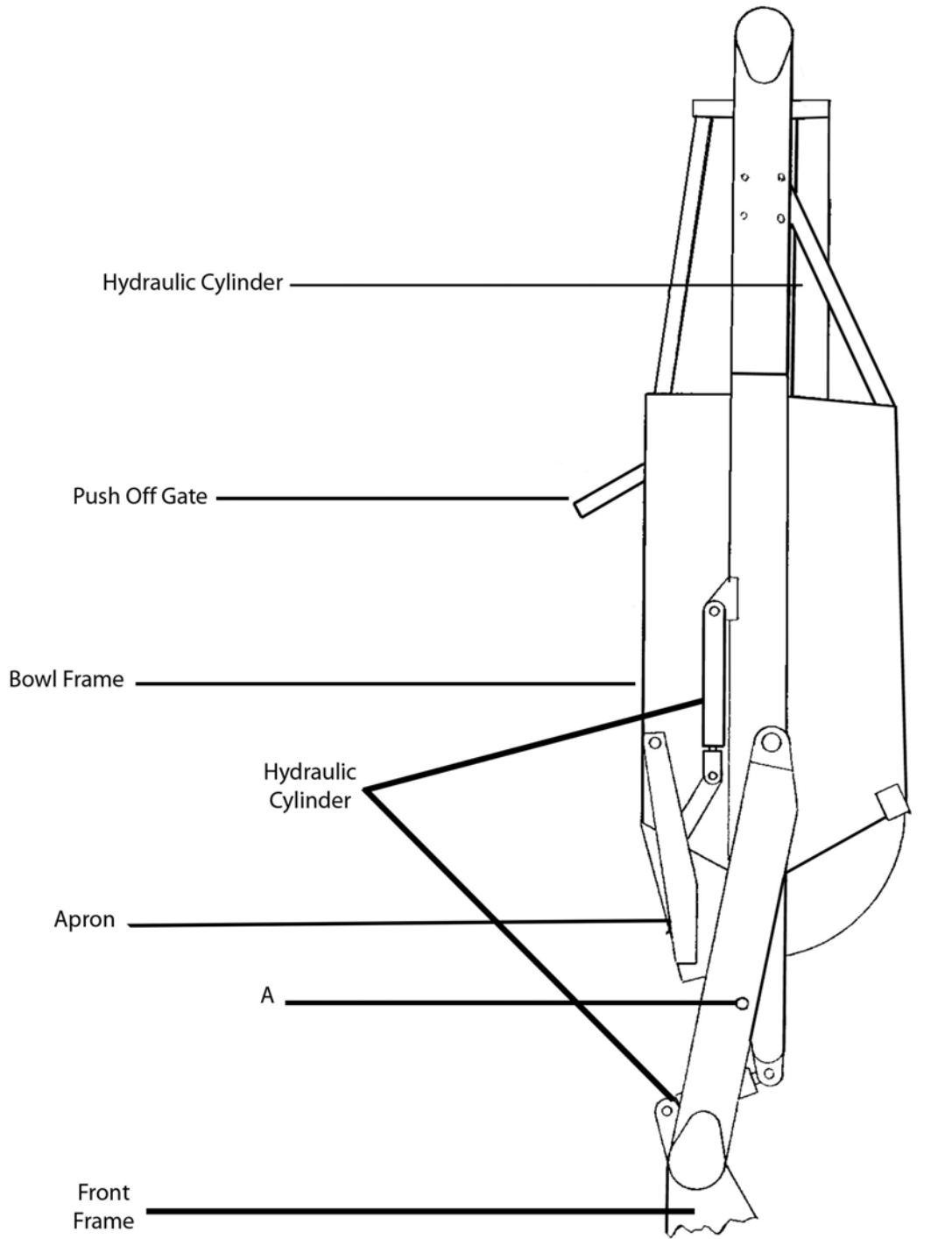

I-Series Assembly-ILL

# I-130 XL2

## Gooseneck Frame Assembly

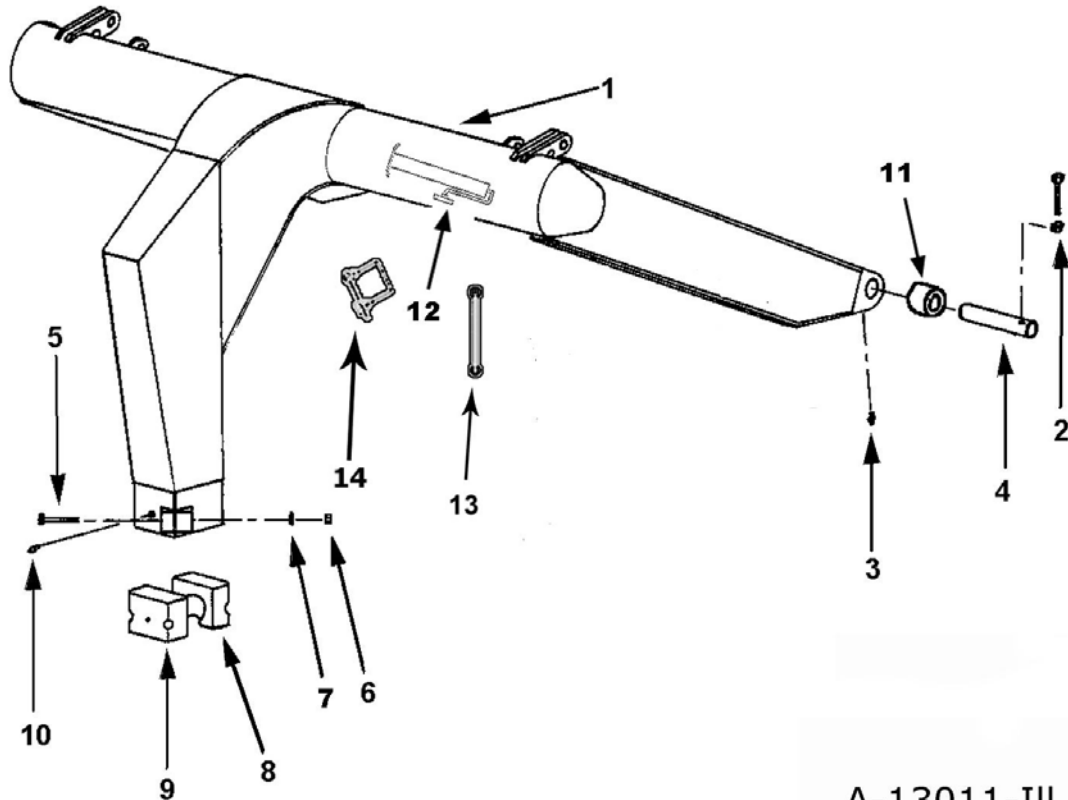

A-13011-III

Key Number	Part Number	Description
1	A13011	Gooseneck frame
2	AFB-00054	"Bolt, 1/2" NC x 3-1/2" w/ 7500 nut"
3	AHF-00028	Greasefitting 90° 1/8 NPT
4	A10152A	"Pin, Frame attachment, 2" OD x 8-1/16" Long"
5	AFB-00081	Bolt, 7/8" NF X 5" NF
6	7597	Nut, 7/8" NF
7	8125	"Lockwasher, 7/8"
8	A14002	"Cast socket half, rear"
9	A14003	"Cast socket half, front w/ zerk hole"
10	A2206	"Grease zerk, long shank"
11	A14039	"Bushing, 2.375 OD x 2.00 ID x 2" Long, grease Passage"
12	OPT-00001	Hitch jack
13	A030672-33	Dog Bone
14	A125006	Safety Snap Pin

# I-130 XL2

## Apron Assembly I-130XL2

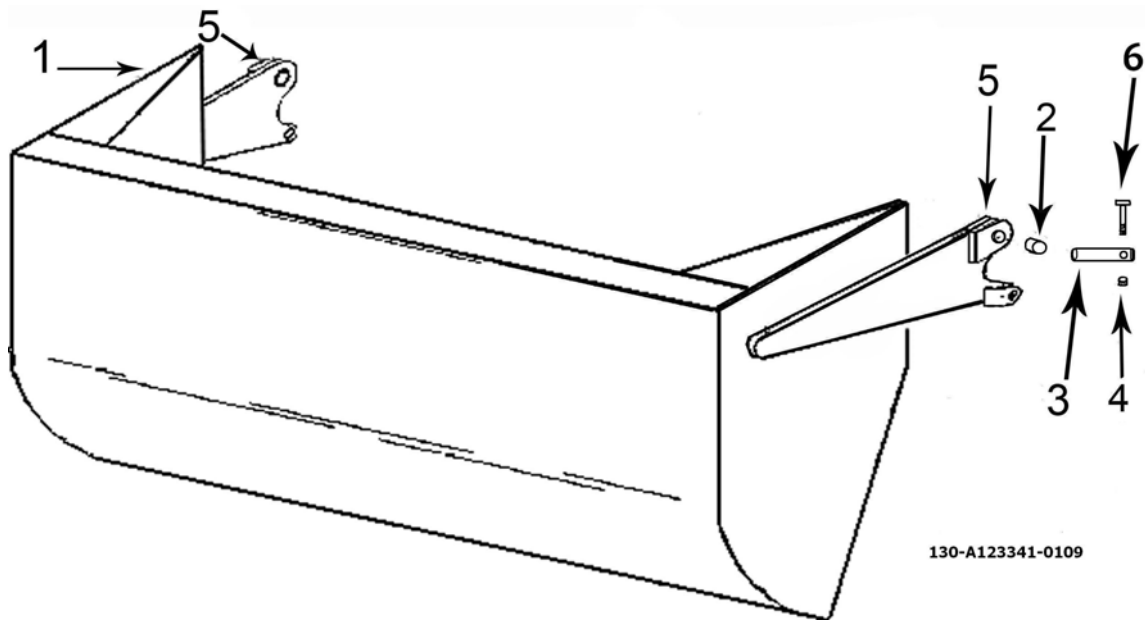

Key Number	Part Number	Description
1	A123341	Apron
2	A123343	Bushing: 2" OD X 1 1/2 ID X 1 3/4L
3	A123337	Pin: 1 1/2" X 5 3/8" L
4	7450	Nut: 3/8 NC
5	14505	Grease Fitting
6	AFB-00049	Bolt: 3/8 NC X 3"

# I-130 XL2

## Bowl & Frame Assembly

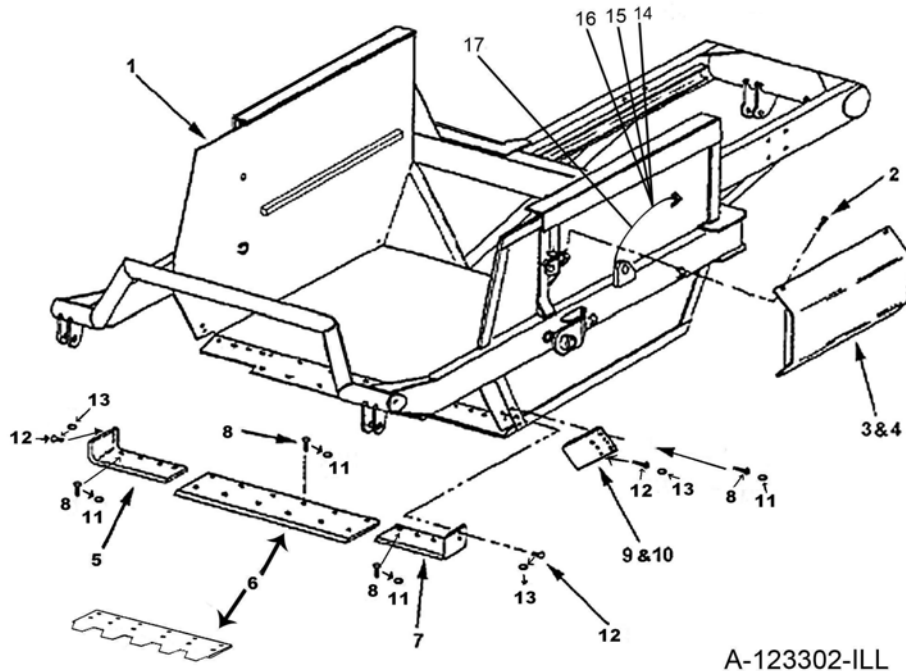

**Blade Bolts Required:**

		<u>Qty</u>
A123331 (& Ser)	PB9P-NC-088-0275	(12)
A123332L & R	PB9P-NC-088-0275	(4)
	PB9P-NC-088-0225	(2)
A123338L & R	PB9P-NC-088-0275	(4)
	PB9P-NC-088-0225	(3)

Key Number	Part Number	Description
1	A123164	Bowl & Frame I-130 XL2
2	AFB-00094	Flange Bolt 3/8 NC X 1
3	A123309-62L	Cylinder Guard - Left Hand
4	A123309-62R	Cylinder Guard - Right Hand
5	A123332R	Right Cutting Edge, 8" x 22-1/2" x 7/8" Hardened
6	A123331	Center Cutting Edge, 13" X 54" Hardened
	A123331-SER	Optional Center Cutting Edge, serrated, 13" X 54", Hardened
7	A123332L	Left Cutting Edge, 8" x 22-1/2" x 7/8" Hardened
8	PB9P-NC-088-0275	Plow Bolt, 7/8" NC x 2-3/4"
9	A123338L	(Optional) Left Bank Shaver Side Blade, 7/8" holes
10	A123338R	(Optional) Right Bank Shaver Side Blade, 7/8" holes
11	AFN-00019	Nut: 7/8" NC
12	PB9P-NC-088-0225	Plow Bolt, 7/8" NC X 2 1/4"
13	AFN--00026	7/8" Jam Nut
14	A12019	Grease fitting 1/4 x 28.54 Long
15	A125026	Bulkhead Nut
16	A123309-89	Single Hole Tab
17	A125022	18" Grease Line



# I-130 XL2

## Push Off Gate Assembly 130XL2

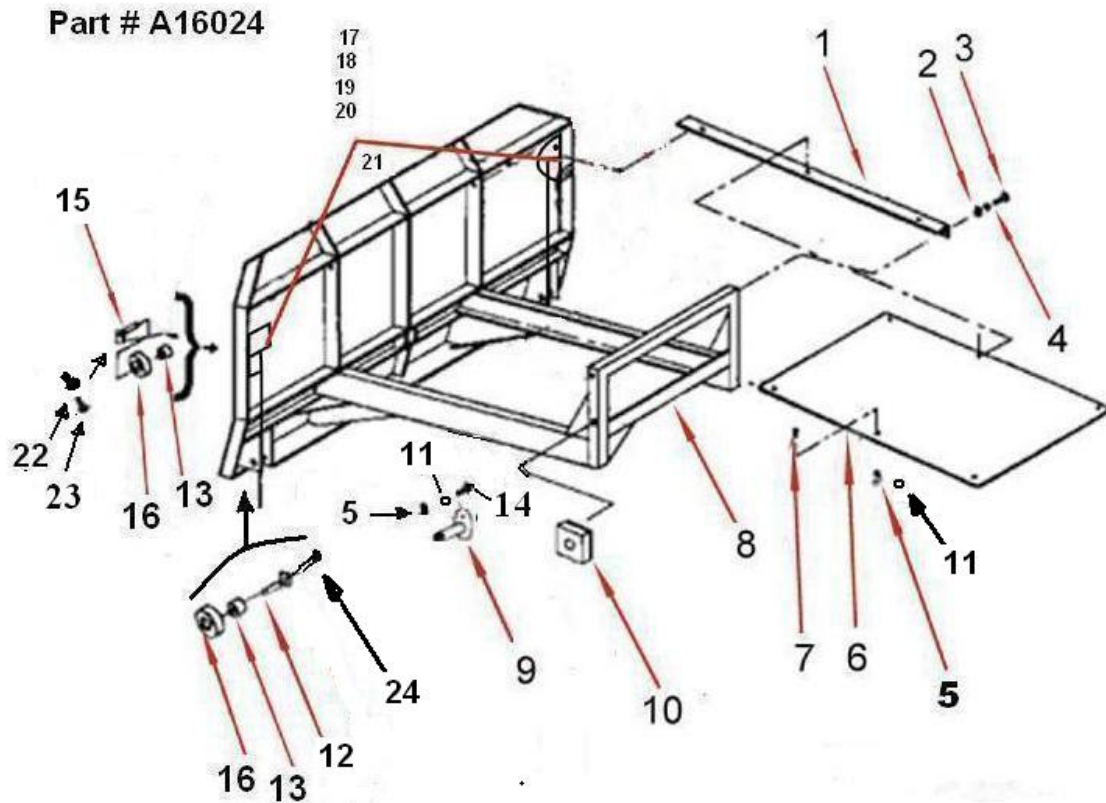

130X-A16024-22128

Key Number	Part Number	Description
1	A10159	Brace (L.H. & R.H. same)
2	AFN-00006	Nut: 3/4" NC
3	AFB-00037	Bolt: 3/4" NC X 2" Lg.
4	AFW-00002	Lockwasher: 3/4"
5	7500	Nut: 1/2" nc
6	A10171	Dirt Shield
7	AFB-00019	Bolt: 1/2" X 1/2" NC
8	A16024	Push Off Gate: Model 130
9	A123305A	Pin: 1 1/4" X 2 3/4"
10	A123353	Wear Pad
11	8100	Lockwasher: 1/2"
12	A123323-21	Pin: Lower Roller 1 1/4" X 5 1/4"
13	A10163	Bushing: 1 3/4" OD X 1 1/4" ID
14	AFB-00033	Bolt: 1/2 NC X 2 1/2"
15	500465	Pin: 1 1/4" X 7"
16	A10164	Roller: 4 1/4" OD X 1 3/4" ID
17	A125020	32" grease line
18	A123323-40	Double Hole Tab
19	A125026	Bulkhead Nut
20	A125021	54" greaseline
21	A125019	Greasefitting 1/4-28 54" Long
22	A123358	Pin Keeper Bushing
23	AFB-00079	Bolt: 5/8" X 1 1/2" Gr. 8
24	AFP-00001	Cotter Pin: 1/4 X 3 1/2"

# I-130 XL2

## Pole & Axle Assembly

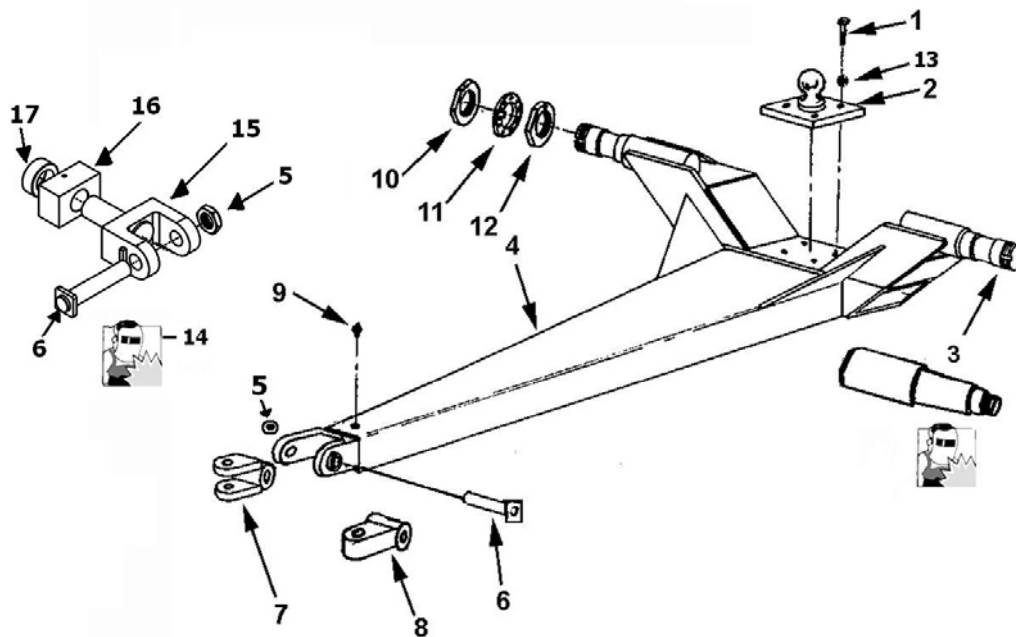

130X-A13006-22079

Key Number	Part Number	Description
1	AFB-00018	Bolt, 1" NC X 3" lg.
2	A14017	Ball Swivel
3	A14021	Spindle (weld on)
4	A13006	Pole
5	500462	Nut, Swivel Pin
6	600055	Pin, Swivel Hitch
7	A17511	Swivel hitch, double lip (optional)
8	A17510	Swivel hitch, single lip
9	14505	Grease fitting
10	A10048	Spindle Nut
11	A10049A	Lock collar
12	A10172	Nut w/lock pin
13	AFW-00006	Lockwasher, 1"
14	A123232A	Yoke hitch rebuild kit: (includes block, collar, yoke, pin, nut (5,6,15,16,17))
15	A123232-3	Swivel Yoke Assembly
16	A123232-2	Swivel Block
17	A123232-1A	Retaining Collar

# I-130 XL2

## Front Wheel & Hub Assembly

### FRONT WHEEL AND HUB ASSEMBLY

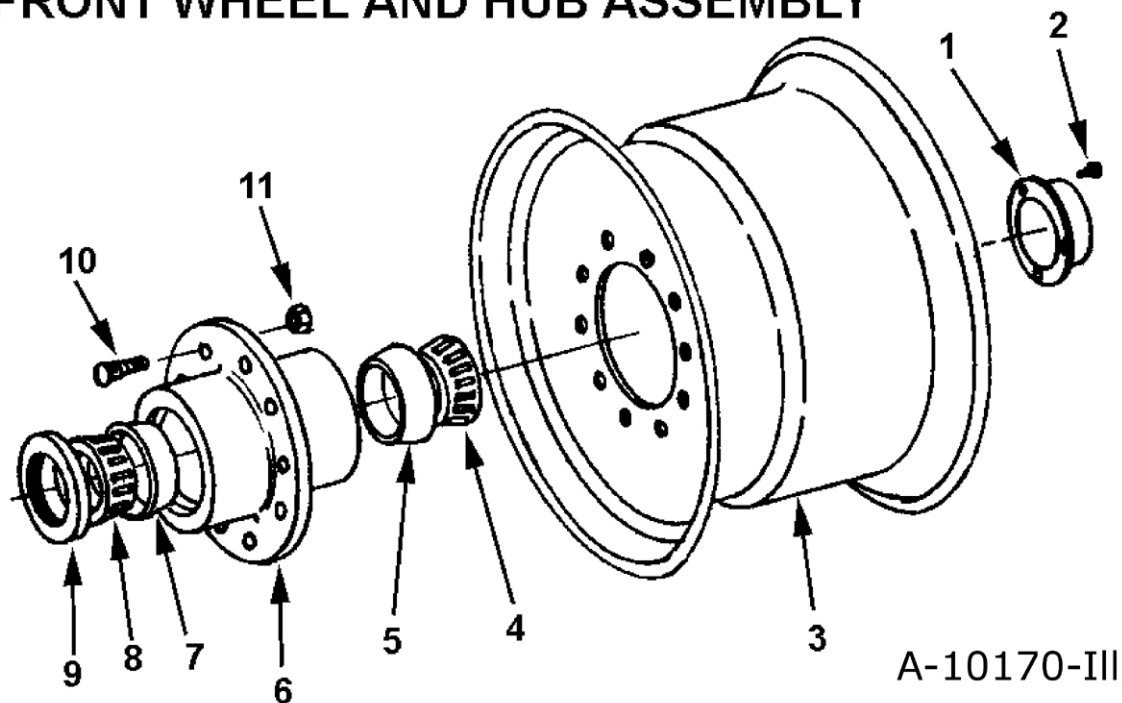

Key Number	Part Number	Description
1	A14004	Hub cap
2	AFB-00080	"Bolt, 5/16 NC x 1/2s lg.
3	A13007	Wheel, 18 x 16.1
4	A14015	Bearing cone
5	A14014	Bearing cup
6	A14010A	Hub
7	A14013	Bearing cup
8	A14012	Bearing cone
9	A14011	Grease seal
10	A10176	Stud
11	A10046	Lug nut

# I-130 XL2

## Rear Wheel Spindle & Hub Assembly

### REAR WHEEL, SPINDLE & HUB ASSEMBLY

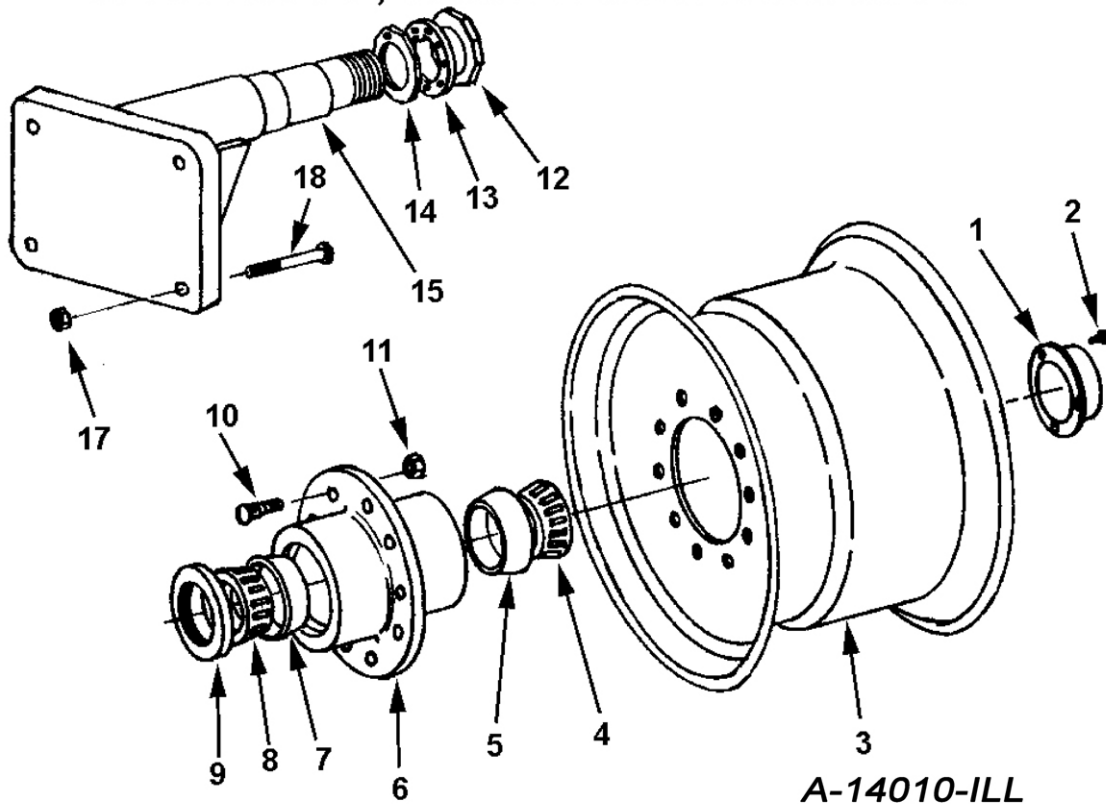

A-14010-ILL

Key Number	Part Number	Description
01	A14004	Hub cap
02	AFB-00080	"Bolt, 5/16 NC x 1/2 lg."
03	A10039	"Wheel, 16 x 26 Drop Center"
04	A14015	Bearing cone
05	A14014	Bearing cup
06	A14010A	Hub
07	A14013	Bearing cup
08	A14012	Bearing cone
09	A14011	Grease seal
10	A10176	Stud
11	A10046	Lug nut
12	A10048	Spindle nut
13	A10049A	Lock collar
14	A10172	Nut w/ lock pin
15	A14037	Spindle
17	AFN-00001	"Nut, 1" NF Top Lock"
18	AFB-00017	"Bolt, 1" NF x 6-1/2" lg."

# I-130 XL2

## Apron Cylinder 4" x 13" Part # A125050

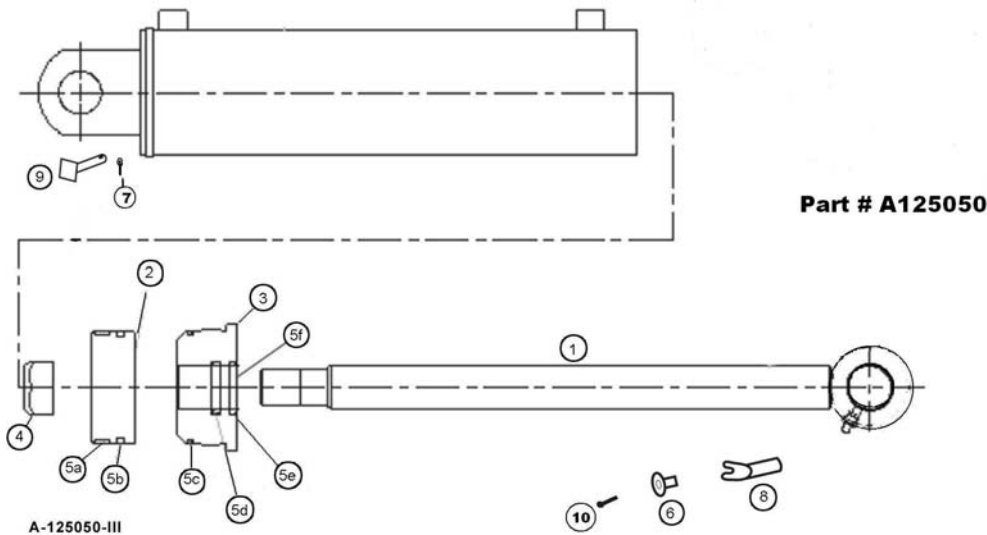

Key Number	Part Number	Description
1	A125050	Apron Cylinder 4" X 13"
2	A125050-01	Rod 1-3/4" with welded eye
3	A125050-02	Piston
4	A125050-03	"Gland, Threaded "
5	A125050-04	"Lock Nut, 1-1/8" NF"
6	A125050-05	"Seal Kit, a-f"
a	A125050-05a	Nylon Wear Ring
b	A125050-05b	FSP Seal
c	A125050-05c	O-Ring
d	A125050-05d	Backup Washer
e	A125050-05e	Hallite Rod Seal
f	A125050-05f	Snap-in Rod Wiper
7	A123351	Flange Bushing
8	8602	"Pin, Cotter 1/4" x 2" Zinc"
9	A123363	Pin: 1-1/2" square head
10	A123362	Pin 1 1/2" with Slot for Pin Keeper
11	AFB-00015	1/2" X 1 1/2" Gr 8 Bolt

# I-130 XL2

## Hydraulic Cylinder Dig and Lift

Part # A516H114A

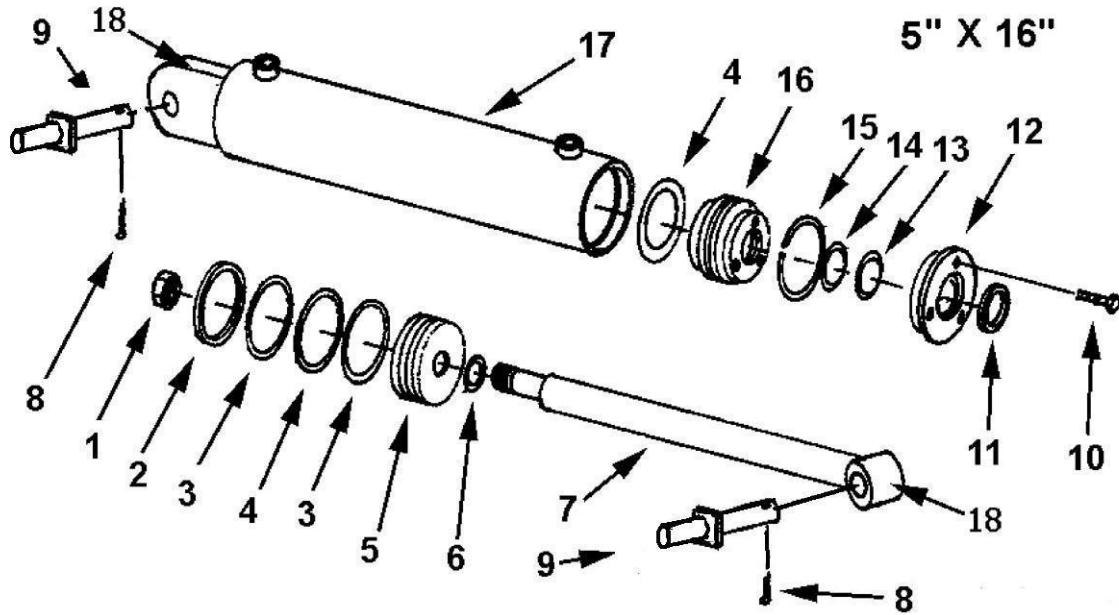

A-130H27-III

Key Number	Part Number	Description
1	A400H17	"Lock nut, 1-1/4" NF"
2	A400H04	"Cast iron ring, 5" OD"
3	A400H05	"Backup washer, 5" OD"
4	A400H06	"O-ring, 5" OD x 1/4"
5	A400H07	"Piston, 5" OD"
6	A60H52	"O-ring, 1-1/4" ID x 1/8"
7	A130H28	"Shaft, 2" dia."
8	8602	"Cotter pin, 1/4" x 2"
9	A123383	"Pin, 1-1/4" x 7"
10	22H18A	"Capscrew, 5/16" NC x 1"
11	A400H14	Wiper seal
12	A400H13	Head cap
13	A400H12	"O-ring, 2" ID"
14	A400H12A	"Backup washer, 2" ID"
15	A400H11	Retainer ring
16	A400H10	"Head gland, 5" OD"
17	A130H27	"Barrel Assembly, 5" ID"
18	14505	Grease fitting
	A400H15C	Packing Kit containing: (1) A400H04, (2) A400H05, (2) A400H06, (1) A60H52, (1) A400H11, (1) A400H14, (1) A400H12, (1) A400H12A

# I-130 XL2

## Pushgate Cylinder

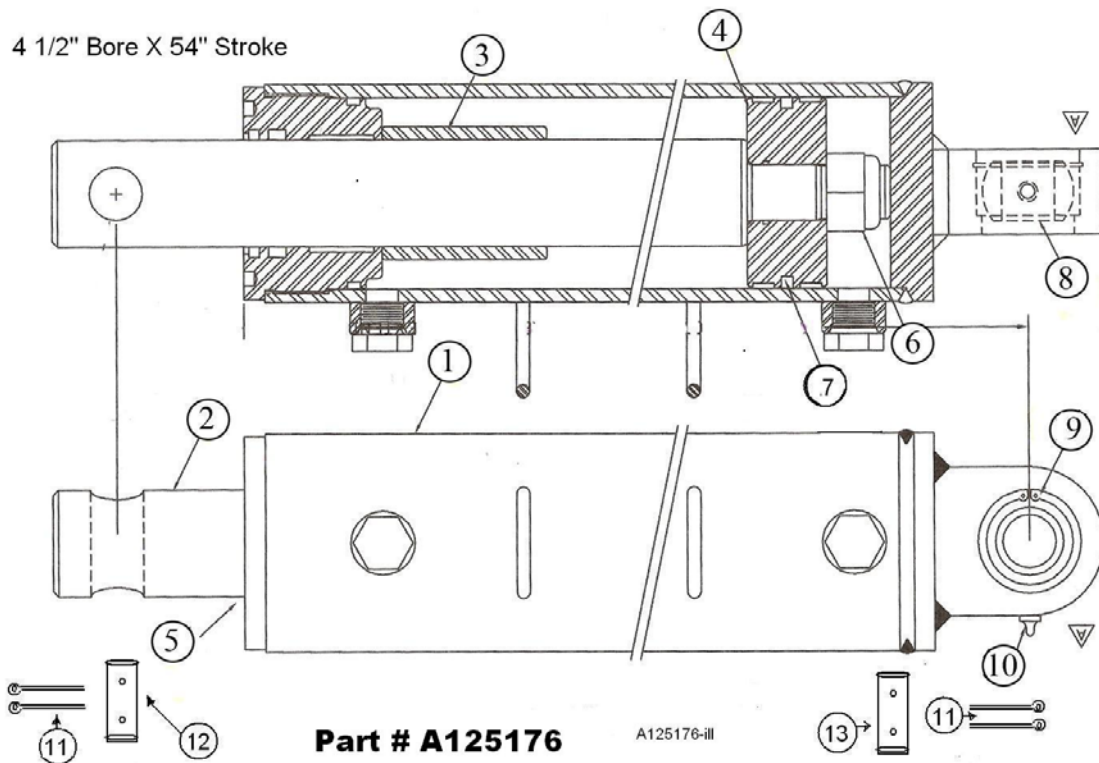

Key Number	Part Number	Description
	A125176	Pushgate Cylinder
1	A125176-10	Barrel Weldment
2	A125176-20	Shaft
3	A125176-32	Spacer
4	A125176-30	Piston
5	A125176-31	Head
6	A125175-33	1 1/4" Nylock Nut
7	A125176-40	Seal Kit
8	A125175-35	Bearing
9	A125175-36	Snap Ring
10	A125175-37	Grease Zerk
11	8602	1/4" X 2" Cotter Pin
12	A14033	Pin Rod End
13	A9024	Pin Barrel End

# I-130 XL2

## Hydraulic Manifold Assembly

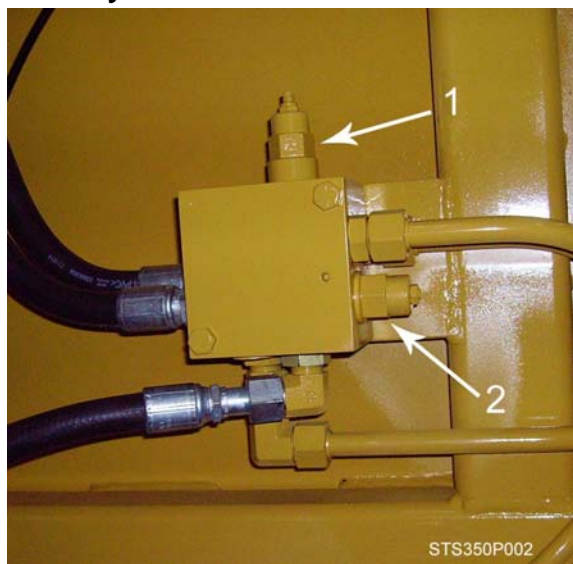

**IMPORTANT:** This Hyd. Manifold was integrated into production April, 2006 It replaces A125070 valve.

For older machines see master parts book on Ashlandind.com.

### HYDRAULIC MANIFOLD ASSEMBLY

#### A125174

### SETTING THE APRON AND PUSHOFF VALVE

The manifold block containing the pushoff sequence valve cartridge and apron sequence valve cartridge is used to control two hydraulic circuits with one hydraulic remote. When the tractor hydraulic remote is activated, oil flows first to the apron cylinders until they are fully extended. Once the cylinders are fully extended, the apron circuits' hydraulic pressure begins to increase. Once the pressure threshold is surpassed (which is adjustable. See adjustment section), the sequence valve diverts the oil flow to the pushoff's hydraulic circuit. Once the push off is completely extended the operator then reverses the tractors hydraulic remote. The counterbalance valve will hold the apron open until the push off is fully retracted. The Apron sequence valve then opens and allows the apron to close.

#### Setting the valves:

##### STEP 1 PUSHOFF SEQUENCE VALVE

Loosen the lock nut (9/16") on the sequence valve cartridge. Turn the setscrew (4mm) clockwise until the front apron rises before the push-off begins to advance. (Earthmover should be empty) Turn the adjustment screw an additional 1/4 turn clockwise and tighten jam nut.

##### STEP 2 COUNTER BALANCE VALVE

Loosen the lock nut (9/16") on the counterbalance valve cartridge. Turn the setscrew (4mm) counter-clockwise until the apron holds in a raised position while rear gate is being retracted. Turn adjustment screw an additional 1/4 turn, tighten jam nut. DO NOT tighten adjusting screw more than necessary.

Key Number	Part Number	Description
1	A125162-02	PUSHOFF SEQUENCE CARTRIDGE
2	A125162-01	COUNTER BALANCE CARTRIDGE



# I-130 XL2

## Hydraulic Valve Assembly Ports

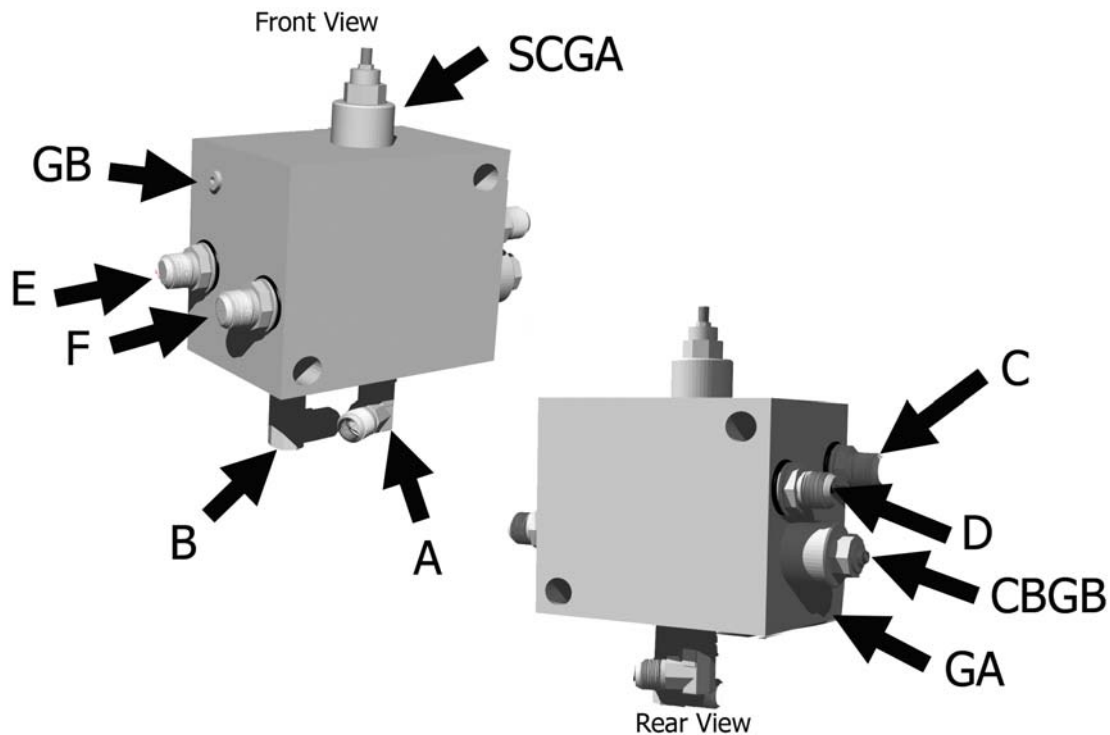

ILL. A125174 Port Location

Key Number	Description
A	Supply Line
B	Pushoff Cyl. (Rod End) - Apron Cyl., Right side (Rod End)-Supply Line
C	Pushoff Cylinder, (Base end)
D	Apron Cylinder, Right side, (Base end)
E	Apron Cylinder, Left side, (Rod end)
F	Apron Cylinder, Left side (Base end)
CBGB	Counterbalance Valve, adjustable
SCGA	Sequence Valve, adjustable
GA	Pressure test port
GB	Pressure test port

# I-130 XL2

## Hydraulic Valve Seals

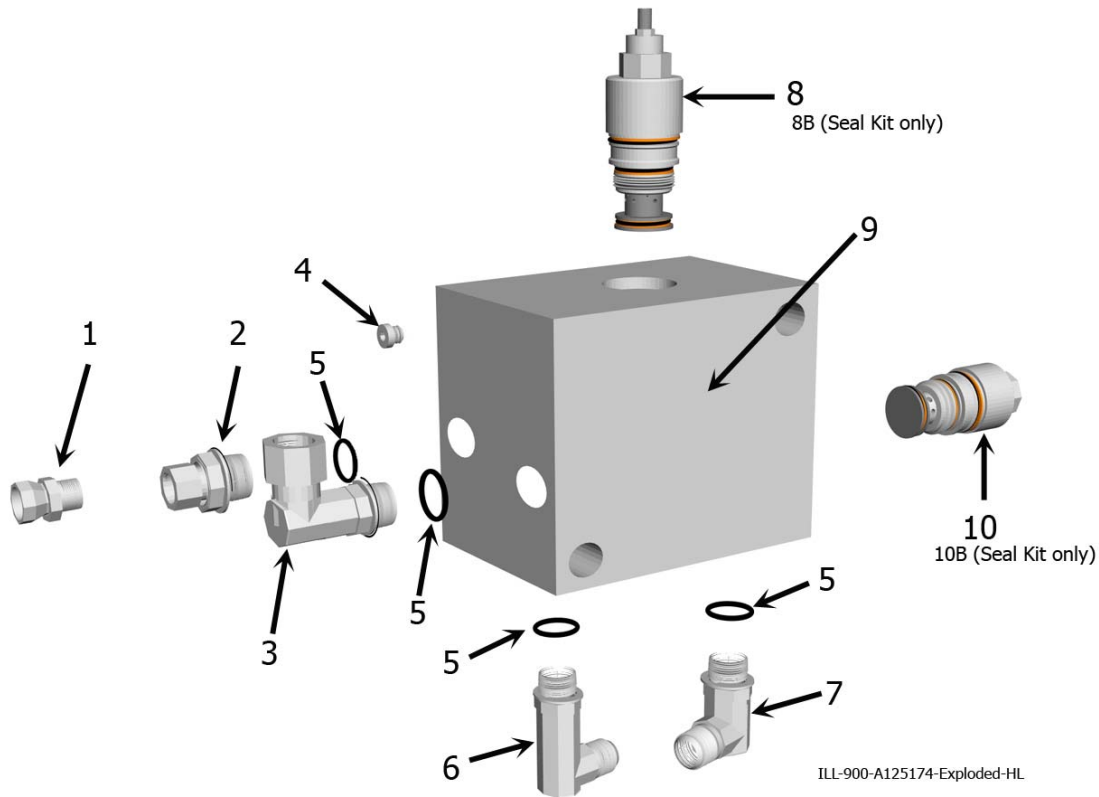

<u>ITEM</u>	<u>PART NO.</u>	<u>DESCRIPTION</u>
1	AHA-00076	Adapter: Str. Swiv 1/2 MP X 1/2 FP. 109 Rest
2	AHA-00043	Adapter: Str. Sw. 1 1/16 M ORB X 1/2 FP
3	AHA-00048	Adapter: 90 Deg. Swiv. 1 1/16 M ORB X 1/2 FP
4	AHA-00046	6 ORB Plug
5	AHS-00153	O-ring for 12 M ORB Fitting
6	AHA-00047	Adapter: 90 Deg. XL 3/4 MJ X 1 1/16 M ORB
7	AHA-00044	Adapter: 90 Deg. 3/4 MJ X 1 1/6 M ORB
8	A125162-02	Valve: Sequence Cartridge for Ver. III & IV
9	A125174	Valve: Manifold Block IV Body
10	A125162-01	Valve: Counterbalance Cartridge for Ver. III & IV
Seal Kits:	A125162-01KIT	Seal Kit for A125162-01 Valve Cartridge
	A125162-02KIT	Seal Kit for A125162-02 Valve Cartridge

# I-130 XL2

## Hydraulic Tubing Front

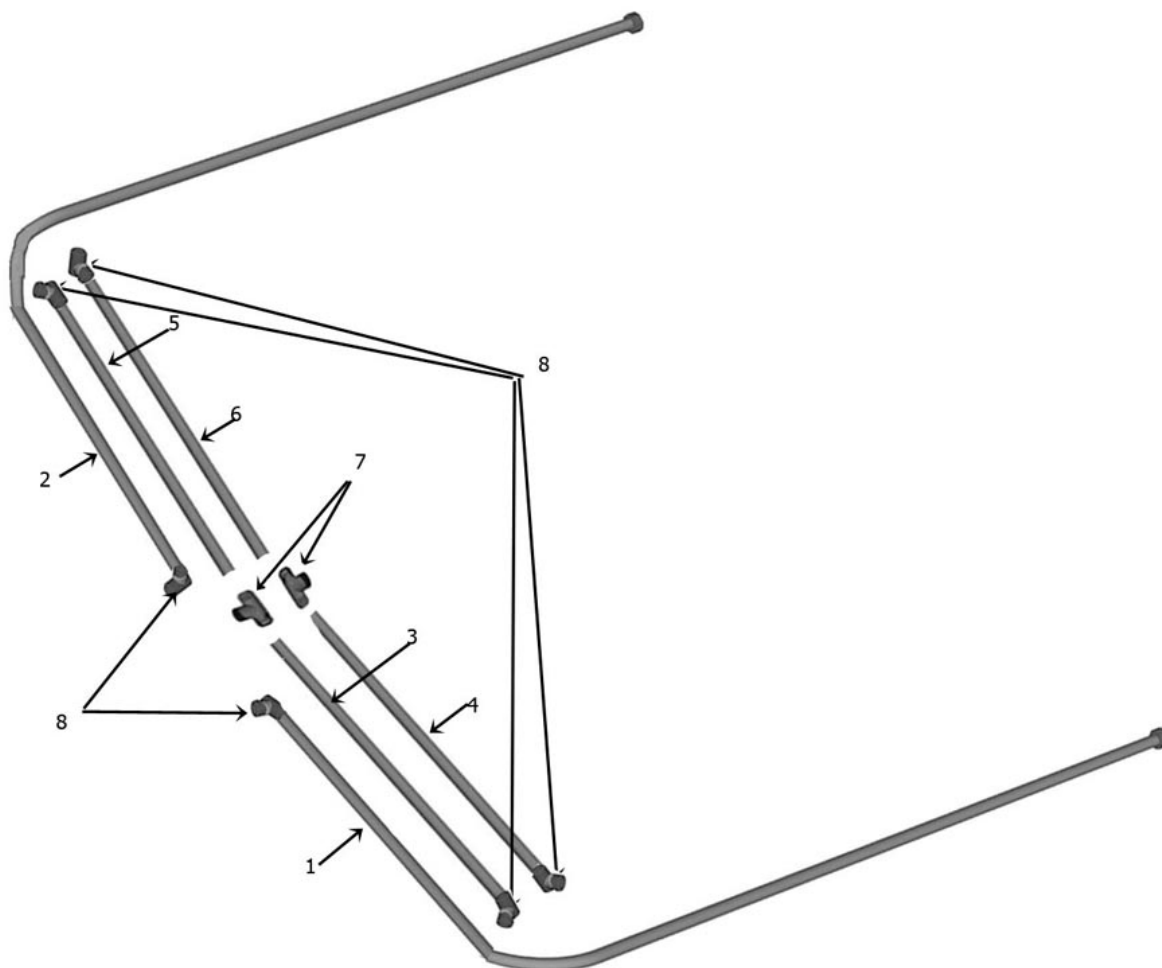

M130X400H003

Key Number	Part Number	Description
1	A123398	Tubing, Gooseneck Arm, Left Side
2	A123397	Tubing, Gooseneck Arm, Right Side
3	A123399	Tubing, Front Section Straight
4	A123400	Tubing, Front Section, Straight
5	A123400	Tubing, Front Section, Straight
6	A123399	Tubing, Front Section, Straight
7	AHA-00022	Adapter
8	AHA-00019	Adapter: 90 Deg.

# I-130 XL2

## Hydraulic Tubing Rear

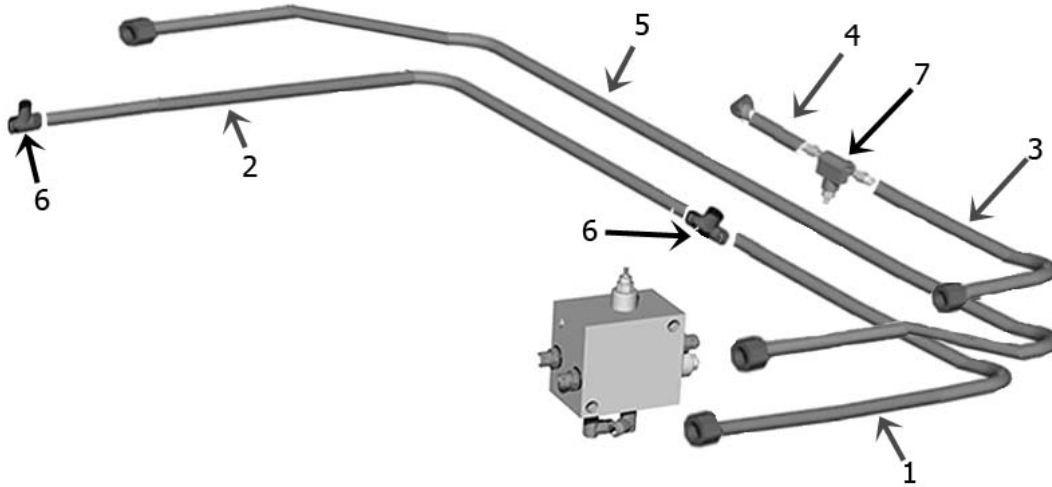

M130X400H002

Key Number	Part Number	Description
1	A123394	Tubing, Behind Bowl, Lower Left Side
2	A123392	Tubing Behind Bowl, Right Side
3	A123393	Tubing, Upper Left Side, Around Bowl
4	A123405	Tubing, Bowl, Rear Center
5	A123391	Tubing, Behind Bowl, Wrap Around Right & Left Sides
6	AHA-00022	Adapter
7	AHV-00001	Valve: Pressure Relief

# Hydraulic Plumbing Hoses

M130X400H005

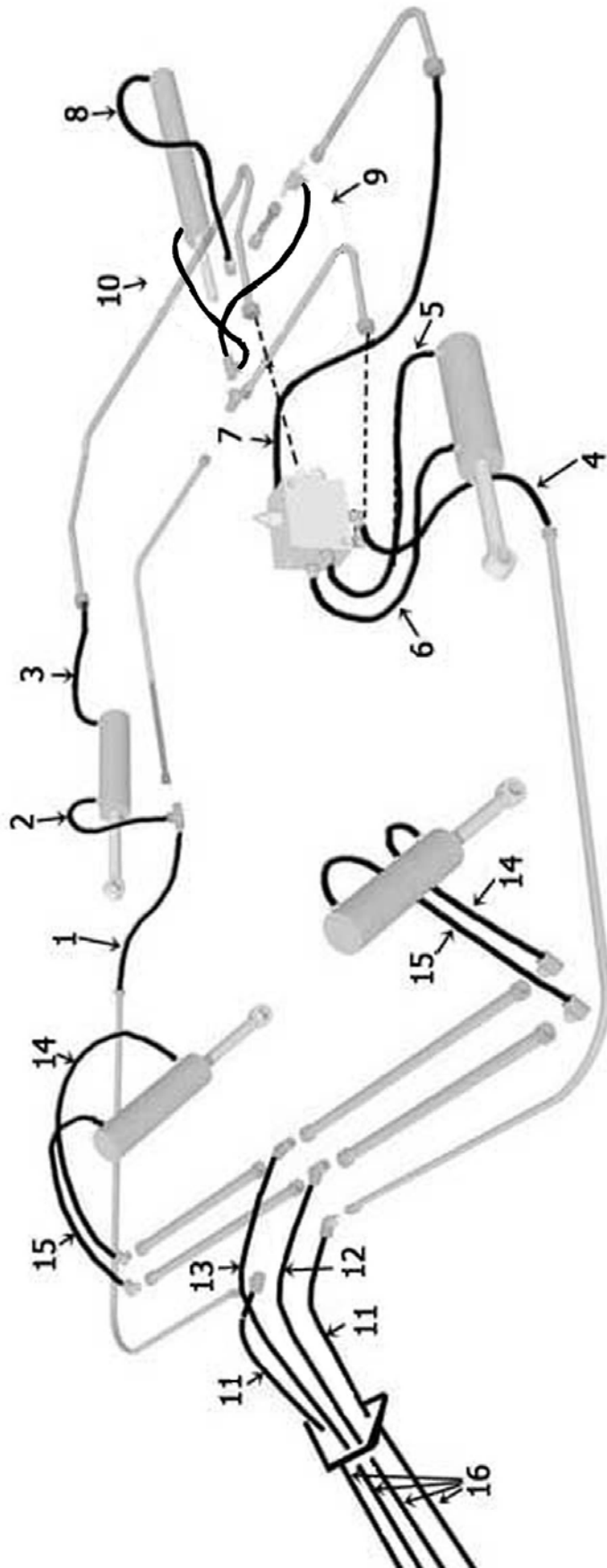

# I-130 XL2

## Hydraulic Plumbing Hoses

Key Number	Part Number	Description
1	A125274	Hose-R. Side Feed Line from "T" to Front Sect. - 50"
2	A125275	Hose-R. Side Apron Rod End to "T" - 50"
3	A125276	Hose-R. Side Apron Cyl. Barrel End to Inner Back Tube-25"
4	A125277	Hose-L. Side Feed Line "A" on valve to Front Sect. - 66"
5	A125278	Hose-L. Side Apron Cyl. Barrel End to "F" on Valve - 21"
6	A125279	Hose-L. Side Apron Rod End to "E" on Valve - 30"
7	A125280	Hose-L. Side From "C" on Valve to Top Outer Tubing - 17.5"
8	A125281	Hose-Rear top outer line to barrel end pushoff - 71"
9	A125282	Hose-Rear "T" to Pressure Relief Valve
10	A125283	Hose-Rear from Rod End of PUshoff to "T" Fitting - 16"
11	A125284	Hose-Front Bottom Inside Tube to Bottom L & R Bulkhead - 21"
12	A125285	Hose-Front Top Outer Tube to Center Left Bulkhead - 19"
13	A125286	Hose-Front top Inside Tube to Center Right Bulkhead - 22"
14	A125287	Hose-Front Top R & L Tube to Barrel End Lift Cyld. -24"
15	A125288	Hose-Front Inside Top R & L Tube to Rod End Lift Cyld. -50"
16	A125289	Hose-Front Connecting Hook-up Hoses to Bulkhead - 138"

# I-130 XL2

## Maintenance Checklist

# MAINTENANCE CHECKLIST

---

1. Grease all zerks.
  - a) Every 8 hours of operation.
  - b) See Lubrication Points section on next page.
  
2. Greasing the hubs.
  - a) Re-pack wheel bearings after 600 hrs of operation.
  - b) Completely clean grease out of hub and bearings every 1200 hours of operation.
  
3. Check tire pressure.
  - a) 20.5 - 25, 12-ply tire requires a tire pressure of 35-40 psi on a rear machine, 40-50 on a front machine.
  
4. Check all pins for signs of wear.
  - a) Daily
  
5. Check wheel lug nut torque.
  - a) After first 2 hours of operation.
  - b) Recheck daily for next 2 weeks.
  - c) Tighten wheel lug nuts in a star pattern.
  - d) Torque wheel lug nuts to 450 ft-lbs.
  
6. Check and retighten all bolts.
  - a) After initial 10 hours of use.
  - b) Again after 50 hours of use.
  - c) See Torque Specifications on next page.
  
7. Inspect cutting edges.
  - a) Daily
  - b) Replace cutting edges when center blade has been worn to approximately 6" and side edges worn to approximately 4".



**CAUTION!** Failure to replace worn cutting edges may result in unnecessary wear to the earthmover sides and floor.

Note: Please specify left or right "L" shaped cutting edges when ordering replacements.

# I-130 XL2

## Torque Specifications

### TORQUE SPECIFICATIONS

---

<i>Bolt Diameter</i>	<i>Torque Ft-lbs</i>
<i>1/4</i>	<i>12</i>
<i>5/16"</i>	<i>25</i>
<i>3/8"</i>	<i>45</i>
<i>7/16"</i>	<i>70</i>
<i>1/2"</i>	<i>110</i>
<i>9/16"</i>	<i>150</i>
<i>5/8"</i>	<i>220</i>
<i>3/4"</i>	<i>380</i>
<i>7/8"</i>	<i>600</i>
<i>1"</i>	<i>900</i>
<i>1-1/8"</i>	<i>1280</i>
<i>Lug Nuts</i>	<i>750</i>

### LUBRICATION

---

1. Grease all zerks every 8 hrs of operation with high quality, general-purpose grease.
  - a) Grease until grease flows from around pin.

#### Lubrication Points (see III.)

1. Hitch – Horizontal and vertical pins.
2. Lift Cylinders – Rod end & Trunion; Both left & right sides.
3. Front Arm Pivot Joint – Both left & right sides.
4. Apron Cylinders – Rod clevis pin; Both left & right sides.
5. Apron Pivot Pin – Both left & right sides.
6. Hold-down Rollers – Both left & right sides.
7. Floor Rollers – Both left & right sides.
8. Tapered Rollers – Both left & right sides.



# I-130 XL2

## Grease Locations

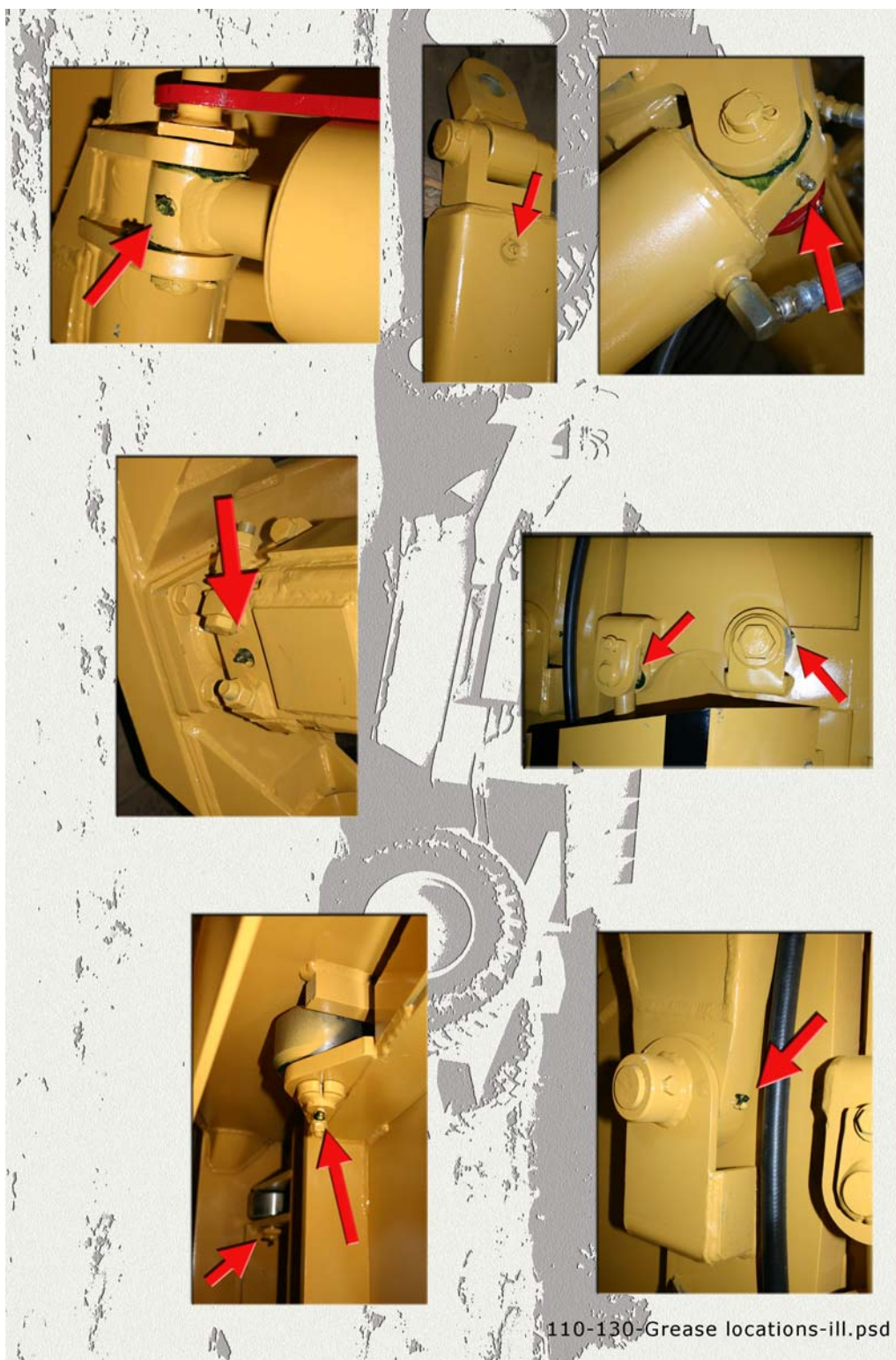

Part Number	Description
110-130-Grease locations-ill	Grease Twice a Day

## **I-130 XL2**

### **Hydraulic System**

#### **HYDRAULIC SYSTEM**

##### **Standard Two-Circuit Hydraulic Plumbing**

The apron cylinders and the push-off cylinder are controlled on the same circuit with the sequence of the operation controlled by a sequence valve. The other hydraulic circuit controls the lift cylinders on the earthmover.

- **To adjust the sequence valve, see Troubleshooting section.**

##### **Optional Three-Circuit Hydraulic Plumbing**

The apron cylinders, push-off cylinder, and lift cylinders are all on hydraulic circuits.

## I-130 XL2

### Pushing the Earthmover



#### **PUSHING THE EARTHMOVER**

---

The I-130XL2 was designed to be pushed when equipped with the optional push-bar. However, Ashland Industries, Inc. **STRONGLY** recommends using extreme caution when pushing the I-130XL2 earthmover to prevent any unnecessary damage.

**CAUTION!** The I-130XL2 earthmover must be pushed in a straight line with a maximum of a 100 hp dozer. Do not ram or jar the earthmover while pushing and push at a constant speed.

# I-130 XL2

## Troubleshooting

### TROUBLESHOOTING

---

#### Introduction

---

With proper care and maintenance, the I-110TS will give many years of reliable service. When a situation arises where the earthmover performance is not satisfactory, this section will give some pointers on finding and correcting the problem.

---

#### Grease zerk will not take grease.

---

1. Grease zerk plugged.
    - a) Remove and replace grease zerk.
  2. Pin is frozen.
    - a) Remove, clean, and inspect pin.
    - b) Replace pin if necessary.
  3. Bushing grease passage is not aligned with grease zerk.
    - a) Remove, clean, inspect, and realign bushing.
    - b) Replace bushing if necessary and realign.
- 

#### Push-off rollers do not roll.

---

1. The rollers need lubrication.
    - a) Check zerk hole and grease.
    - b) Remove pin, clean, inspect, and replace if necessary.
  2. The roller bushing is worn out.
    - a) Remove roller assembly and replace bushing.
    - b) See parts manual.
- 

#### Cylinders will not hold in preset position, i.e. the cylinder creeps.

---

1. Seals leaking internally.
    - a) Remove and replace seal kit.
- 

#### Machine cuts unevenly.

---

1. Cutting edges worn unevenly.
    - a) Replace cutting edges.
  2. Improperly inflated tires.
    - a) Check air pressure in tires.
-

## I-130 XL2

### Warranty Statement

# Limited Warranty Statement

Ashland Industries Inc. warrants each new product to be free from defects in material and workmanship. This warranty is applicable only for the normal service life expectancy of the product or components, not to exceed **six consecutive months** from the date of delivery of the new Ashland Industries product to the purchaser, or the date the product is first put into service via a rental agreement or other means, whichever occurs first.

The major components of swivel hitches used on Industrial series scrapers are warranted for three consecutive months from the date of delivery of the new Ashland Industries product to the purchaser, or the date the product is first put into service via a rental agreement or other means, whichever occurs first, except those components described below.

Genuine Ashland Industries Inc. replacement parts and components will be warranted for 30 days from date of purchase, or the remainder of the original equipment warranty period, whichever is longer.

Under no circumstances will it cover any merchandise or components thereof, which in the opinion of the company, has been subjected to misuse, unauthorized modification, alterations, an accident or if repairs have been made with parts other than those obtained through Ashland Industries Inc.

Ashland Industries Inc. in no way warrants Tires since their respective manufacturer warrants these items separately. Please call Ashland Industries Inc. to receive phone numbers of tire suppliers.

Ashland Industries Inc. in no way warrants wearable items such as cutting edges, front dolly wheel balls, socket halves, rollers, bushings, yoke hitch pins, hitch bushings, etc..

Our obligation under this warranty shall be limited to repairing or replacing, free of charge to the original purchaser, any part that, in our judgement, shall show evidence of such defect, provided further that such part shall be returned within 30 days from the date of failure to Ashland Industries Inc. routed through the dealer and distributor from whom the purchase was made, transportation charges prepaid. Upon warranty approval proper credits will be reimbursed for transportation.

This warranty shall not be interpreted to render Ashland Industries Inc. liable for injury or damages of any kind or nature to person or property. This warranty does not extend to the loss revenue, extra labor cost associated with downtime, substitute machinery, rental or for any other reason.

Except as set forth above, Ashland Industries Inc. shall have no obligation or liability of any kind on account of any of its equipment and shall not be liable for special or consequential damages. Ashland Industries Inc. make no other warranty, expressed or implied, and, specifically, Ashland Industries Inc. disclaims any implied warrant or merchantability or fitness for a particular purpose. Some states or provinces do not permit limitations or exclusions of implied warranties or incidental or consequential damages, so the limitations or exclusion in this warranty may not apply.

This warranty is subject to any existing conditions of supply which may direct affect our ability to obtain materials or manufacture replacement parts.

Ashland Industries Inc. reserves the right to make improvements in design or changes in specifications at any time, without incurring any obligation to owners of units previously sold

No one is authorized to alter, Modify or enlarge this warranty nor the exclusion, limitations and reservations.

Ashland Industries Inc.  
Warranty Department