

# Ashland

## EARTHMOVERS



# I-155-TS2

## PARTS MANUAL

ver 2-07



Ashland Industries Inc.  
1115 Rail Drive  
P.O. Box 717  
Ashland, WI. 54806  
877-634-4622 Toll Free - phone  
715-682-4622 phone  
715-682-9717 fax  
[www.ashlandind.com](http://www.ashlandind.com)

MEMBER



CONSTRUCTION INDUSTRY  
MANUFACTURERS ASSOCIATION



# IMPORTANT



Please locate red Transport Links and remove prior to operation. Retract Lift Cylinder Circuit, Remove Safety Snap Pin, Remove link and replace into storage position as shown in figure 2. Reinstall Safety Snap Pins.

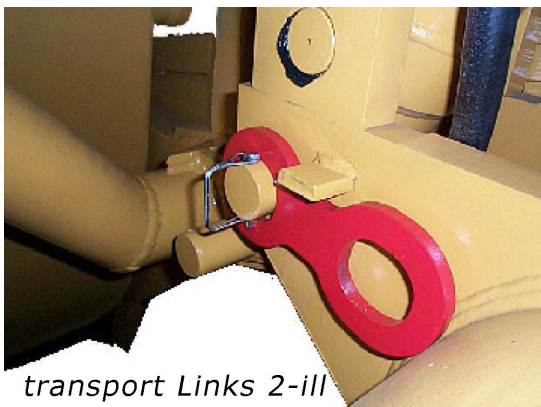



## **HOW TO ORDER PARTS:**

### **IMPORTANT**

Parts must be ordered through your local authorized ASHLAND dealer.

Be sure to state MODEL and SERIAL NUMBER of your machine, PART NUMBER, DESCRIPTION and QUANTITY needed.

Unless this is done, we cannot provide prompt service or assure shipment of the correct parts.



Ashland Industries weldable replacement parts are available to rebuild, modify or update your scraper to current factory specifications.

## **INDEX**

Page	4.	Safety Guidelines
Page	5.	Operators and Maintenance Instructions
Page	6.	Transport Lock-up Links
Page	7.	Complete Yoke Type Hitch
Page	8-10.	Illustration and Parts List - Swivel Hitch Assembly
Page	11.	Illustration and Parts List - Apron Assembly
Page	12.	Illustration and Parts List - Front End Assembly to S/N 20411
Page	13.	Illustration and Parts List - Front End Assembly from S/N 20412
Page	14-15	Illustration and Parts List - Bowl and Frame
Page	16.	Illustration and Parts List - Push Off Gate Assembly
Page	17.	Illustration and Parts List - Rear Wheel and Hub Assembly to S/N 20495
Page	18.	Illustration and Parts List - Rear Wheel and Hub Assembly from S/N 20496
Page	19-21	Illustration and Parts List - Apron Cylinder 4" x 13"
Page	22.	Illustration and Parts List - Lift Cylinder 5" X 20"
Page	23-24	Illustration and Parts List - Push Off Cylinder 5" x 60"
Page	25.	Illustration and Parts List, Nitrogen / Hyd. Accumulator
Page	26.	Illustration and Parts List, Decals
Page	27.	Illus. - Hydraulic Plumbing, Front Unit (Dual Hyd.), Front Section
Page	28.	Illus. - Hydraulic Plumbing, Front Unit, Rear Section to SN 20495
Page	29.	Illus. - Hydraulic Plumbing, Front Unit, Rear Section from SN 20496
Page	30.	Illustration - Hydraulic Plumbing, Rear Unit to SN 20495
Page	31.	Illustration - Hydraulic Plumbing, Rear Unit from SN 20496
Page	32.	Parts List - Hydraulic Plumbing, Rear Unit
Page	33.	Illustration - Hydraulic Plumbing, Hoses, Front Unit to SN 20495
Page	34.	Illustration - Hydraulic Plumbing, Hoses, Front Unit from SN 20496
Page	35.	Illustration - Hydraulic Plumbing, Hoses, Front Unit to SN 20495
Page	36.	Illustration - Hydraulic Plumbing, Hoses, Front Unit from SN 20496
Page	37.	Parts List - Hydraulic Plumbing, Hoses
Page	38-43	Identification, Illustration, Parts List and Adjustment - Hydraulic Valve
Page	44-48	Service Manual Appendix
Page	49-50	Troubleshooting
Page	51.	Warranty Statement



## SAFETY SIGNAL WORDS

Note the use of the signal words DANGER, WARNING and CAUTION with the safety messages. The appropriate signal word for each has been selected using the following guidelines:

**DANGER:** Indicates an imminently hazardous situation that, if not avoided, will result in death or serious injury. This signal word is to be limited to the most extreme situations typically for machine components which, for functional purposes, cannot be guarded.

**WARNING:** Indicates a potentially hazardous situation that, if not avoided, could result in death or serious injury, and includes hazards that are exposed when guards are removed. It may also be used to alert against unsafe practices.

**CAUTION:** Indicates a potentially hazardous situation that, if not avoided, may result in minor or moderate injury. It may also be used to alert against unsafe practices.



## GENERAL SAFETY GUIDELINES

Safety of the operator is one of the main concerns in designing and developing a new piece of equipment. Designers and manufacturers build in as many safety features as possible. However, every year many accidents occur which could have been avoided by a few seconds of thought and a more careful approach to handling equipment. You, the operator, can avoid many accidents by observing the following precautions in this section. To avoid personal injury, study the following precautions and insist those working with you, or for you, follow them.

Replace any CAUTION, WARNING, DANGER or instruction safety decal that is not readable or is missing. Location of such decals is indicated in this booklet.

Do not attempt to operate this equipment under the influence of drugs or alcohol.

Review the safety instructions with all users annually.

This equipment is dangerous to children and persons unfamiliar with its operation. The operator should be a responsible adult familiar with farm machinery and trained in this equipment's operations. **Do not allow persons to operate or assemble this unit until they have read this manual and have developed a thorough understanding of the safety precautions and of how it works.**

To prevent injury or death, use a tractor equipped with a Roll Over Protective System (ROPS). Do not paint over, remove or deface any safety signs or warning decals on your equipment. Observe all safety signs and practice the instructions on them.

Never exceed the limits of a piece of machinery. If its ability to do a job, or to do so safely, is in question - **DON'T TRY IT.**

# **OPERATORS AND MAINTENANCE INSTRUCTIONS**

This scraper is a durable piece of equipment and with proper care will yield many years of trouble free operation. The scraper requires a power source with TWO 4 way (double acting) hydraulic control valves.

The scraper should be greased at all points where grease fittings are provided. Connect hydraulic hoses to the tractor and retract lift cylinders to **REMOVE TRANSPORT LOCK PINS** (point A), then extend and retract all cylinders several times to force out any air from the hydraulic cylinders and lines. Check the oil levels in the tractor hydraulic system and add to maintain the proper level. Care should be used when adding oil or when disconnecting any oil line to keep all dirt out of the oil as dirt is a major factor in the failure of hydraulic components.

When the scraper is placed into operation, the operator will have to "feel out" the amount of depth of cut to obtain maximum loading efficiency. This is usually accomplished by taking a lesser and more uniform cut; however, some soil conditions such as loose sand may require a "pumping action" obtained by taking successive deep cuts and lifting out of cut as the tractor begins to lose power or traction.

1. After 10 hours work, all bolts should be checked and tightened if necessary.
2. Every 10 hours all grease fittings should be lubricated.
3. After 50 hours work, all bolts should be rechecked and tightened if necessary. Check wheel bearings and adjust if necessary.
4. After 300 hours work, clean and repack wheel bearings and replace, if necessary, cutting edges, worn pins, etc.
5. Tighten all wheel bolts after first two hours use. Check daily for two weeks. Keep torqued to 750 ft. lbs..
6. Maintain tire pressure at 45 to 50 psi.

**Transport Lock Links  
I-155 TS  
Serial Number 20521 and above**

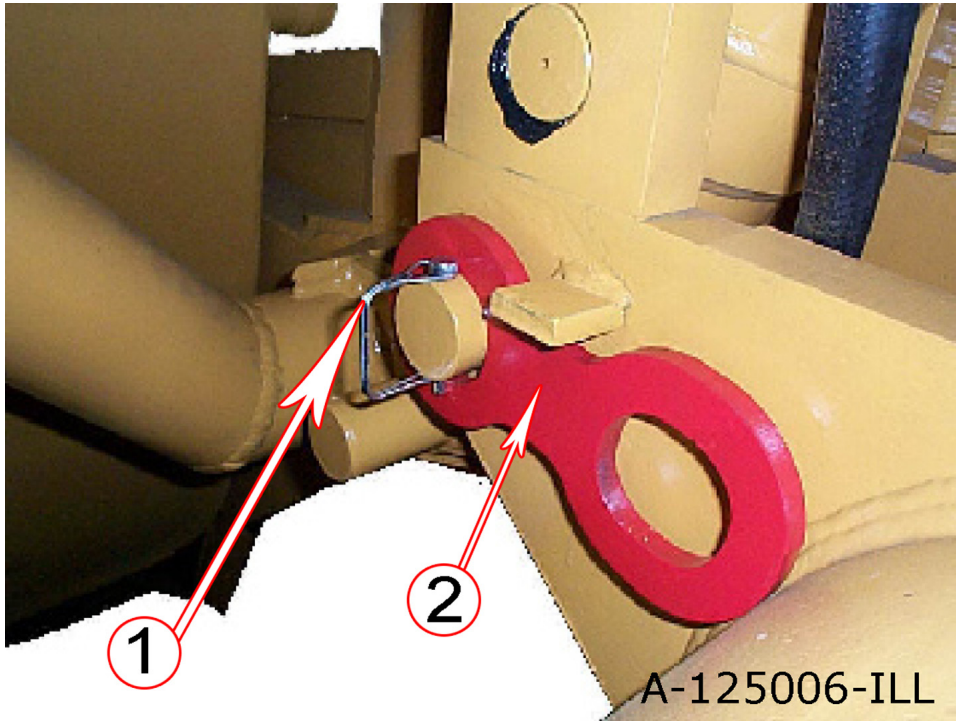

<b>KEY NO.</b>	<b>PART NO.</b>	<b>DESCRIPTION</b>
1.	A125006	Pin, Safety Snap Pin
2.	A123309-83	Link, Transport Lock, Red

# A125056

## Complete Yoke Type Hitch

Implemented April 2003

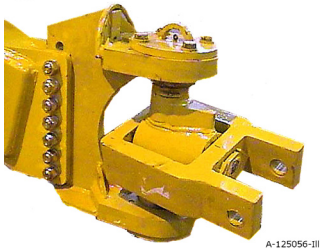

A-125056-III

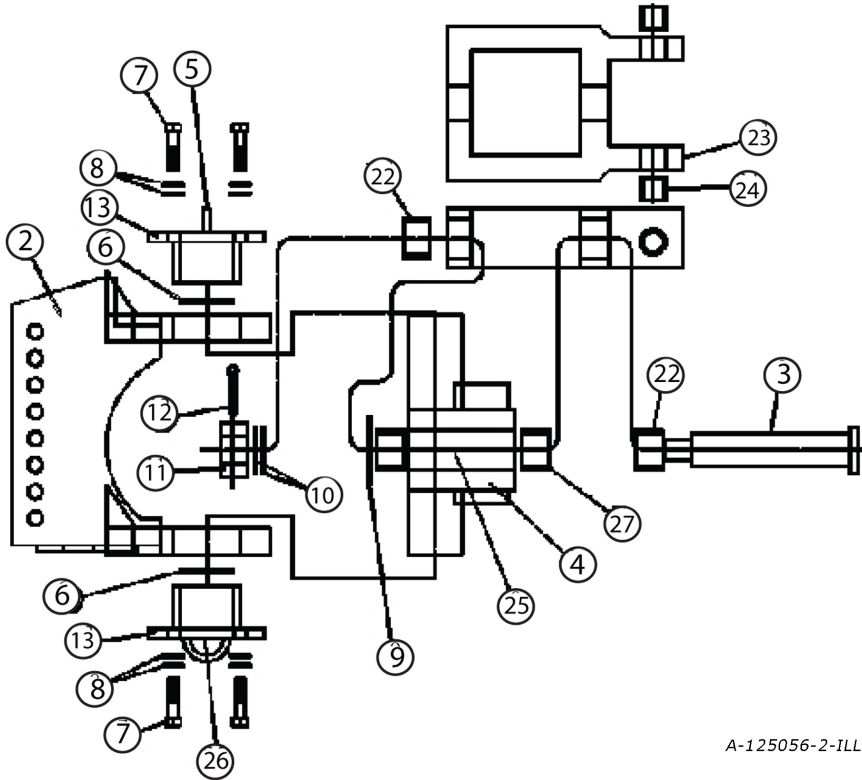

A-125056-2-ILL

<b>KEY NO.</b>	<b>PART NO.</b>	<b>DESCRIPTION</b>
2.	A125056-02	UTIL HITCH BRKT
3.	A125056-03	MDU HITCH PIN
4.	A125056-25	MDU HITCH SWIVEL
5.	A125056-05	19C 18D HITCH CAP
6.	A125056-06	19C 18D WASHER SWIVEL HITCH
7.	A125056-07	BOLT: 3/4 X 3 HEX GR 8
8.	A125056-08	WASHER: FLAT - 3/4 HARD F-436
9.	A125056-09	WASHER: FKAT-2-1/2 HARD F-436
10.	A125056-10	WASHER: FLAT-1-1/2 HARD F-436
11.	A125056-11	NUT: SLOTTED 1-1/2 COARSE
12.	A125056-12	PIN: COTTER 5/16 X 2-1/2
13.	A125056-13	19C 18D SWIVEL HITCH CAP SEAL
23.	A125056-23	REYNOLDS UTILITY HITCH YOKE
24.	A125056-24	BUSHING: 175150150
25.	A125056-25	ZERK - STRAIGHT
26.	A125056-26	ZERK - 90 DEGREE
27.	A125056-27	BUSHING: 300251200

# SWIVEL HITCH ASSEMBLY

## I-155 TS2

### A125223

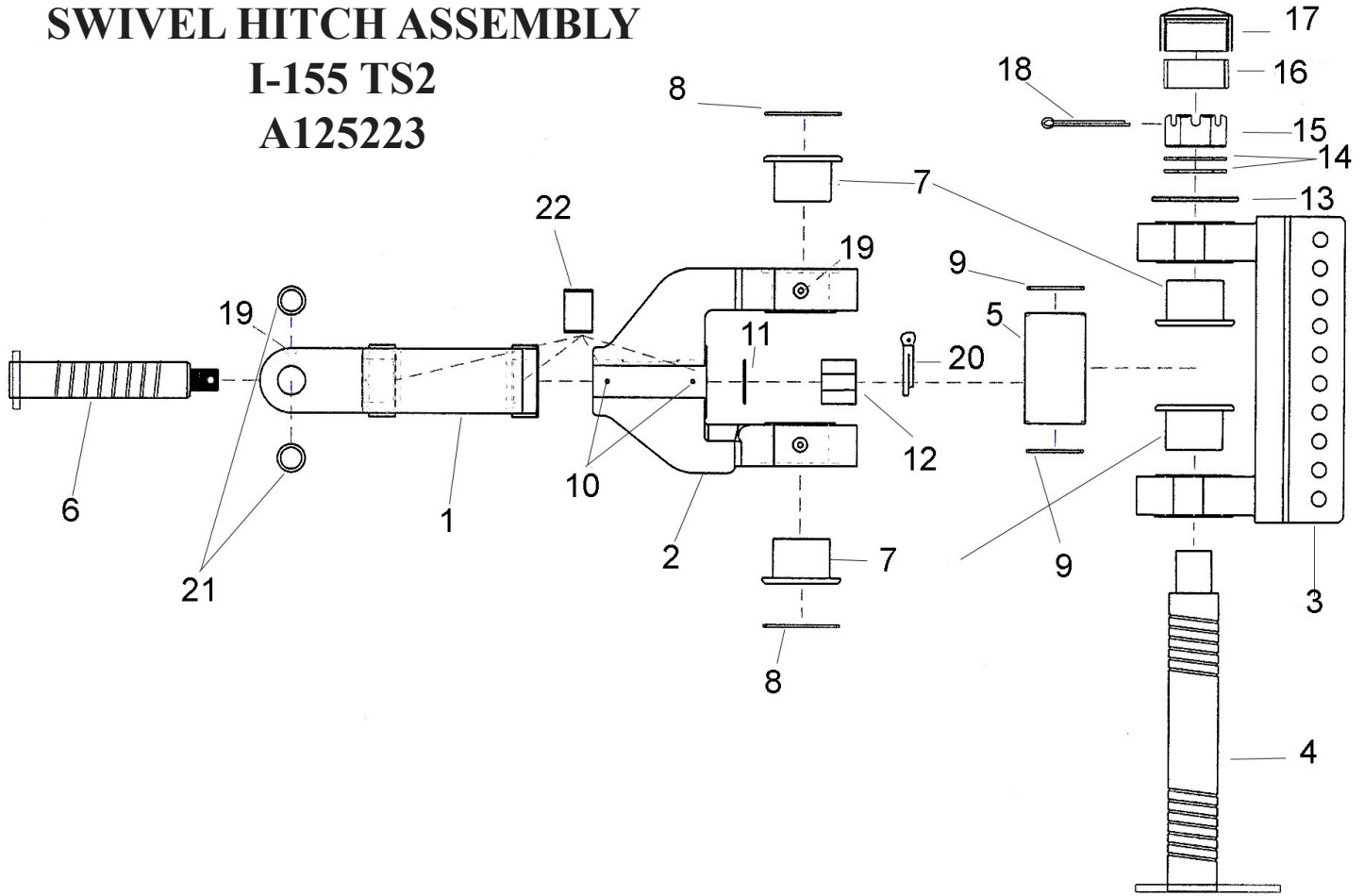

KEY #	PART NUMBER	QUANTITY REQUIRED	DESCRIPTION
1	A125223-01	1	Yoke: A-Frame
2	A125223-02	1	Swivel
3	A125223-03	1	Bracket: 10 Hole
4	A125223-04	1	Pin: Main Vertical
5	A125223-05	1	Spacer: 6"
6	A125223-06	1	Pin Horizontal
7	A125223-07	4	Bushing
8	A125223-08	2	Seal: O-ring
9	A125223-09	2	Seal: O-ring
10	AFH-00028	2	Grease Fitting: 90°
11	A125223-11	2	Washer- 1-1/2" For Horizontal Pin
12	A125223-12	1	Nut: Slotted 1-1/2" NC
13	A125223-13	1	Spacer: 6"
14	A125223-14	2	Washer: 2 1/2"
15	A125223-15	1	Nut: Slotted 2-1/2" NC
16	A125223-16	1	Sleeve: 2" Rubber
17	A125223-17	1	Cap: For Vertical Pin
18	A125223-18	1	Pin: Cotter 3/8 x 5"
19	14505	4	Grease Fitting Straight
20	8613	1	Cotter Pin: 5/16 x 2-1/2"
21	A125056-24	2	Bushing
22	A125056-27	2	Bushing



# Icon Swivel Hitch

## A-125224 (optional)

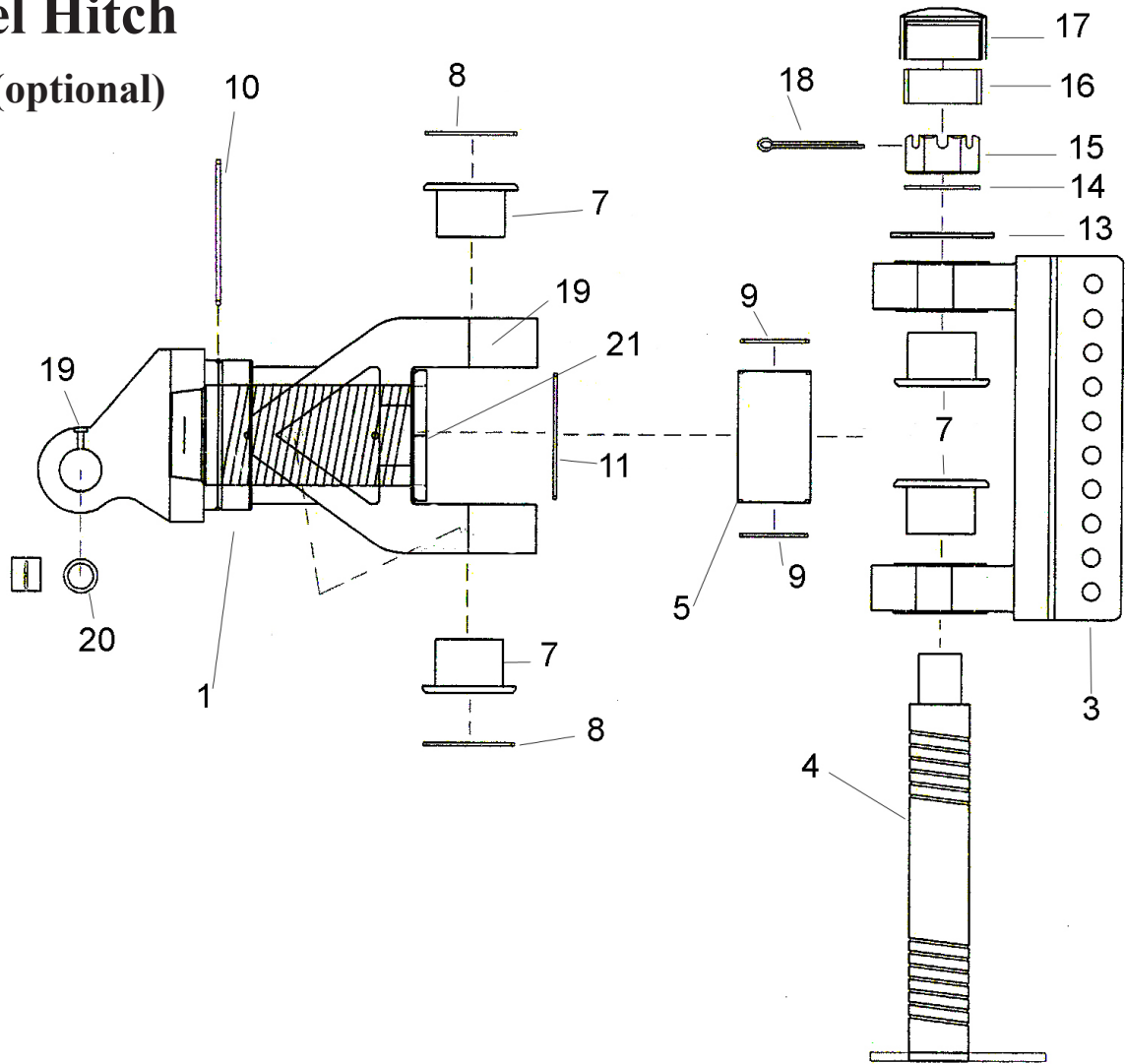

KEY #	PART NUMBER	QUANTITY REQUIRED	DESCRIPTION
1	A125224-01	1	Yoke: A-Frame swivel
3	A125224-03	1	Bracket: 10 Hole
4	A125224-04	1	Pin: Main Vertical
5	A125224-05	1	Spacer: 6"
7	A125224-07	4	Bushing
8	A125224-08	2	Seal: O-ring
9	A125224-09	2	Seal: O-ring
10	A125224-10	2	O-ring
13	A125224-13	1	Spacer: 6"
14	A125224-14	2	Washer: 2 1/2"
15	A125224-15	1	Nut: Slotted 2-1/2" NC
16	A125224-16	1	Sleeve: 2" Rubber
17	A125224-17	1	Cap: For Vertical Pin
18	A125224-18	1	Pin: Cotter 3/8 x 5"
19	14505	4	Grease Fitting Straight
20	A125056-24	2	Bushing
21	AHF-00027	1	Zerk 45°

# SUPER CAPACITY SWIVEL HITCH ASSEMBLY A125057

**COMPLETE HITCH: H.D. ICON 360 DEG. SWIVEL**

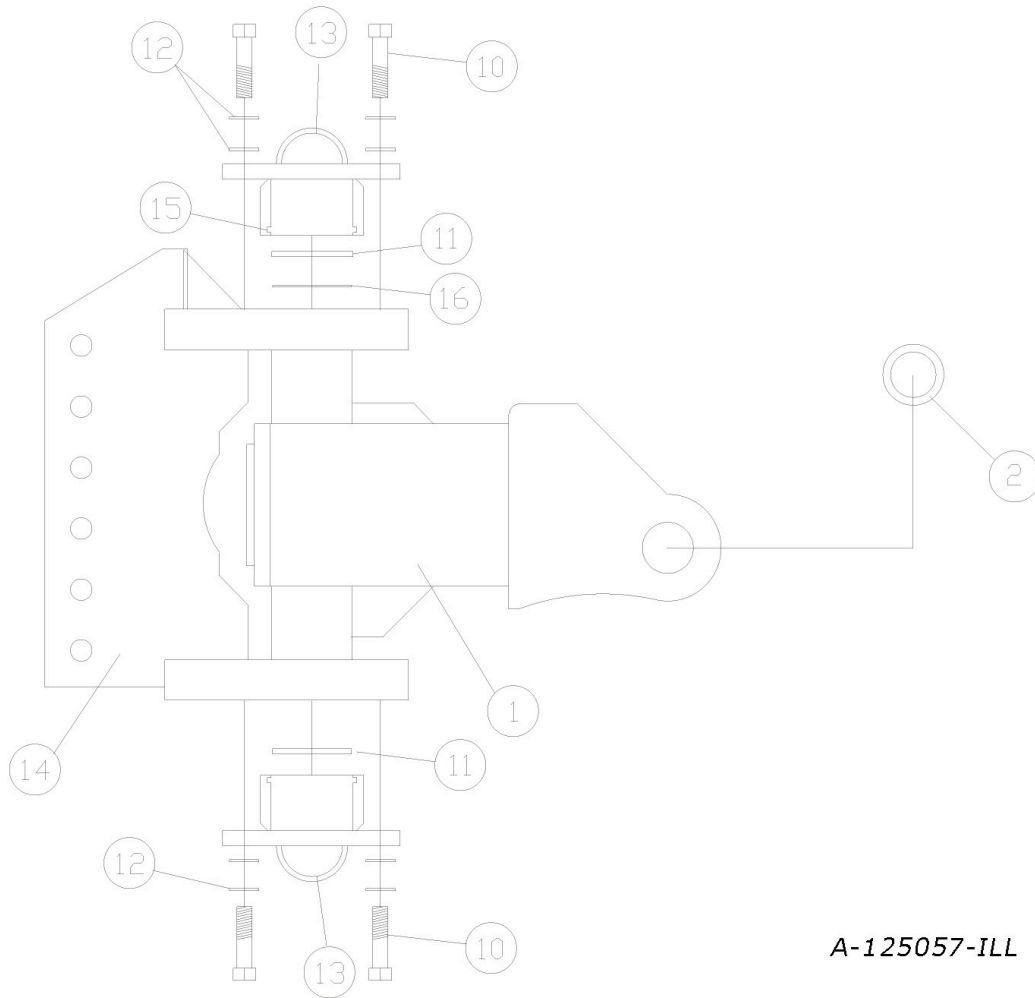

A-125057-ILL

<b>ITEM</b>	<b>QTY</b>	<b>PART NUMBER</b>	<b>DESCRIPTION</b>
1	1	A125057-01	Swivel Hitch Yoke
2	2	A125057-02A	Bushing, 2-1/2" OD, Reynolds Spec.
		A125057-02JD	Bushing, 60 mm ID, John Deere Spec.
10	8	AFB-00064	HHCS: 3/4 NC X 3" GR. 8 ZINC
11	2	A125056-06	WASHER: FOR ICON HITCH CAP
12	16	AFW-00007	WASHER: FLAT 3/4" ZINC USS
13	2	A125057-13	HITCH CAP, ICON
14	1	A125057-14	SWIVEL HITCH BRACKET, 7 HOLE
15	2	A125057-15	SEAL, HITCH CAP
16	1	A125057-16	SHIM, HITCH CAP

# I-155TS SUPER SWIVEL HITCH ASSEMBLY

Used on scrapers up to March 2003

## IMPORTANT

Some units prior to this serial number were upgraded to a H.D. cast type yoke hitch (page 6) by the customer. Please determine if the entire yoke hitch is casted or flat steel. The Casted Hitch has "OFCO" casted into the A-Frame Hitch.

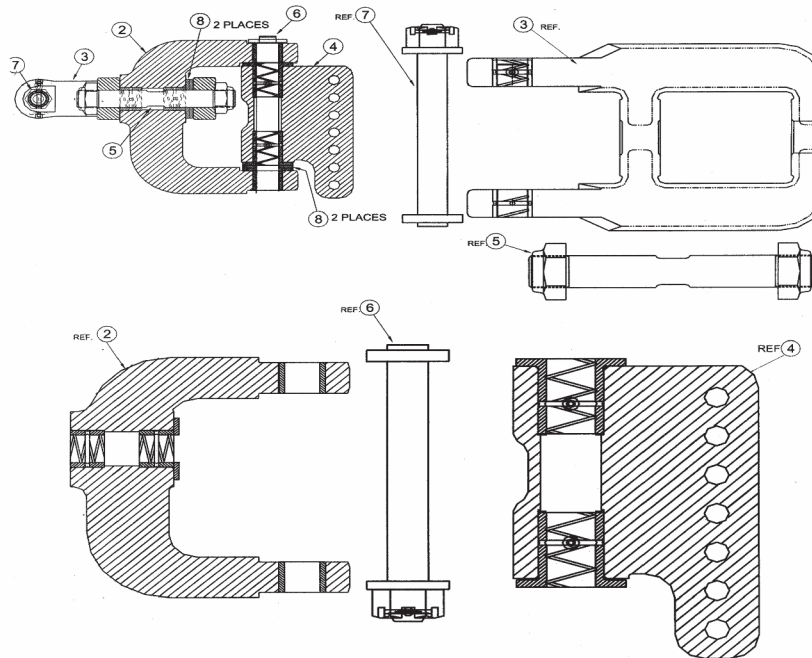

A-1063285-III

KEY NO.	PART NO.	DESCRIPTION
1.	A1063527	Super Yoke hitch, Includes 2 & 3, (w/o 4,6,7 & 1 ea. of 8) (Required 1)
2.	A1062280	Rear Super Yoke, Assembly (1 required)
	A1063177	Bushing ( 2 required)
	A1063144	Bushing, Spiral (2 required)
	14505	Fitting, Grease (2 required)
3.	A1063281	Front Super Yoke, Assembly (1 required)
	A1063145	Busing, Spiral (2 required)
	14505	Fitting, Grease (2 required)
4.	A1063282	Pivot Pin Housing, Assembly (1 required)
	A1063143	Bushing, Spiral (2 required)
	14505	Fitting, Grease (2 required)
5.	A1063283	Pin, Horizontal Assembly with Nuts (1 required)
	A1063212	Pin only (1 required)
	A1044362	Nut, Lock Nylon, 2-12 UNF (2 required)
6.	A1063284	Pin, Vertical Assembly with nut,wash,c.pin (1 required)
	A1063214	Pin only (1 required)
	A1063259	Washer (1 required)
	ARF03024-00260	Nut, Slotted. Hex 2.00 NC G5 (1 required)
	ARF06020-00083	Pin, Cotter .375" x 4.00" (1 required)
7.	AB581	Hitch Pin, Assembly (1 required)
	AB580	Pin Weldment (1 required)
	AB195	Washer, 3.00"OD x 1.56" (1 required)
	AFN-00014	Nut, Slotted, 1.5" NC G5 (1 required)
	ARF06020-00060	Pin, Cotter
8.	A1063146	Washer, Thrust (4 required)
	A1063285	Complete Hitch

# SWIVEL HITCH ASSEMBLY I-155 TS

Up to Serial Number 20495  
I-155TS Front Unit

## IMPORTANT

Some units prior to this serial number were upgraded to a H.D. cast type yoke hitch (page 6) by the customer. Please determine if the entire yoke hitch is casted or flat steel. The Casted Hitch has "OFCO" casted into the A-Frame Hitch.

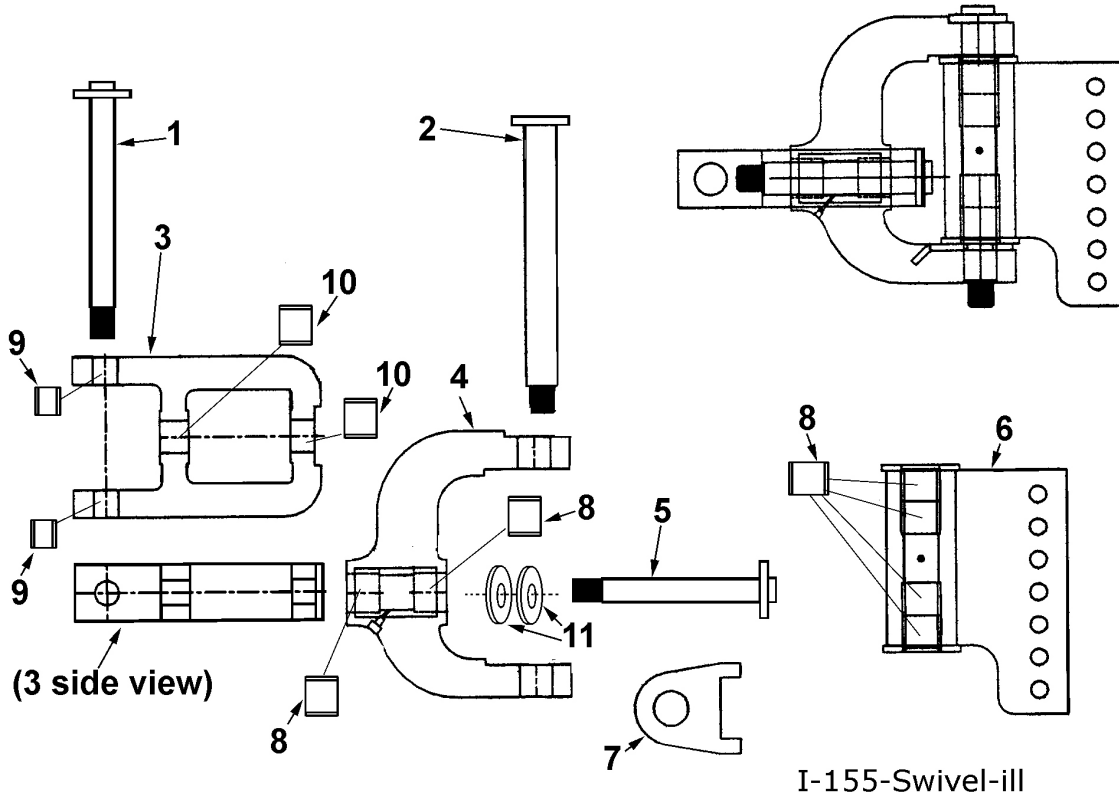

KEY NO.	PART NO.	DESCRIPTION
1.	A123299-08	Pin: Four Ear Drawbar To Hitch
	A123299-07	Pin: Two Ear Drawbar To Hitch
	AFN-00014	Nut: 1-1/2" NC Slotted
2.	A123299-06	Pin: Sq. Tab Head 2 X 18-1/2"
	AFN-00018	Nut: 1-1/2" NF Top Lock
3.	A123299-03	RA-Frame Hitch
4.	A123299-02	C-Frame Hitch: Offset
5.	A123299-05	Pin: Sq. Tab Head 1-1/2 NF X 12-1/2"
	AFN-00018	Nut: 1-1/2" NF Top Lock
6.	A123299-01	Vertical Mounting Tube: 7 Hole
7.	A123299-04	Wear Pad With Locking Legs
8.	ABS-00001	Bushing: Spring 2" ID X 2-3/8" OD
9.	A123299-09	Bushing: 2" OD x 1-1/2" ID x 1-1/2" (2 req'd)
10.	A123299-10	Bushing: 2-3/8" OD x 2" ID x 1-1/2" (2 req'd)
11.	A123299-11	Washer
12.	A123299-14	Thrust Bushing with Flange, 2" ID x 2-3/8" OD

# I-155TS APRON ASSEMBLY

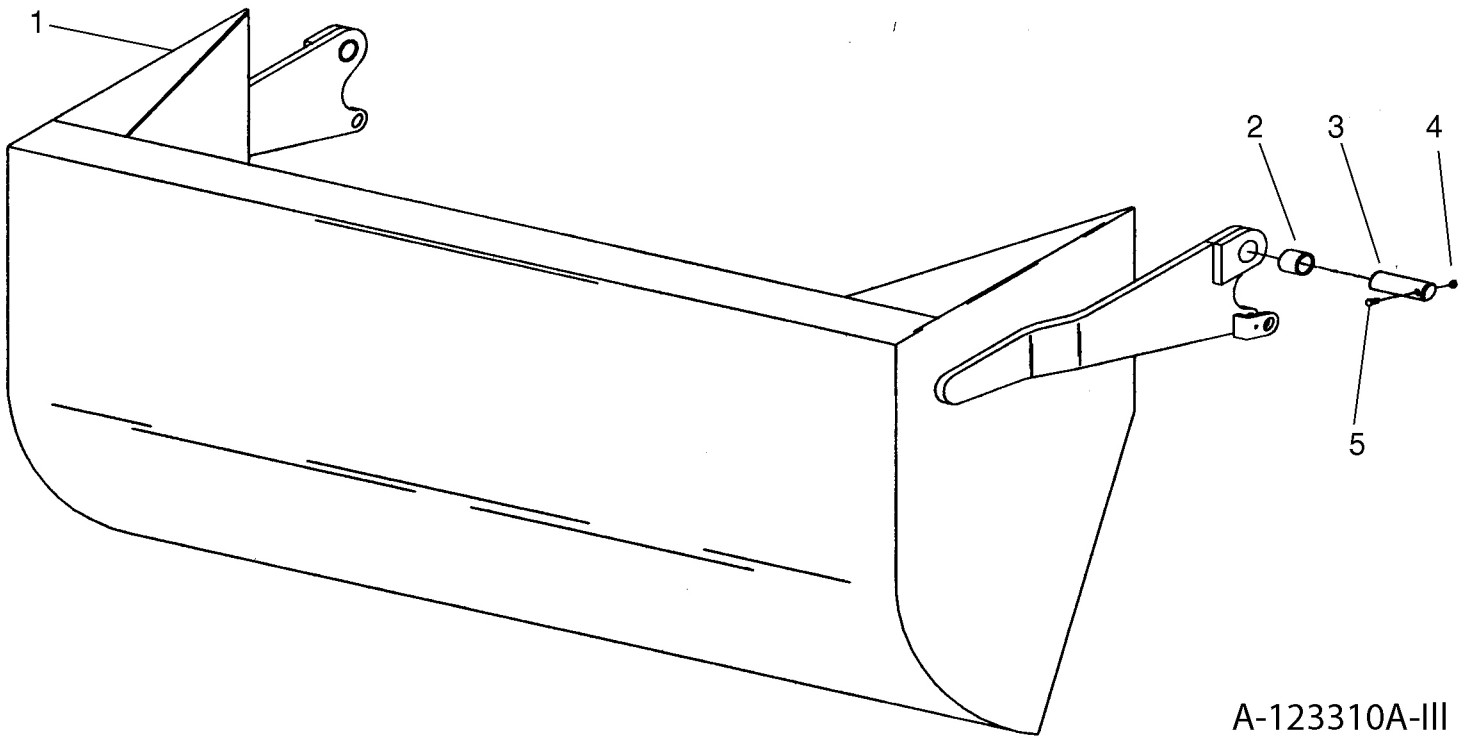

A-123310A-III

<b>KEY NO.</b>	<b>PART NO.</b>	<b>DESCRIPTION</b>
1.	A123310A	Apron Model I-155 TS
2.	A16027	Bushing: 2" OD x 1-1/2" ID x 2" Long
3.	A123337	Pin: 1-1/2" x 5-3/8"
4.	7450	Nut: 3/8" NC
5.	AFB-00049	Bolt: 3/8" NC x 3"

# MODEL I-155TS

## FRONT END WITH 2 PIECE TRUNION MOUNT BLOCK

FOR MODELS WITH S/N 20326 TO 20411 ONLY

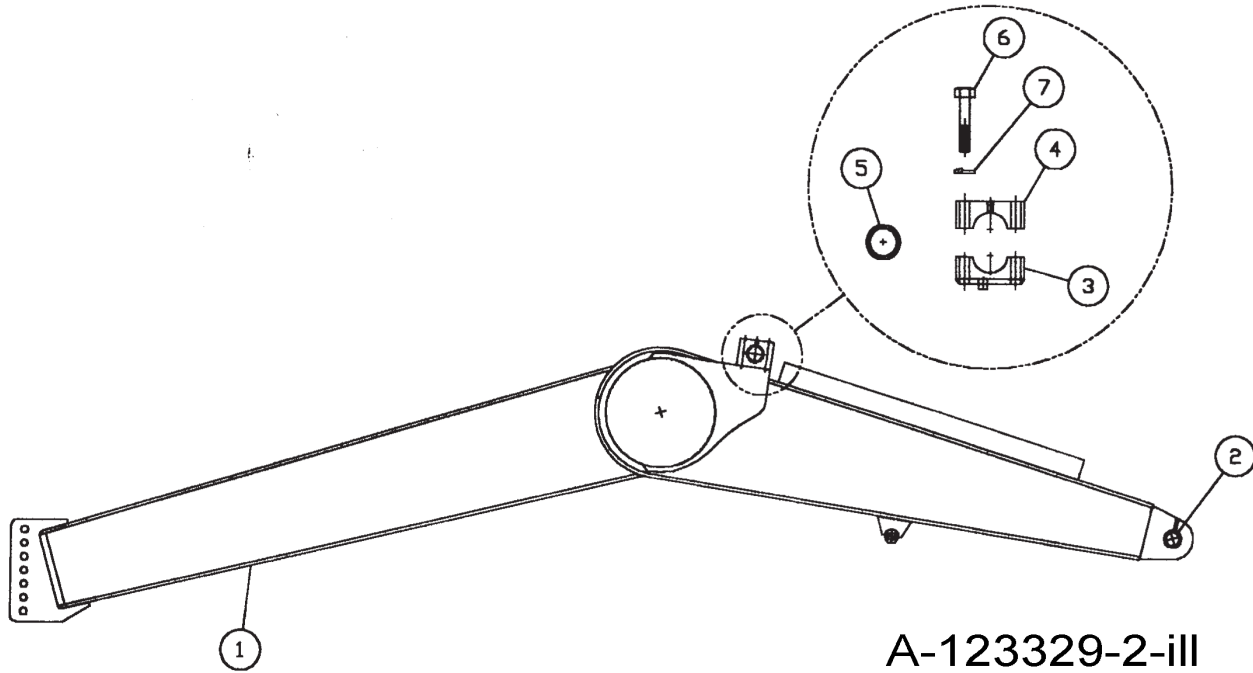

<b>KEY NO.</b>	<b>PART NO.</b>	<b>DESCRIPTION</b>
1.	A123329	Front End Assembly
2.	A14039	Bushing: 2.375 OD X 2.000 ID X 2" Long
3.	A1230501-01	Trunion Mount Block - Lower Half
4.	A1230501-02	Trunion Mount Block - Upper Half
5.	A123502	Bushing
6.	AFB-00064	HHCS: 3/4 NC X 3" Gr. 8
7.	AFW-00002	Washer: 3/4" Lock
8.	A10152A	Pin Frame Attachment, 2" OD x 8-1/8" Long

## MODEL I-155 TS FRONT END

FOR MODELS WITH S/N 20412 AND UP

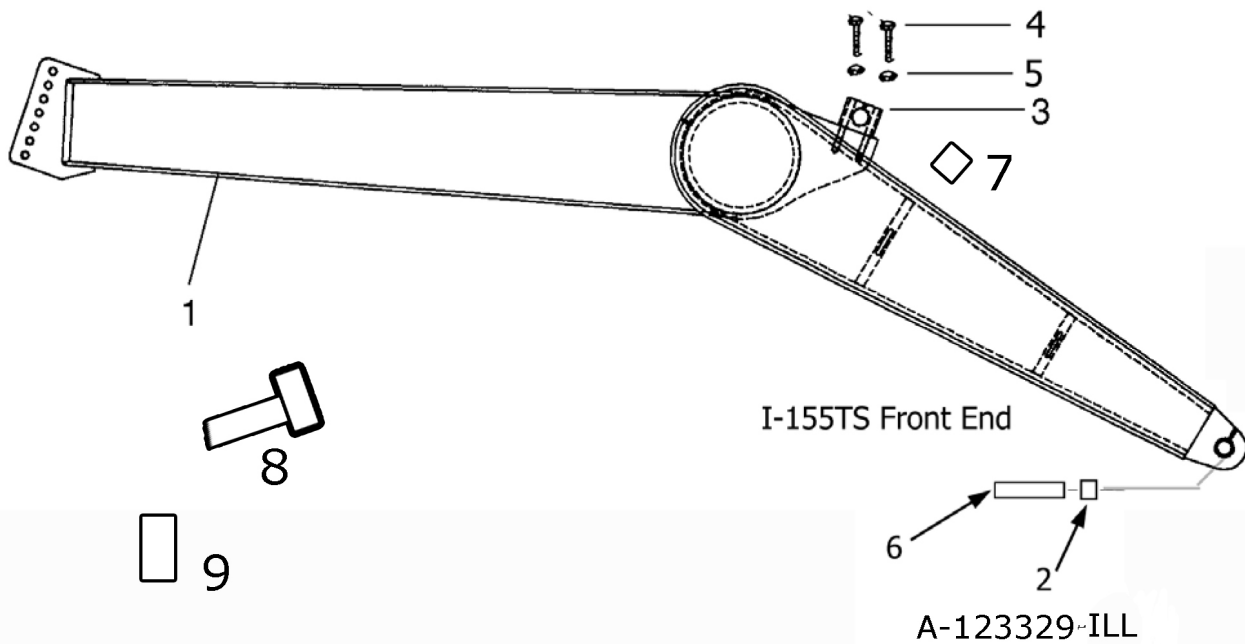

<b><u>KEY NO.</u></b>	<b><u>PART NO.</u></b>	<b><u>DESCRIPTION</u></b>
1.	A123329	Front End Assembly
2.	A14039	Bushing: 2.375 OD X 2.000 ID X 2" Long
3.	A123456	Trunion Mount Block
4.	AFB-00039	Bolts, 3/4" x 5-1/2"
5.	AFW-00002	Lockwasher, 3/4"
6.	A10152A	Pin, Frame Attachment, 2" OD x 8-1/8" Long
7.	A125179	Bushing
8.	AFB-00021	Bolt 1" x 5-1/2 NC Gr 8 (7 required)
9.	AFN-00037	Nut 1" NC Locknut (7 required)

# MODEL I-155 TS2 BOWL & FRAME ASSEMBLY

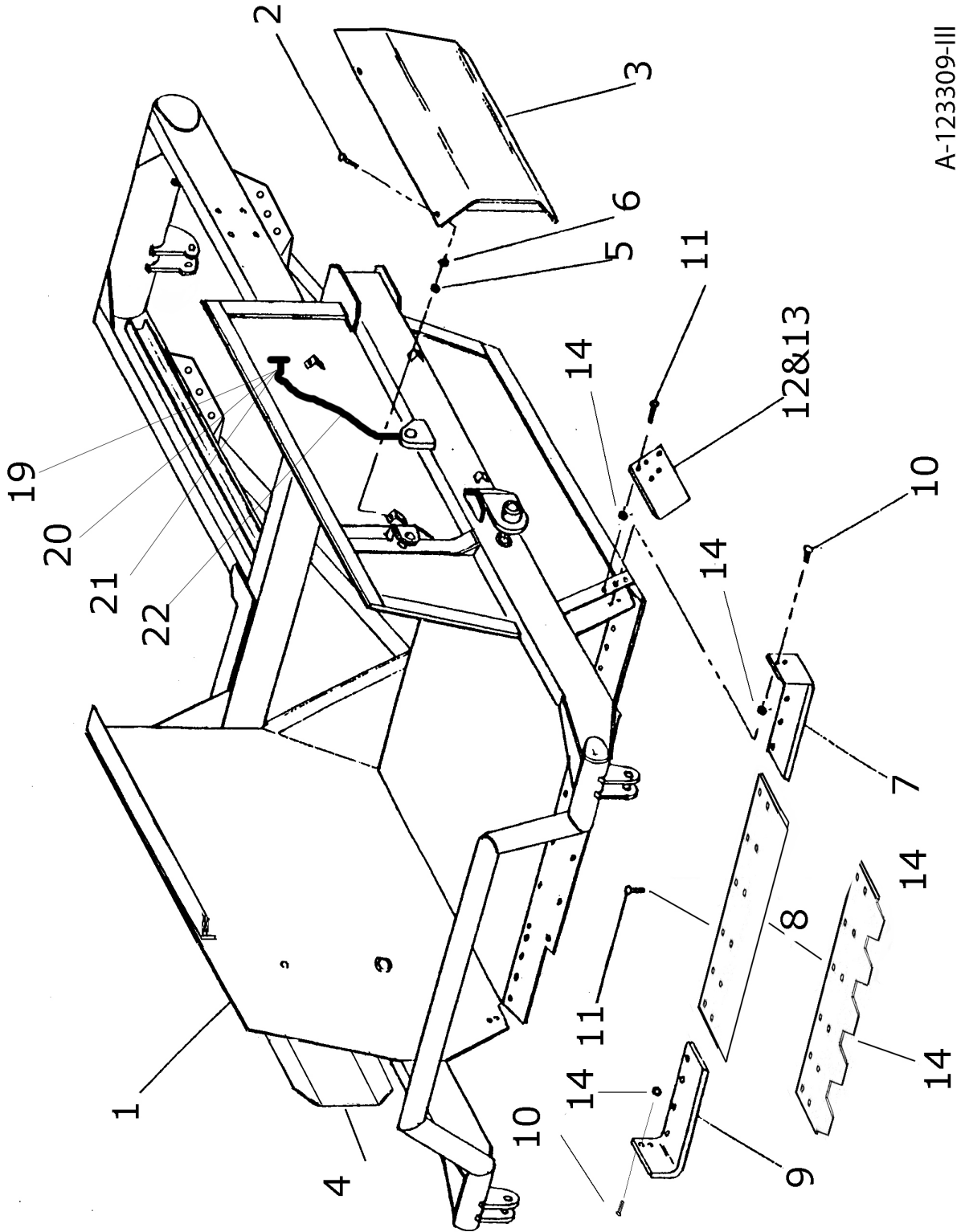

A-123309-III



**MODEL I-155 TS2  
BOWL & FRAME ASSEMBLY**

<b><u>KEY NO.</u></b>	<b><u>PART NO.</u></b>	<b><u>DESCRIPTION</u></b>
1.	A123309	Bowl and Frame, Model I-155
2.	AFB-00094	Flanged Bolt: 3/8 NC X 1"
3.	A10157 A123309-77 A123309-62L	to S/N 20495: Cylinder Guard - Left Hand S/N 20496 to S/N 20749: Cylinder Guard - Left Hand S/N 20750 and above
4.	A10158 A123309-62R	Cylinder Guard - Right Hand to S/N 20749 S/N 20750 and above
7.	A123332L	Left Cutting Edge
8.	A123330SER A123330 PB9P-NC-088-0275	Center Cutting Edge, Serrated 1-1/8" x 12" x 63" Center Cutting Edge, Straight 1-1/8" x 12" x 63" Plow Bolt 7/8" x 2-3/4", 12 Required
9.	A123332R	Right Cutting Edge
10.	PB9P-NC-088-0275	Plow Bolt: 7/8 NC X 2-3/4", 6 Required
11.	AFB-0018	Bolt, 1" NC x 3" long, 5 per Blade Required
12.	A123357	Bank Shaver/router bit Reversible, L & R
13.	AFN-00012	Nut: 1" NC, 5 per Blade Required
14.	AFN-00019	Nut: 7/8" NC, 6 Required
15.	A123309-93	3" Locking Lug for Rear Hitch
16.	A123309-96	Pin (2 Reg) for Locking Lug
17.	AFP-00001	Pin Cotter, 1/4" x 3"
18.	A125006	Safety Snap Pin
19.	A125019	Grease Fitting 1/4 x 28.54 long
20.	A125026	Bulkhead Nut
21.	A123306-89	Single Hole Tab
22.	A125022	18" Grease Line

# I-155TS2 PUSH OFF GATE ASSEMBLY Up to S.N. 21458

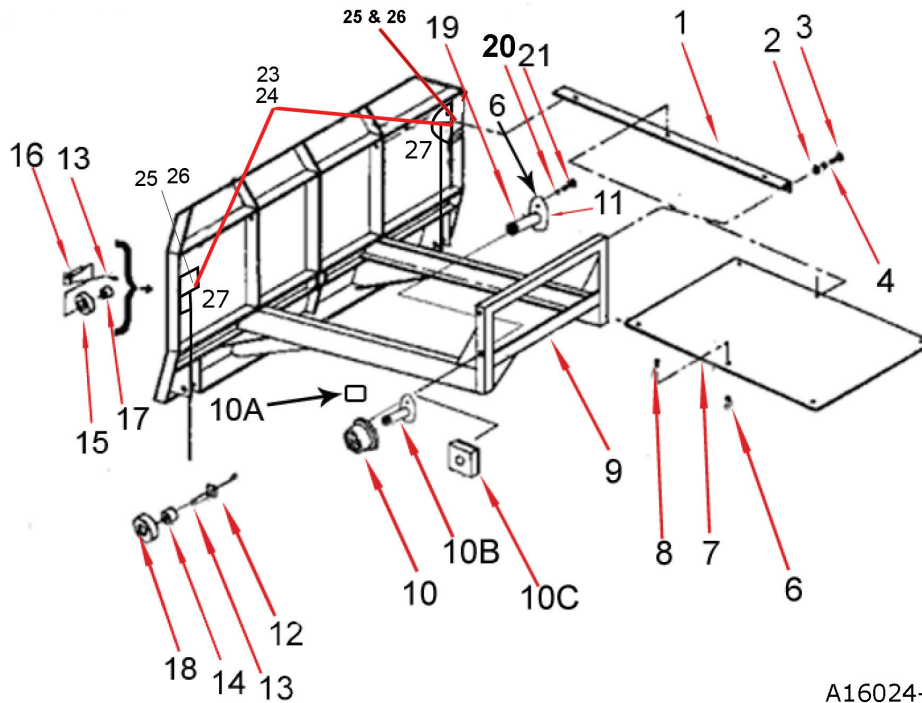

A16024-III

<u>KEY NO.</u>	<u>PART NO.</u>	<u>DESCRIPTION</u>
1.	A14022	Brace
2.	AFN-00006	Nut: 3/4" NC
3.	AFB-00037	Bolt: 3/4" NC x 2" Lg.
4.	AFW-00002	Lockwasher: 3/4"
5.	8100	Lockwasher: 1/2"
6.	AFN-00015	Nut: 1/2" NC
7.	A14023	Dirt Shield
8.	AFB-00015	Bolt: 1/2" NC x 1-1/2"
9.	A16024	Pushoff Gate: Model I-150
10.	A123306	To S.N. 20495: Roller: Rear Gate
10A.	A123307	To S.N. 20495 Bushing
10B.	A123305A	Pin: 1-1/4 X 2-3/4" for Wear Pad
10C.	A123353	Wear Pad
11.	AHF-00028	Grease Fitting: 1/8" NPT -90 degree
12.	A6007A	Pin: 1-1/4" x 4-1/8" Lg.
13.	AFP-00001	Cotter Pin: 1/4 X 3-1/2"
14.	A10163	Bushing: 1-3/4" OD x 1-1/4" ID
15.	A123459	V-Roller: 3-1/2 OD X 1-3/4 ID
16.	A123323-21	Pin: 1-1/4 X 4 1/8" Tab Head
17.	7036	Bolt: 1/2 NC X 2"
18.	A10163	Bushing: 1-3/4" OD x 1-1/4" ID
19.	A10164	Roller: 4-1/4 OD X 1-3/4 ID.
20.	A123305A	Pin: 1-1/4 x 2-3/4" w/grease for Roller
21.	8100	Lockwasher: 1/2"
22.	AFB-00033	Bolt: 1/2 NC X 2-1/2"
23.	A125020	Remote Grease Lines, 32" (2)
24.	A125021	Remote Grease Lines, 54" (2)
25.	A125019	Grease Fitting 1/4 x 28.54 Long (4)
26.	A125026	BulkHead Nut (4)
27.	A123323-40	Double Hole Tab (2)

# I-155TS2 Push Off Assembly

## S.N. 21459 And Up

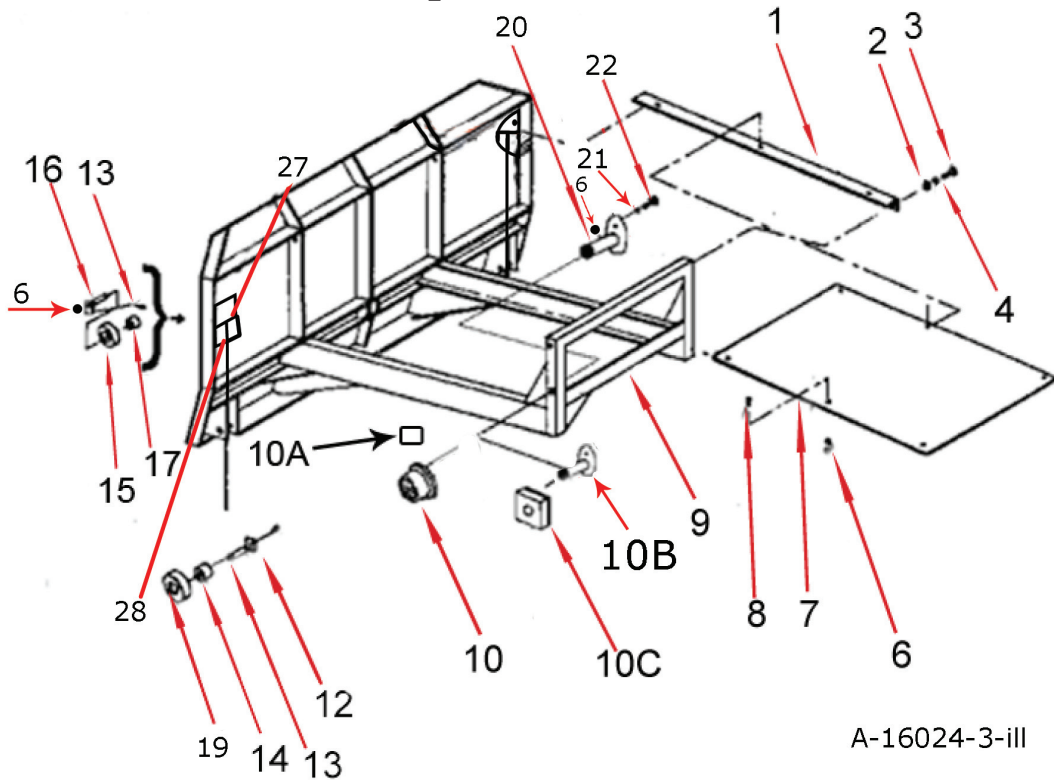

<u>KEY NO.</u>	<u>PART NO.</u>	<u>DESCRIPTION</u>
1.	A14022	Brace
2.	AFN-00006	Nut: 3/4" NC
3.	AFB-00037	Bolt: 3/4" NC x 2" Lg.
4.	AFW-00002	Lockwasher: 3/4"
5.	8100	Lockwasher: 1/2"
6.	AFN-00015	Nut: 1/2" NC
7.	A14023	Dirt Shield
8.	AFB-00015	Bolt: 1/2" NC x 1-1/2"
9.	A16024	Pushoff Gate: Model I-150
10.	A123306	To S.N. 20495: Roller: Rear Gate
10A.	A123307	To S.N. 20495 Bushing
10B.	A123305A	Pin: 1-1/4 X 2-3/4" for Wear Pad
10C.	A123353	Wear Pad
11.	AHF-00028	Grease Fitting: 1/8" NPT -90 degree
12.	A6007A	Pin: 1-1/4" x 4-1/8" Lg.
13.	AFP-00001	Cotter Pin: 1/4 X 3-1/2"
14.	A10163	Bushing: 1-3/4" OD x 1-1/4" ID
15.	A123459	V-Roller: 3-1/2 OD X 1-3/4 ID
16.	A123323-21	Pin: 1-1/4 X 4 1/8" Tab Head
17.	7036	Bolt: 1/2 NC X 2"
18.	A10163	Bushing: 1-3/4" OD x 1-1/4" ID
19.	A10164	Roller: 4-1/4 OD X 1-3/4 ID.
20.	A123305	Pin: 1-1/4 x 2-3/4" w/grease for Roller
21.	8100	Lockwasher: 1/2"
22.	AFB-00033	Bolt: 1/2 NC X 2-1/2"
??	A125019	Grease Fitting 1/4 x 28.54 Long (4)
26.	A125026	BulkHead Nut (4)
27.	A123323-40	Double Hole Tab (2)

Up to S.N. 20495 (5 hole Spindle)

**IMPORTANT**

Some units prior to this serial number were upgraded to a 7 spindle by the customer via a special upgrade offer. Be sure to check if unit has 7 bolt spindle base plate.

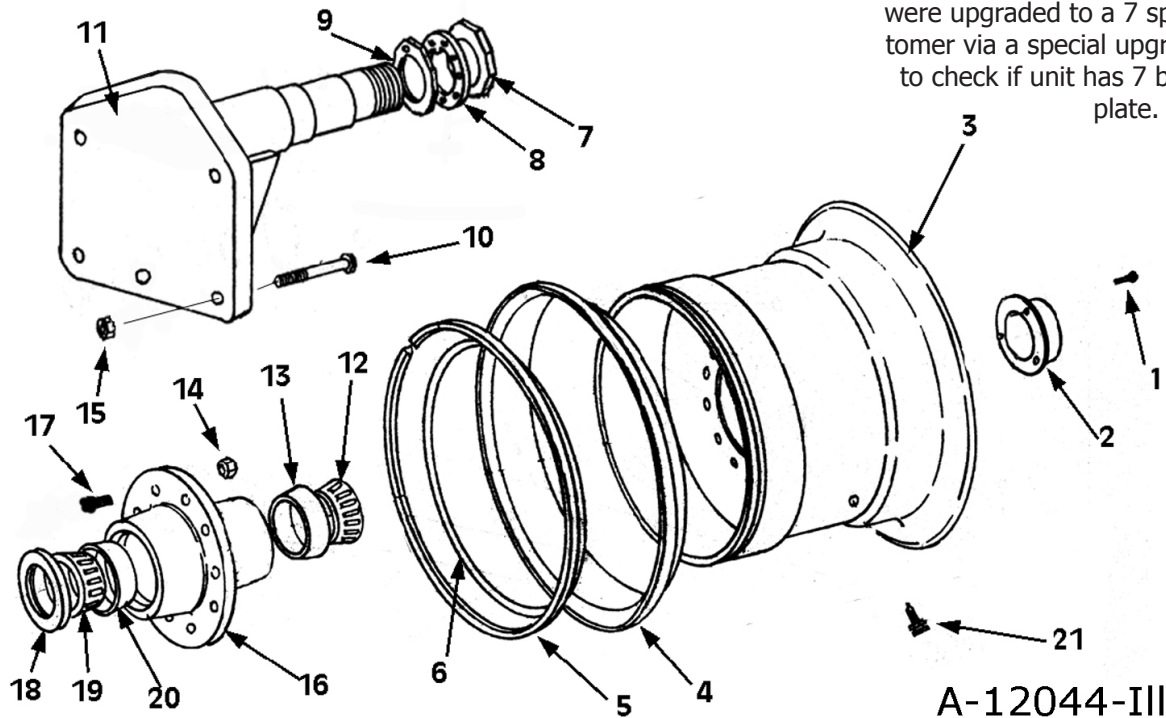

**PARTS LIST**  
**REAR WHEEL and HUB ASSEMBLY**  
**MODEL I-155 TS**

<b>KEY NO.</b>	<b>PART NO.</b>	<b>DESCRIPTION</b>
1.	AFB-00080	Bolt 5/16" NC X 1/2" Lg.
2.	A14004	Hub Cap
3.	A12036	Wheel Ass'y. 25" x 25"
	A12036-1	Center Dish Weldment, Flat
	A12036-2	Six Gussets for Center Dish
4.	A12041	Side Ring
5.	A12042	Lock Ring
6.	A12047	O-Ring
7.	A10048	Spindle Nut
8.	A10049A	Lock Collar
9.	A10172	Nut with Lock Pin
10.	AFB-00067	Bolt 1-1/4" NF X 7-1/2" Lg.
11.	A12044	Spindle
12.	A14015	Bearing Cone (Timken# 644)
13.	A14014	Bearing Cup (Timken# 632)
14.	A12051	Lug Nut
15.	AFN-00009	Lock Nut: 1-1/4" NF
16.	A12035	Hub
17.	A12050	Lug
18.	A12037	Grease Seal (National# 416039)
19.	A12038	Bearing Cup (Timken# 854)
20.	A12039	Bearing Cone (Timken#861)
21.	A14016	Valve Stem

S.N. 20496 & up (7 hole Spindle)

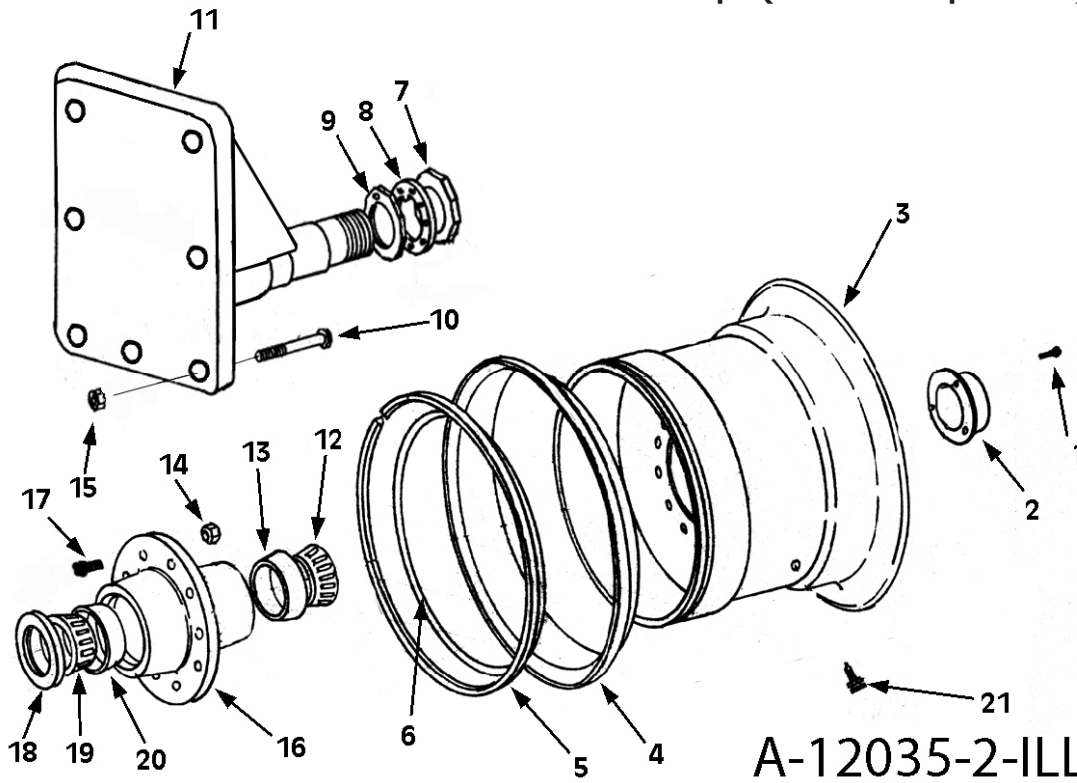

**IMPORTANT**

Some units prior to this serial number were upgraded to a 7 spindle by the customer via a special upgrade offer. Be sure to check if unit has 7 bolt spindle base plate.

**REAR WHEEL and HUB ASSEMBLY  
MODEL I-155 TS**

<b>KEY NO.</b>	<b>PART NO.</b>	<b>DESCRIPTION</b>
1.	AFB-00080	Bolt 5/16" NC x 1/2" Lg.
2.	A14004	Hub Cap
3.	A12036	Wheel Ass'y. 25" x 25"
	A12036-1	Center Dish Weldment, Flat
	A12036-2	Six Gussets for Center Dish
4.	A12041	Side Ring
5.	A12042	Lock Ring
6.	A12047	O-Ring
7.	A10048	Spindle Nut
8.	A10049A	Lock Collar
9.	A10172	Nut with Lock Pin
10.	AFB-00067	Bolt 1-1/4" NF X 7-1/2" Lg.
11.	A123350	Spindle
12.	A125001	Bearing Cone (Timken# H715348)
13.	A125002	Bearing Cup (Timken# H715311)
14.	A12051	Lug Nut
15.	AFN-00009	Lock Nut: 1-1/4" NF
16.	A12035	Hub
17.	A12050	Lug
18.	A12037	Grease Seal (National# 416039)
19.	A125003	Bearing Cone (Timken# HM624749)
20.	A125004	Bearing Cup (Timken# HM624710)
21.	A14016	Valve Stem

# APRON CYLINDER 4"x13"

**Part #A125050**

**s.n. 20750 and above**

**effective 06/03**

If you have 3 capscrew headcap refer to the next page.

**1\* OLD STYLE**  
The older apron cylinder can be identified by 3/8" NPT ports & 3 bolts on the headcap of the gland.

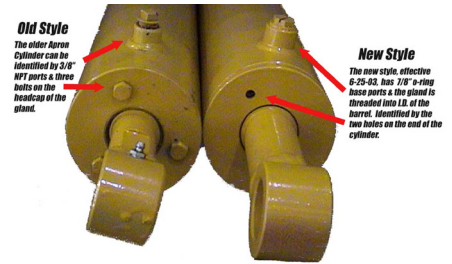

Old-New-Cylinder-III

**2\* NEW STYLE**  
The new style, effective 6/25/03, has 7/8" o-ring base ports & the gland is threaded into I.D. of the barrel. Identified by the 2 holes on the end of the cylinder.

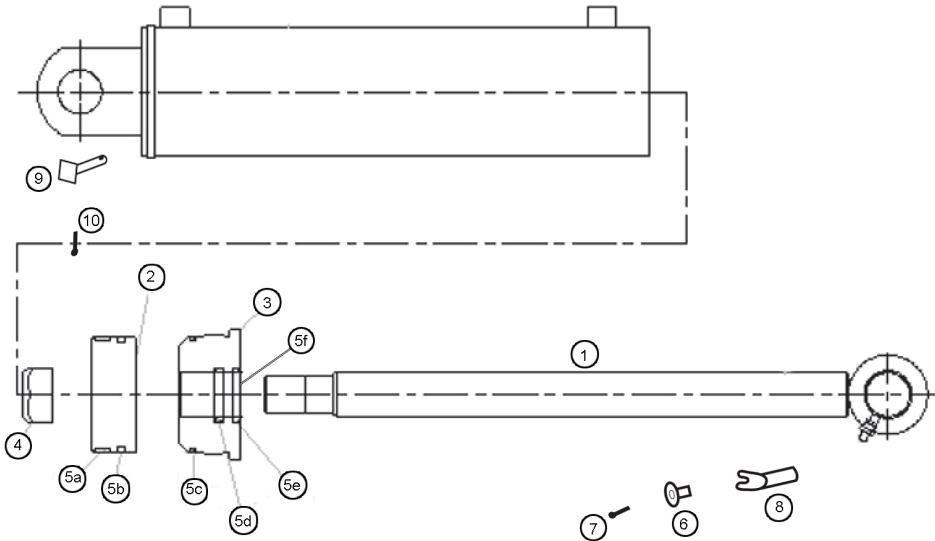

A-125050-III

ITEM	PART ITEM	DESCRIPTION
1	A125050-01	Rod 1-3/4" with welded eye
2	A125050-02	Piston
3	A125050-03	Gland, Threaded
4	A125050-04	Lock Nut, 1-1/8" NF
5	A125050-05	Seal Kit, a-f
	A125050-05a	Nylon Wear Ring
	A125050-05b	FSP Seal
	A125050-05c	O-Ring
	A125050-05d	Backup Washer
	A125050-05e	Hallite Rod Seal
	A125050-05f	Snap-in Rod Wiper
	A123362	Pin, 1-1/2" with slot for keeper bushing
	8602	Pin, Cotter 1/4" x 2" Zinc
	A123351	Bushing, retaining flange, 9/16" ID x 3/4" OD, 3/4" L
	A123363	Pin: 1-1/2" square head
	AFB-00015	HHCS 1/2" NC x 1-1/2" Gr. 8

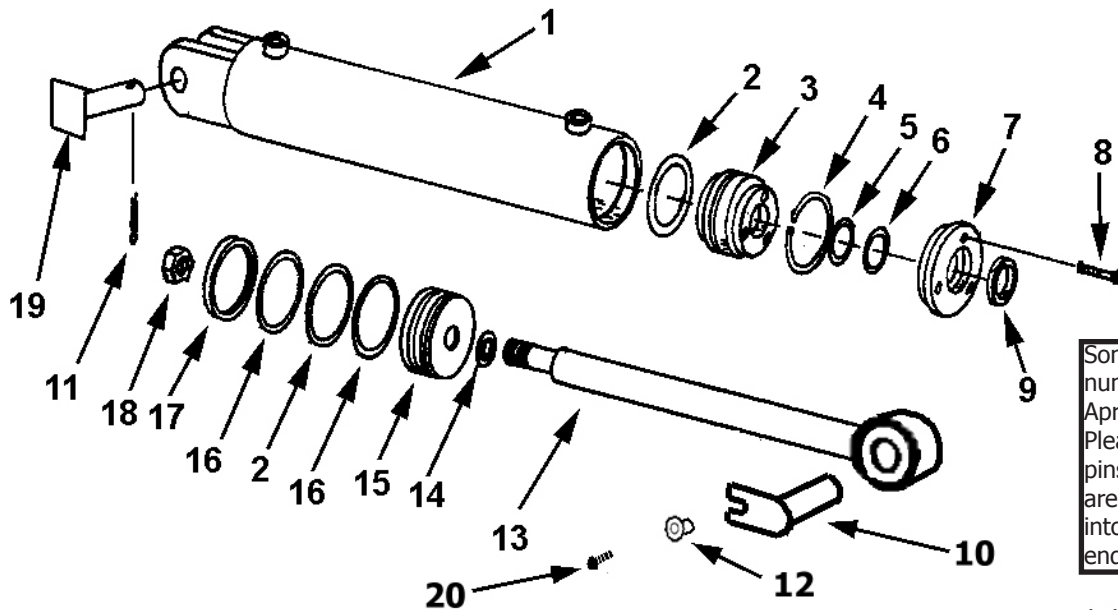

### IMPORTANT

Some units prior to this serial number were upgraded to a H.D. Apron Cylinder by the customer. Please determine if the cylinder pins are 1-1/2" diameter. If pins are 1" or 1-1/4" and is inserted into a thread block ear on the rod end please refer to page 21.

A-123365

## MODEL I-155 TS LEFT & RIGHT SIDE APRON CYLINDER 4 X 13 PART NO. A123365

KEY NO.	PART NO.	DESCRIPTION
1.	A123365-05	Cylinder Barrel
2.	A300H06	O-Ring: 4" OD x 3/16"
3.	A300H11	Head Gland
4.	A300H12	Retainer Ring
5.	A22H15	O-Ring: 1-1/2" ID x 1/8"
6.	A22H15A	Backup Washer: 1-1/2"
7.	A300H13	Gland Cap
8.	A22H18	Capscrew: 1/4" NC x 1"
9.	A22H17	Wiper Seal: 1-1/2" ID
10.	A123362	Pin, 1-1/2" with slot for keeper bushing
11.	8602	Pin, Cotter 1/4" x 2" Zinc
12.	A123351	Bushing, retaining flange, 9/16" ID x 3/4" OD, 3/4" L
13.	A123365-03	Rod, S/N 20497 + Welded Eye with 1-1/2" Hole
** If your unit has thread block type rod end see following page **		
14.	A45H05	Piston Gasket: 1"
15.	A300H07	Piston: 4" Dia.
16.	A300H05	Backup Washer: 4" OD
17.	A300H04	Cast Iron Ring: 4" OD
18.	A300H03	Piston Nut, 1" NF
19.	A123363	Pin: 1-1/2" square head
20.	AFB-00015	HHCS 1/2" NC x 1-1/2" Gr. 8
	A300H14B	Packing Kit, Containing:
	(1) A300H04	(1) A22H15
	(2) A300H05	(1) A22H15A
	(2) A300H06	(1) A22H17
	(1) A45H05	

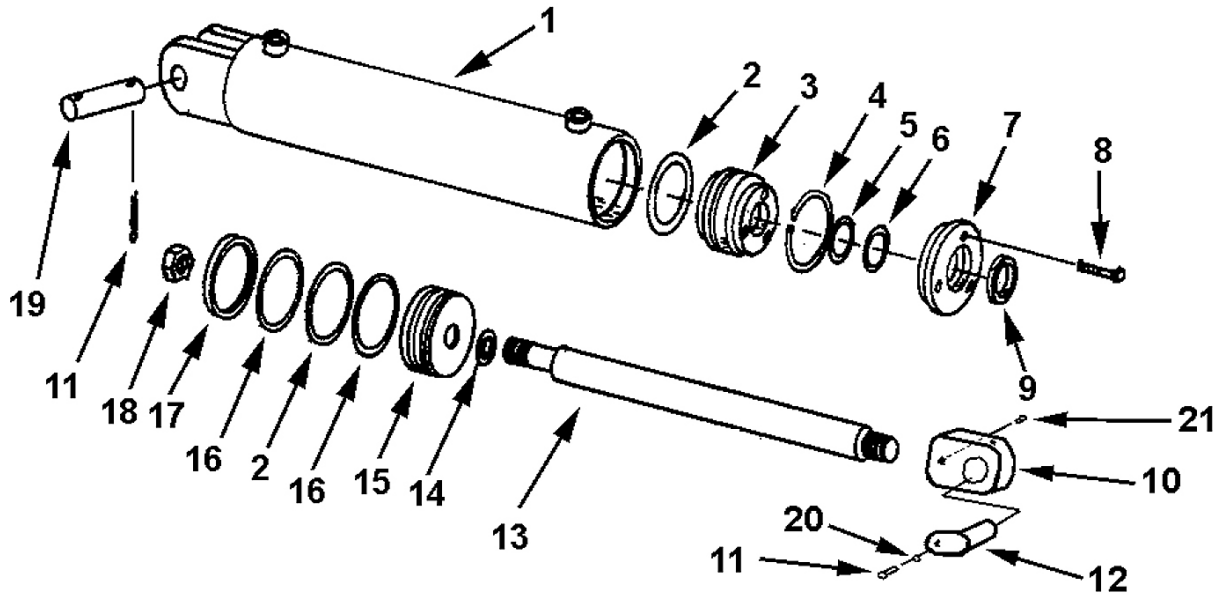

A-123319-ILL

**LEFT & RIGHT SIDE APRON CYLINDER 4 X 13**  
**PART NO. A123319**

KEY NO.	PART NO.	DESCRIPTION
1.	A175H01	Cylinder Barrel
2.	A300H06	O-Ring: 4" OD x 3/16"
3.	A300H11	Head Gland
4.	A300H12	Retainer Ring
5.	A22H15	O-Ring: 1-1/2" ID x 1/8"
6.	A22H15A	Backup Washer: 1-1/2"
7.	A300H13	Gland Cap
8.	A22H18	Capscrew: 1/4" NC x 1"
9.	A22H17	Wiper Seal: 1-1/2" ID
10.	A123345	Up to S/N 20458 -Block Type, 1" Hole
	A123310-16	S/N 20459 and Up - Block Type, 1-1/4" Hole
11.	AFB-00015	HHCS: 1/2 NC X 1-1/2"
12.	A123336	Up to S/N 20458 Pin: Tab Hd. w/Grs. Ftg. 1" x 3-5/8"
	A123347	S/N 20459 to 20496 Pin: Tab Hd. w/Grs. Ftg. 1-1/4" x 3-5/8"
13.	A175H02	Shaft: 1-1/2" Dia.
14.	A45H05	Piston Gasket: 1"
15.	A300H07	Piston: 4" Dia.
16.	A300H05	Backup Washer: 4" OD
17.	A300H04	Cast Iron Ring: 4" OD
18.	A300H03	Piston Nut, 1" NF
19.	A1217 E	Pin: 1" x 3-1/2" ETD-150
20.	8100	Lockwasher: 1/2"
21.	AFB-00062	Socket Screw: 3/8" NC - 3/4" with Brass Tip
	A300H14B	Packing Kit, Containing:
	(1) A300H04	(1) A22H15
	(2) A300H05	(1) A22H15A
	(2) A300H06	(1) A22H17
	(1) A45H05	

**IMPORTANT**

Some units prior to this serial number were upgraded to a H.D. Apron Cylinder by the customer. Please determine if the cylinder pins are 1-1/2" diameter (page 20). If pins are 1" or 1-1/4" (Key # 12) and is inserted into a thread block ear (Key # 10) on the rod end please refer to this page.



## LIFT CYLINDER 5 X 20"

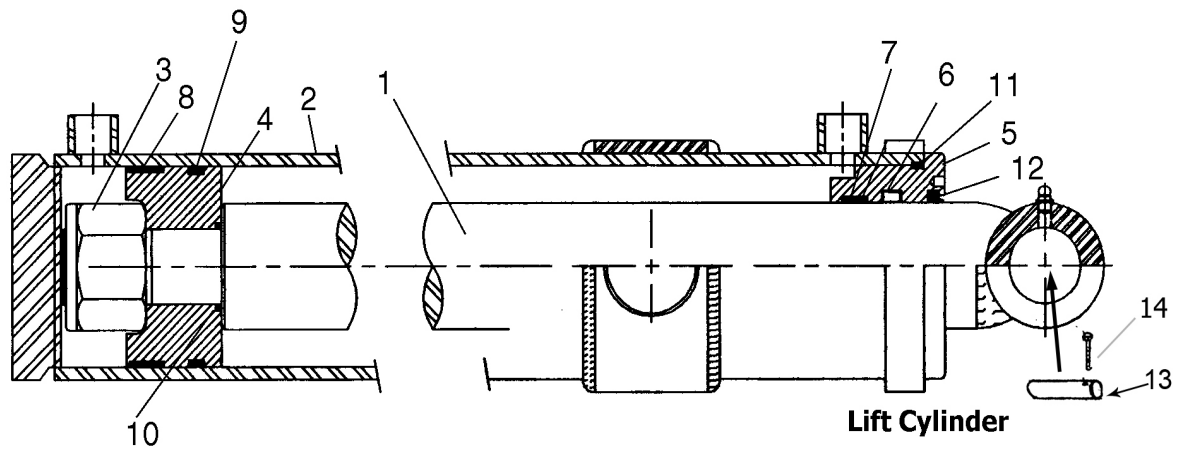

A-123326-III

### MODEL I-155 TS LIFT CYLINDER 5 X 20" PART NO. A123326

<b>KEY NO.</b>	<b>PART NO.</b>	<b>DESCRIPTION</b>
1.	A123326-1	Piston Rod: 2-1/2"
2.	A123326-2	Barrel Weldment
3.	A125159-34	1-3/4 NF Locknut
4.	A123324-4	Piston
5.	A123324-5	Gland
6.	A123324-6	Rod Seal
7.	A123324-3	Wear Band
8.	A123324-8	Wear Ring
9.	A123324-9	Piston Seal
10.	A123324-10	O-Ring
11.	A123324-11	O-Ring
12.	A123324-7	Rod Wiper
12.	AHS-00140	Seal Kit (Items 6-12)
13.	A123335	Pin, 2" x 10-1/2" lg.
14.	AFP-00001	Cotter Pin, 1-4" x 3"

**MODEL I-155 TS  
PUSHOFF CYLINDER 5 X 60"  
PART NO. A560H114A  
Upt ot S.N. 21458**

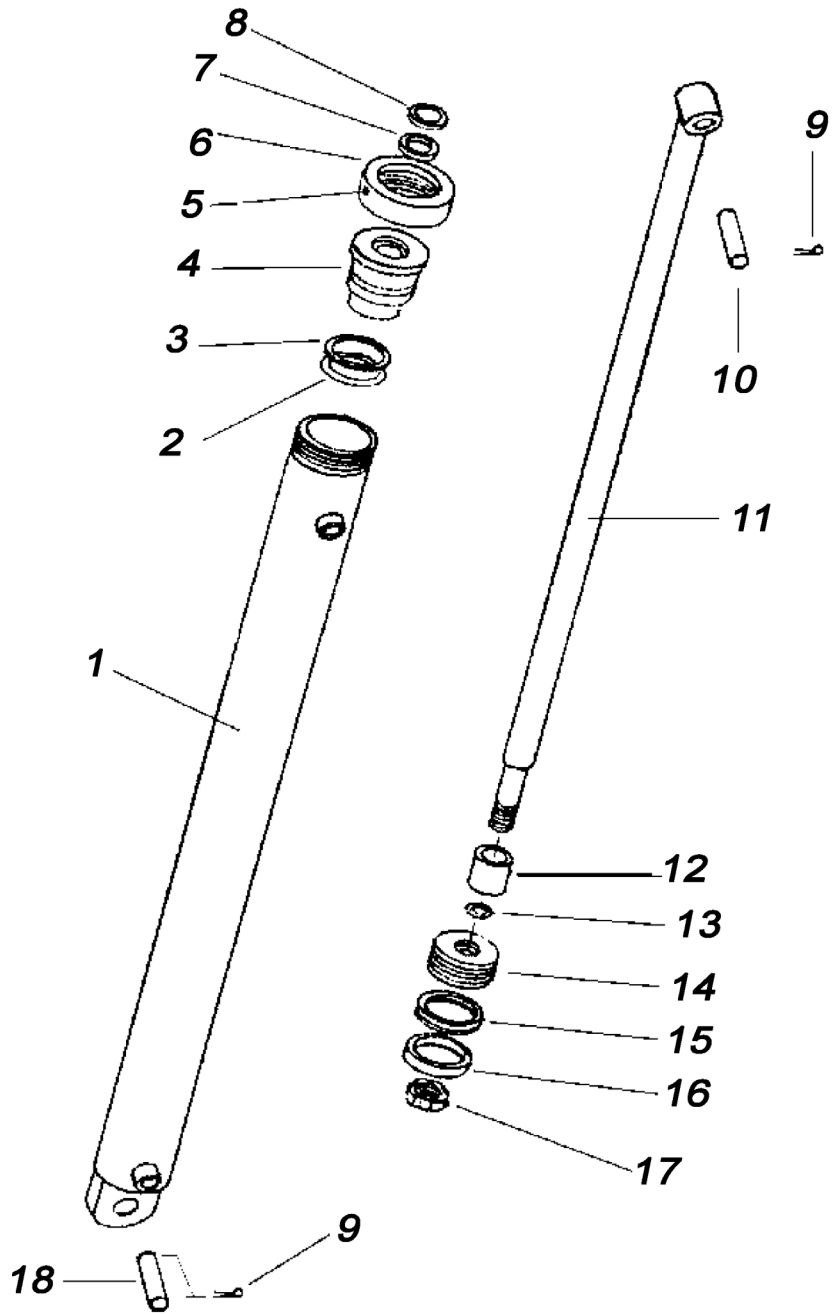

**A-560H114A-III**

**MODEL I-155 TS  
PUSHOFF CYLINDER 5 X 60"  
PART NO. A560H114A**

<b>KEY NO.</b>	<b>PART NO.</b>	<b>DESCRIPTION</b>
1.	A140H20	Barrel Assembly: 5" Bore
2.	A400H06	O-Ring: 5" OD X 4-1/2" ID
3.	A400H05	Back Up Washer: 5" OD X 4-1/2" ID
4.	A140H21	Head Gland: 5"
5.	AFB-00061	Set Screw: 3/8" NC
6.	A140H19	Collar
7.	A140H07	Shaft Seal: 2-1/2" ID X 3" OD OU-Cup
8.	A140H08	Wiper Seal: 2-1/2" ID X 2-15/16" OD
9.	8602	Cotter Pin: 1/4" X 2"
10.	A14033	Pin: 1-1/4" Dia. X 5" Lg.
11.	A140H27	Shaft: 2-1/2" Dia.
12.	A175H06	Spacer
13.	A22H15	O-Ring: 1-1/2" x 1-3/4" OD
14.	A140H22	Piston: 5"
15.	A140H24	Piston Seal: 5" OD X 4-1/4" ID
16.	A140H25	Wear Ring: 5" OD
17.	AFN-00018	Lock Nut: 1-1/2" NF
18.	A9024	Pin: 1-1/4" x 4-3/4"
	A140H28	Packing Kit: Containing:
		(1) A140H25            (1) A400H06
		(1) A140H07            (1) A140H08
		(1) A22H15            (1) A400H05
		(1) A140H24

**MODEL I-155 TS2**  
**PUSHOFF CYLINDER 5 X 60"**  
**PART NO. A125177**  
**S.N. 21459 And Up**

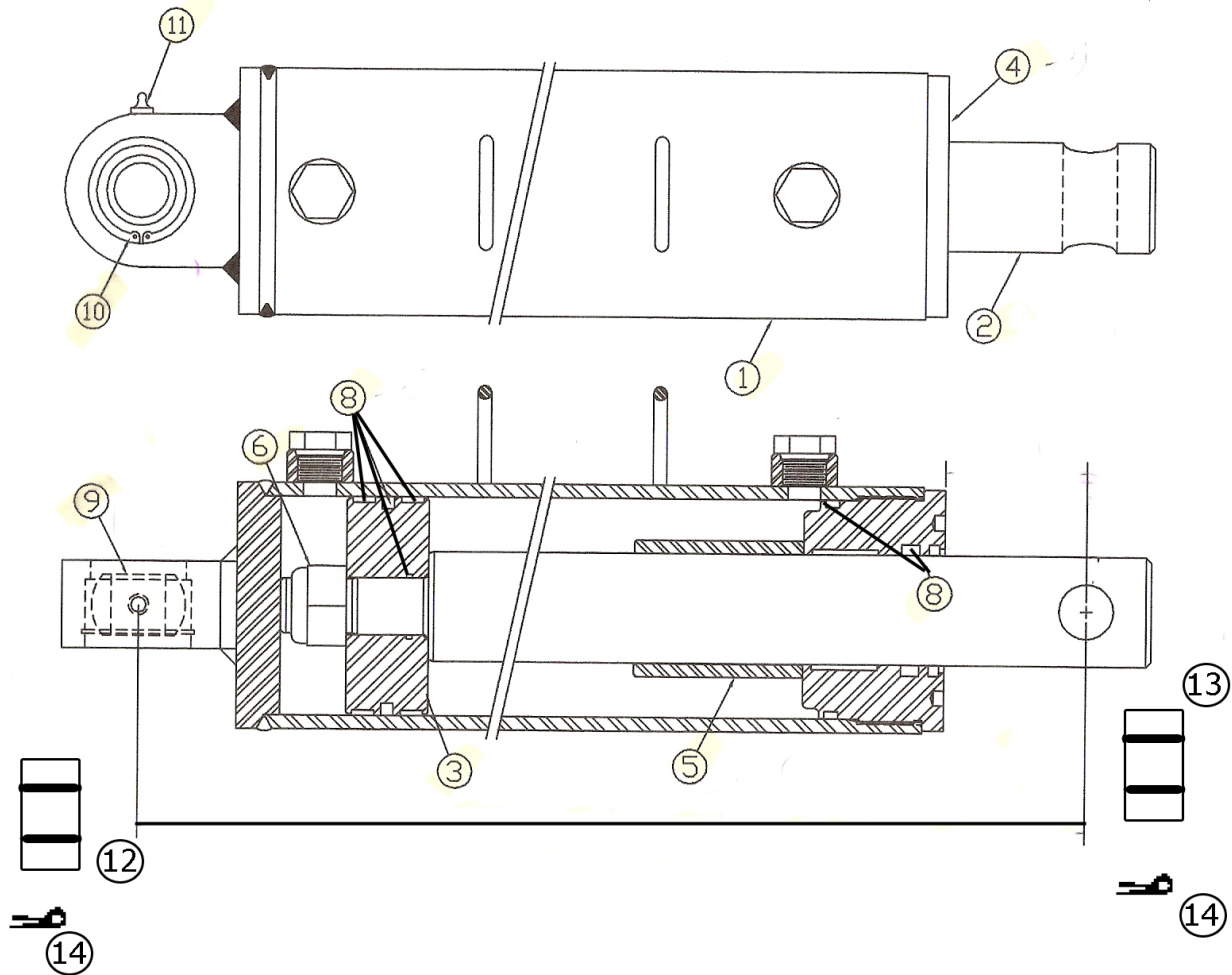

<b>KEY NO.</b>	<b>PART NO.</b>	<b>DESCRIPTION</b>
1.	A125177-10	Barrel Weldment (1)
2.	A125177-20	Shaft (1)
3.	A125177-30	Piston (1)
4.	A125177-31	Head (1)
5.	A125176-32	Spacer (1)
6.	A125175-33	1 1/4" Nylock Nut (1)
8.	A125177-40	Seal Kit (1)
9.	A125175-35	Bearing
10.	A125175-36	Snap Ring
11.	A125175-37	Grease Zerk (1)
12.	A9024	Pin 1-1/4 x 4-3/4 Lg
13.	A14033	Pin 1-1/4 x 5 Lg
14.	AFP-00001	Cotter Pin 1/4 x 2

## MODEL I-155 TS Nitrogen over Hydraulic Accumlator

<b>KEY NO.</b>	<b>PART NO.</b>	<b>DESCRIPTION</b>
1.	A155H67	Hose, 3/4" x 16" MORB with sweep
2.	A125009	Bracket, Welded with bolts
3.	A125005	Accumulator Cylinder

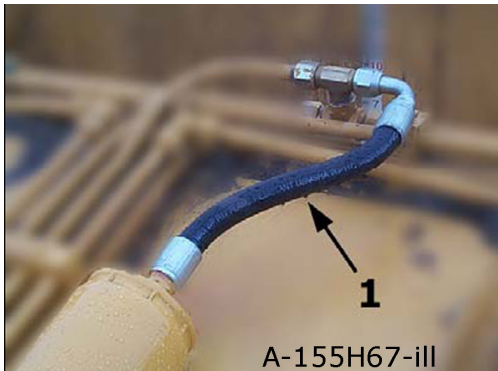

This Accumulator is rated at 4,000 psi and is pre-charged at the plant at 2,800 psi. Any circuit pressure above 2,800 will bleed off into this accumulator until it reaches 2.11 gallons of hydraulic oil displacement. This accumulator can be recharged with nitrogen however the accumulator is NOT REBUILDABLE.

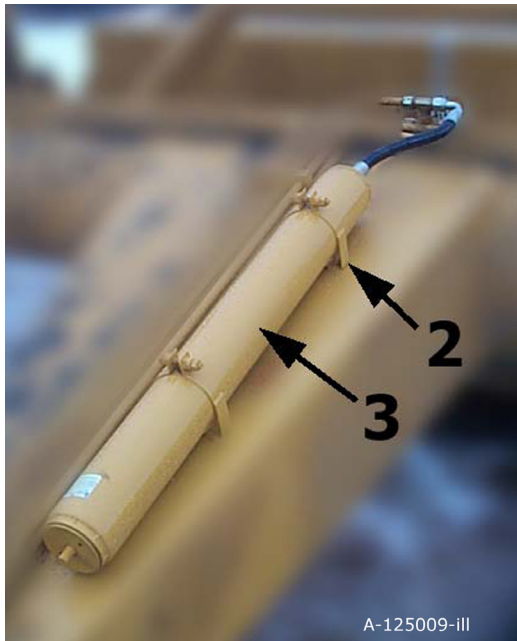

## MODEL I-155 TS DECALS

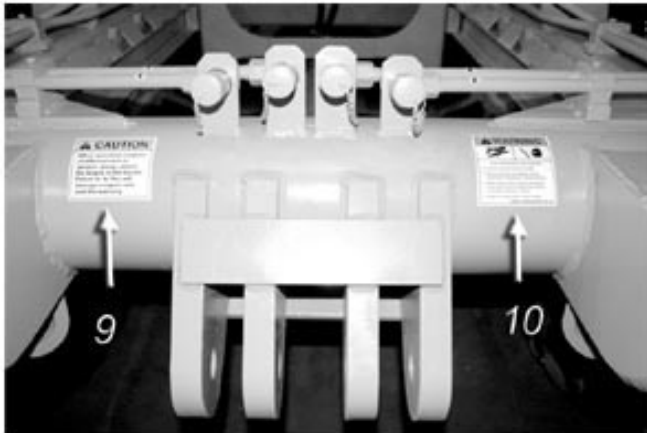
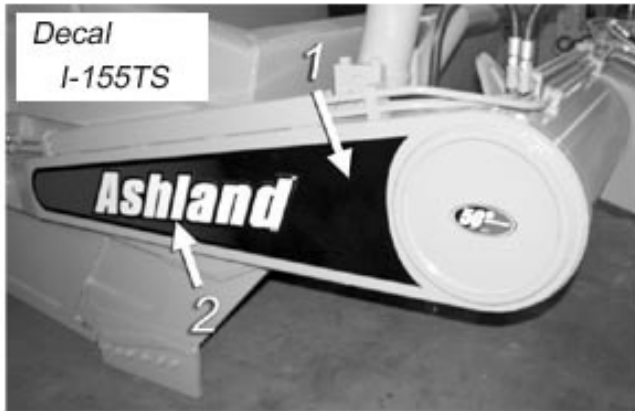

KEY	PART NO.	DESCRIPTION	AMT REQUIRED/SCRAPER
1.	ADS-00003	Decal Blade Wedge, Gradient	2 required/scraper
2.	ADS-00001	Decal Ashland Logo, Large	2 required/scraper
3.	ADS-00011	Decal Pinch Point,	4 required/scraper
4.	ADS-00004	Decal I-155 Numerals only	2 required/scraper
5.	ADS-00005	Decal "TS"	2 required/scraper
6.	ADS-STRIPEKIT	Decal Stripes,	2 required/scraper
7.	A123286	Decal Apron opening	1 required/scraper
9.	ADS-00015	Decal "when pulling in tandem"	1 required/scraper
10.	750464	Decal "Hydraulic Pressure"	2 required/scraper
11.	ADS-00002	Decal Small "Ashland"	1 required/scraper

Hydraulic Plumbing  
I-155TS  
Front Unit, Dual Hydraulic,  
Front Section

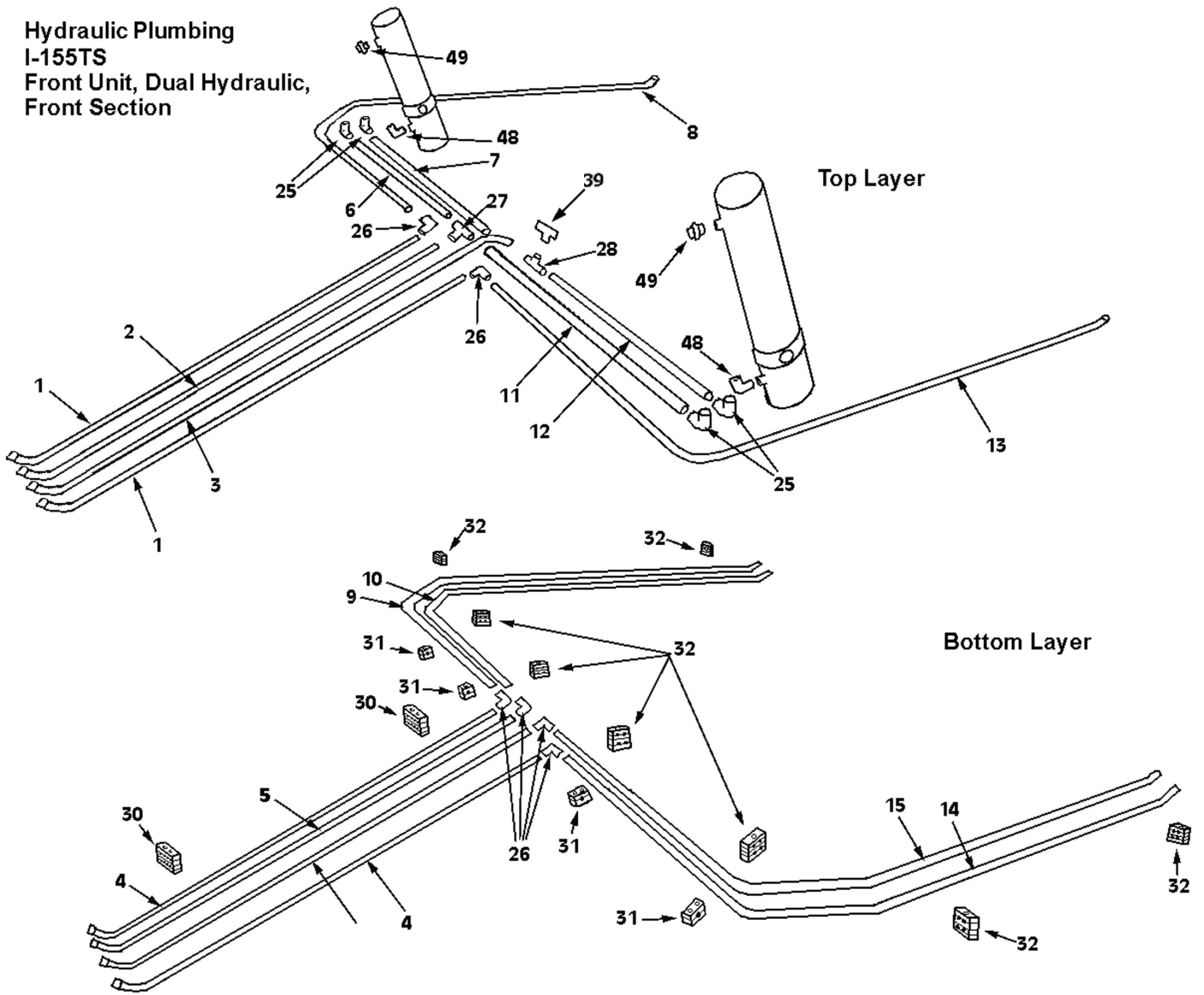

I-155-plumb-1-ill

*MOD-155TS-F-3HYD PARTIAL: Field Installation converting Front unit to 3-circuits*

up to S. N. 20495

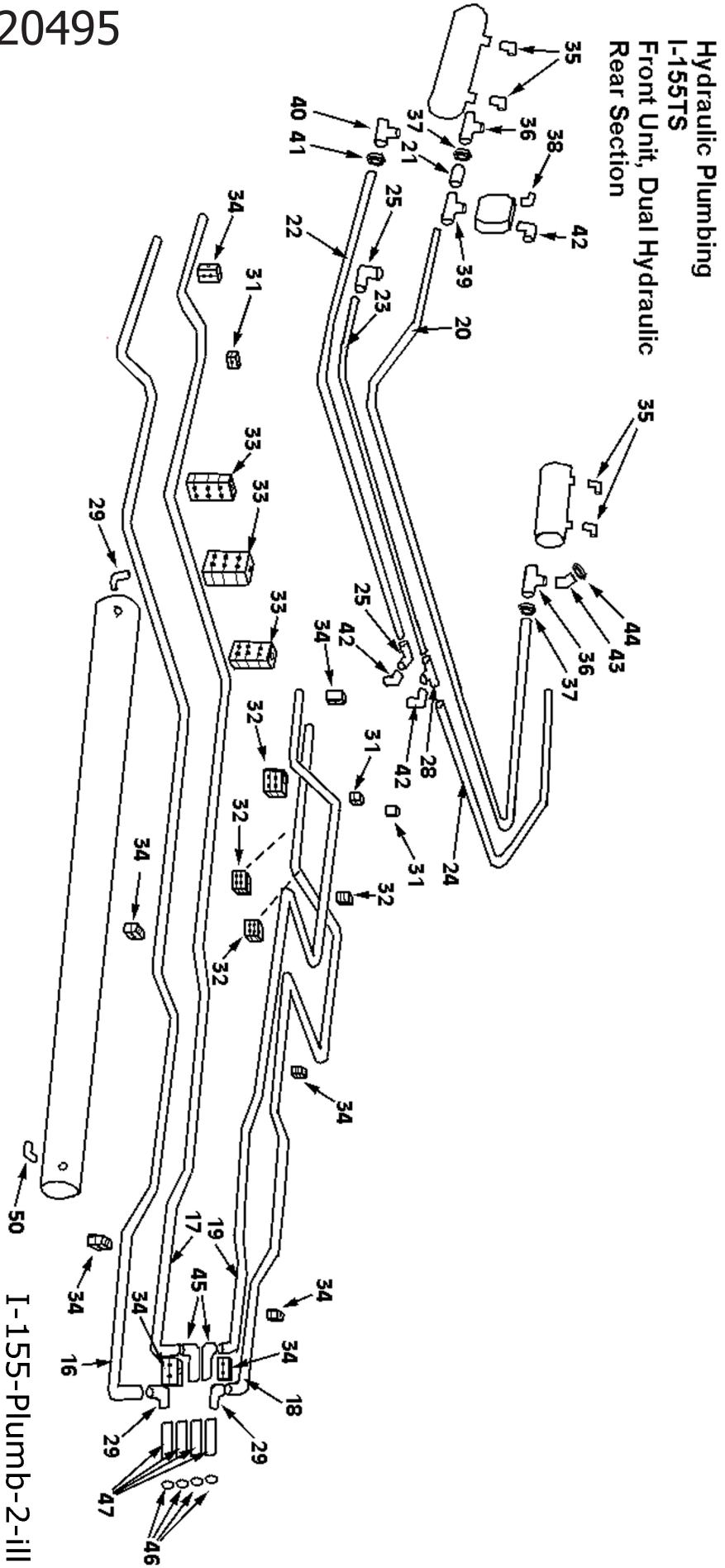



S. N. 20496 and up

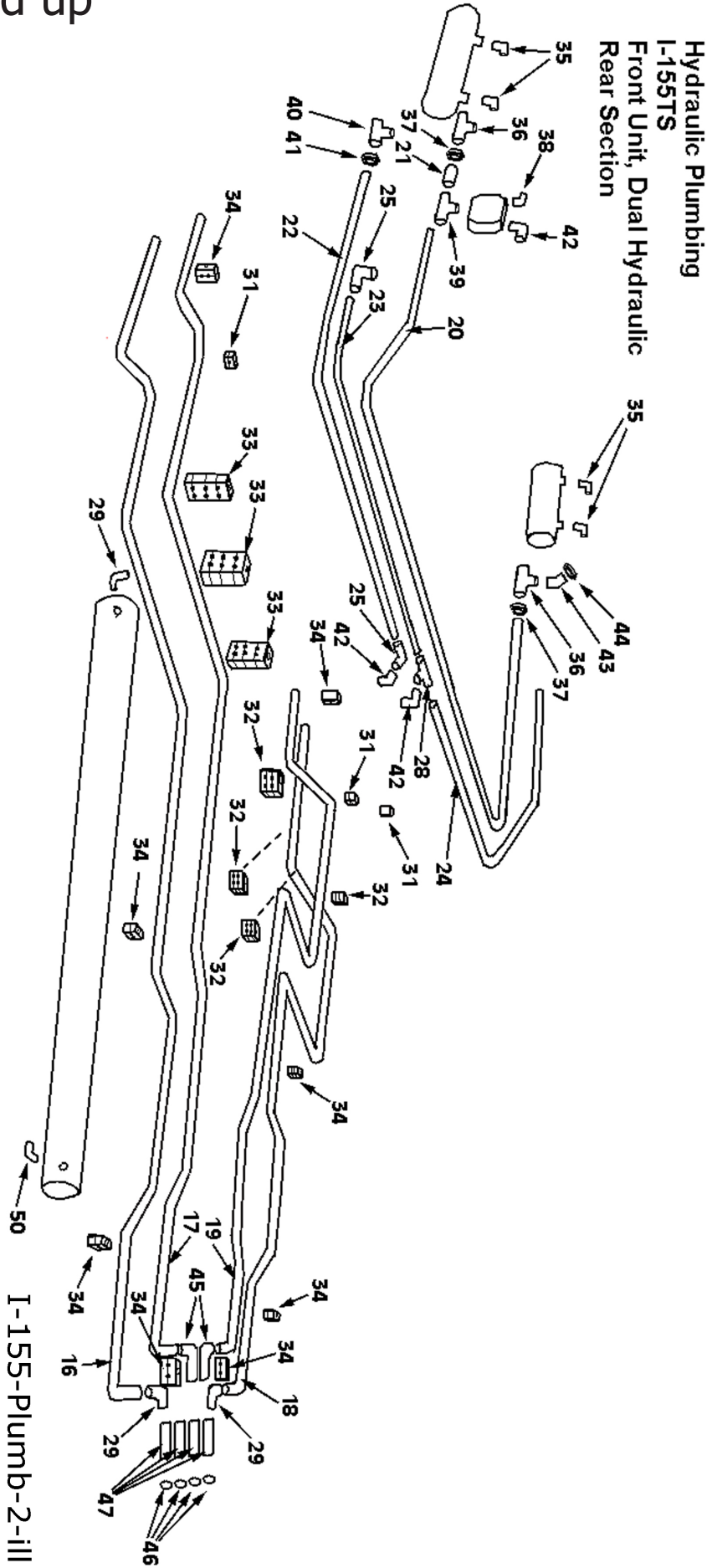

# up to S. N. 20495

Hydraulic Plumbing  
I-155TS  
Rear Unit  
Front Section

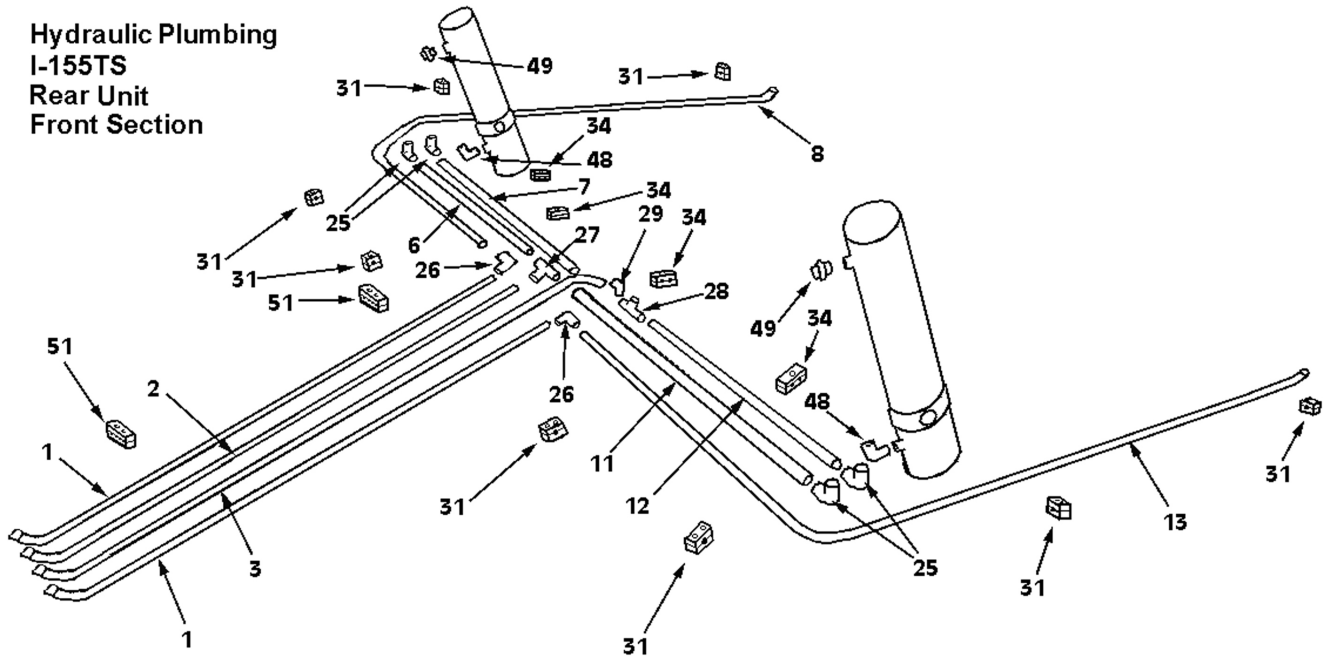

Hydraulic Plumbing  
I-155TS  
Rear Unit  
Rear Section

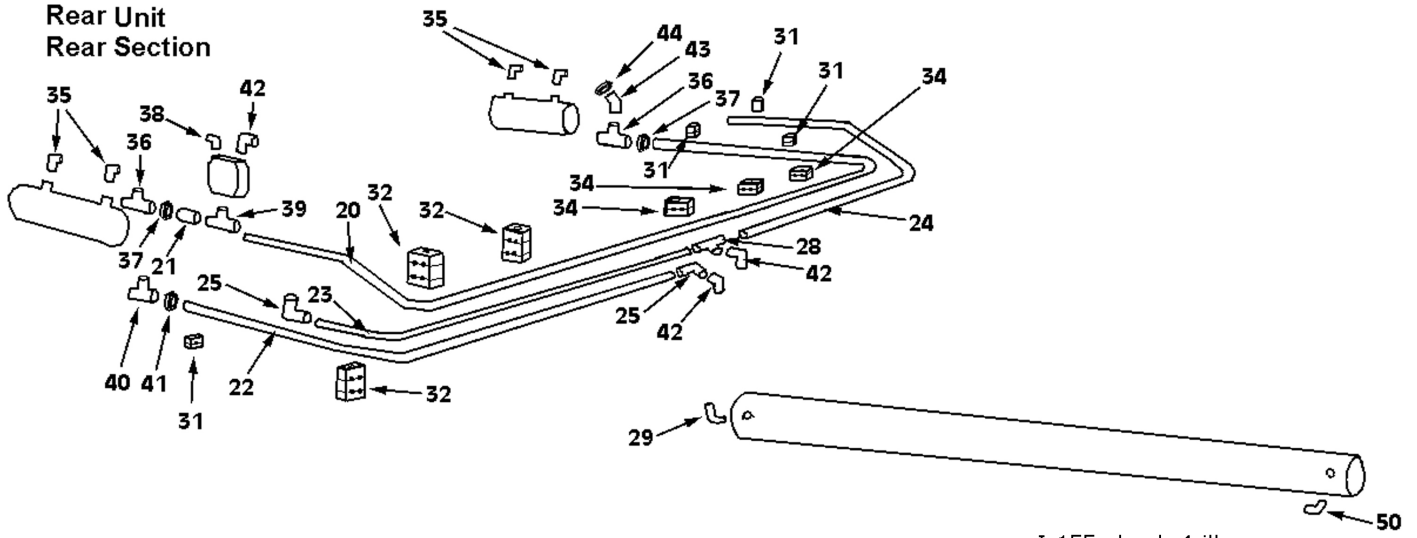

I-155-plumb-4-ill

# S. N. 20496 and up

Hydraulic Plumbing  
I-155TS  
Rear Unit  
Front Section

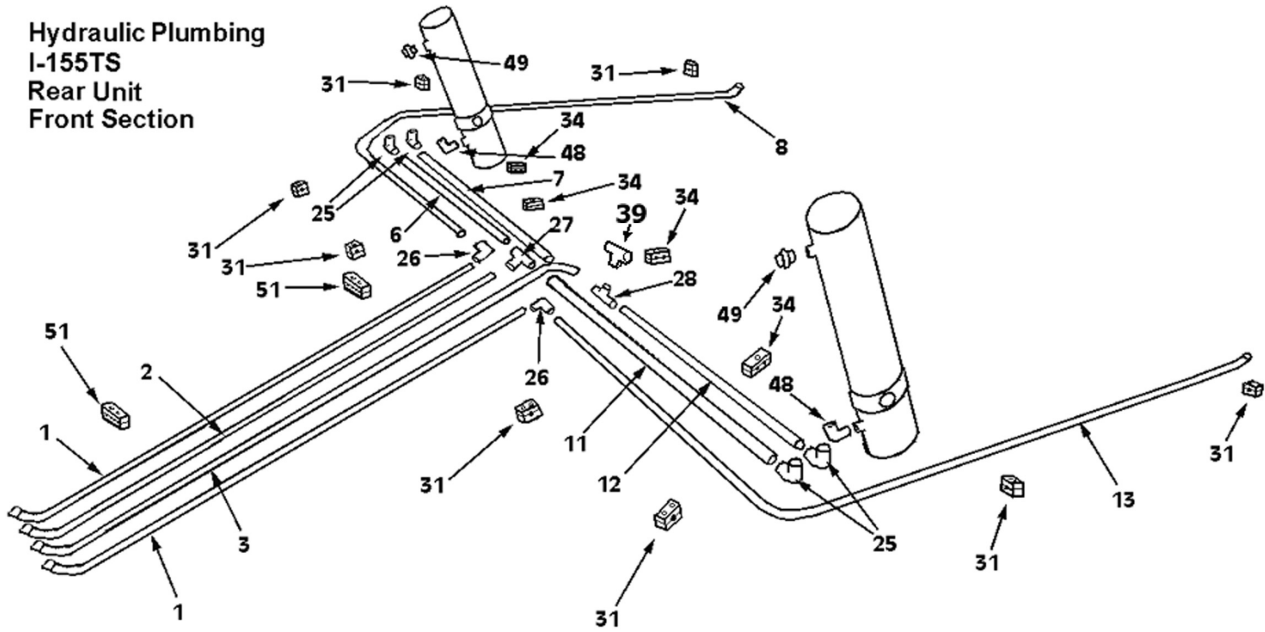

Hydraulic Plumbing  
I-155TS  
Rear Unit  
Rear Section

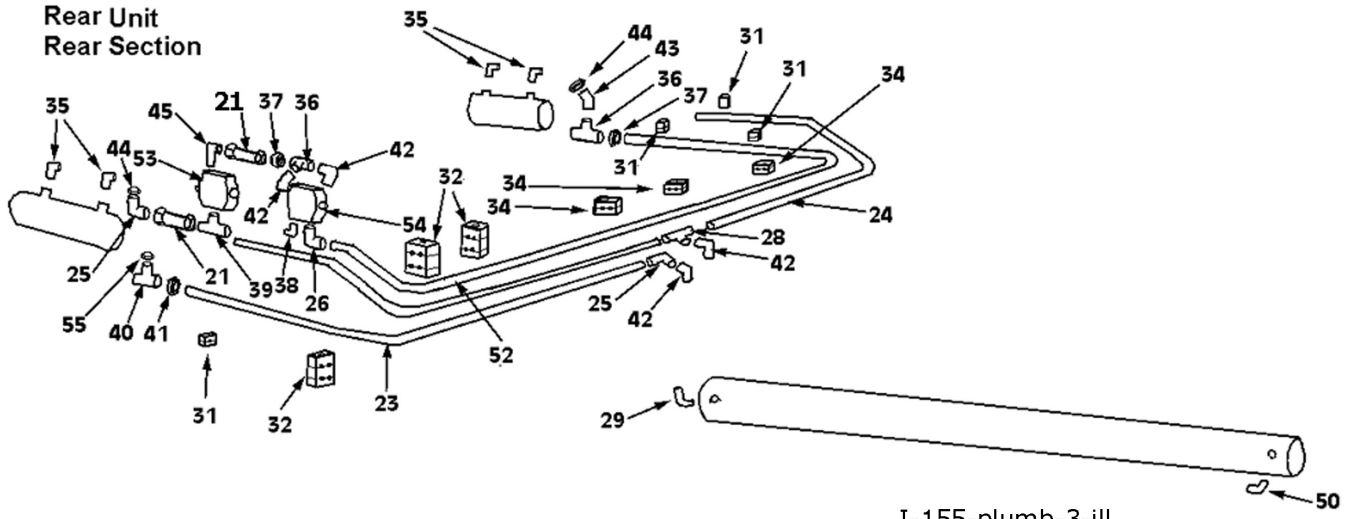

I-155-plumb-3-ill

## PARTS LIST - HYDRAULIC PLUMBING - MODEL I-155TS

Key No.	Part No.	Description
1	A155H01	Tubing, Front, Top, Far Right and Far Left
2	A155H02	Tubing, Front, Top, 2nd From Right
3	A155H03	Tubing, Front, Top, 2nd From Left
4	A155H04	Tubing, Front, Bottom, Outside
5	A155H05	Tubing, Front, Bottom, Inside
6	A155H06	Tubing, Top, Right Side
7	A155H07	Tubing, Top, Right Side
8	A155H08	Tubing, Top, Right Arm
9	A155H09	Tubing, Bottom, Outer, Right Arm
10	A155H10	Tubing, Bottom, Inner, Right Arm
11	A155H11	Tubing, Top, Left Side
12	A155H12	Tubing, Top, Left Side
13	A155H13	Tubing, Top, Left Arm
14	A155H14	Tubing, Bottom, Outer, Left Arm
15	A155H15	Tubing, Bottom, Inner, Left Arm
16	A155H16	Tubing, Back, Outer Right
17	A155H17	Tubing, Back, Inner Left
18	A155H18	Tubing, Back, Outer Left
19	A155H19	Tubing, Back, Inner Right
20	A155H20	Tubing, Wraps Around Back of Bowl
21	A155H21	Tubing, Short, Left Side of Bowl
22	A155H22	Tubing, Top, Around Left Side of Bowl
23	A155H23	Tubing, Bottom, Around Left Side of Bowl
24	A155H24	Tubing, Around Right Side of Bowl
25	AHA-00009	ADAPTER: 90 DEG. 3/4 M JIC X 1/2 F NPT
26	AHA-00019	ADAPTER: 90 DEG. 3/4 M JIC X 3/4 M JIC
27	AHA-00022	ADAPTER: T 3/4 M JIC X 3/4 M JIC X 3/4 M JIC
28	AHA-00015	ADAPTER: T 3/4 M JIC X 3/4 F NPT X 3/4 M JIC
29	AHA-00018	ADAPTER: 90 DEG. 3/4 M JIC X 3/4 M NPT
30	AHL-00004	CLAMP, HYD TUBING: 4 TUBE
31	AHL-00001	CLAMP, HYD TUBING: 1 TUBE
32	AHL-00022	CLAMP, HYD TUBING: 2 TUBE STACKING
33	AHL-00022 (2)	CLAMP, HYD TUBING: 3 TUBE STACKING
34	AHL-00002	CLAMP, HYD TUBING: 2 TUBE
35	A45H07	ADAPTER: 90 DEG. SWIVEL 3/8 M NPT X 1/2 F NPT
36	AHA-00020	ADAPTER: T 3/4 F NPT X 3/4 F NPT X 3/4 F NPT
37	AHA-00006	ADAPTER: STR. 3/4 M JIC X 3/4 M NPT
38	A22H03	ADAPTER: 90 DEG. SWIVEL 3/8 M NPT X 3/8 F NPT
39	A175H17	ADAPTER: T 3/4 M JIC X 3/4 M NPT X 3/4 M JIC
40	AHA-00014	ADAPTER: T 1/2 F NPT X 1/2 F NPT X 1/2 F NPT
41	AHA-00005	ADAPTER: STR. 3/4 M JIC X 1/2 M NPT
42	AHA-00010	ADAPTER: 90 DEG. 3/4 M NPT X 3/4 F NPT
43	AHA-00021	ADAPTER: 45 DEG. 3/4 F NPT X 3/4 M NPT
44	AHA-00017	ADAPTER: HEX REDUCER BUSHING 3/4 M NPT X 1/2 F NPT
45	AHA-00030	ADAPTER: 90 DEG. 3/4 M JIC X 3/4 M NPT EXTRA LONG
46	AHF-00025	DUST CAPS
47	AHF-00023	FEMALE QUICK COUPLERS
48	AHA-00026	ADAPTER: 90 DEG. 1-1/16 MORB X 3/4 F NPT
49	AHA-00037	ADAPTER: STR. SWIVEL 1-1/16 MORB X 3/4 F NPT
50	A101H77	ADAPTER: 90 DEG. SWIVEL 3/4 M NPT X 3/4 F NPT
51	AHL-00004	CLAMP, HYD TUBING: 4 TUBE
52	A155H25	Tubing, Around Left Side of Bowl
53	A101H48	Counterbalance Valve
54	A101H47	Sequencing Valve
55	AHA-00025	ADAPTER: HEX REDUCER BUSHING 1/2 M NPT X 3/8 F NPT

up to S. N. 20495

Hydraulic Plumbing - Hoses  
I-155TS  
Front Unit, Dual Hydraulic

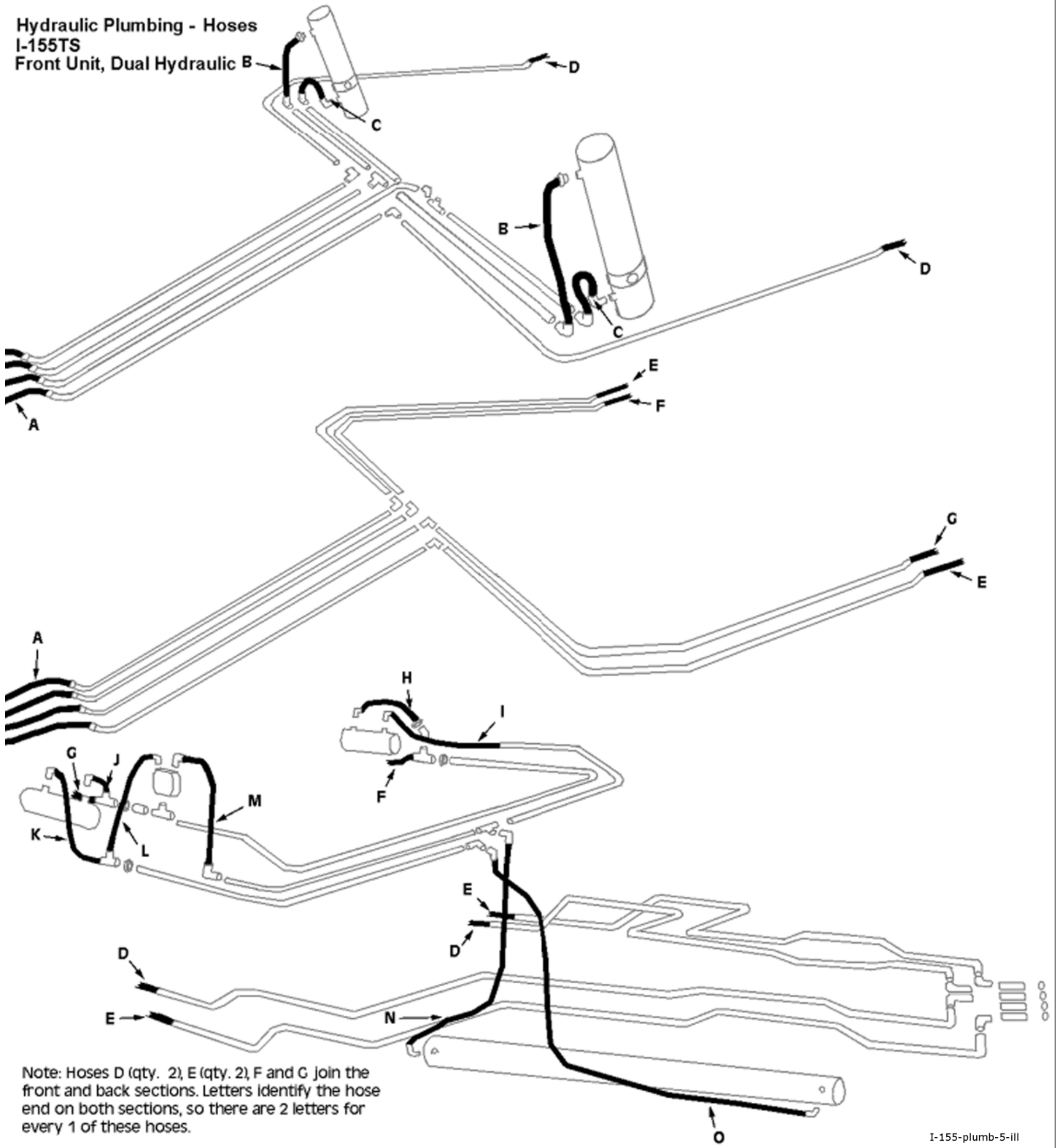

Note: Hoses D (qty. 2), E (qty. 2), F and G join the front and back sections. Letters identify the hose end on both sections, so there are 2 letters for every 1 of these hoses.

# S. N. 20496 and up

## Hydraulic System Hoses I-155TS

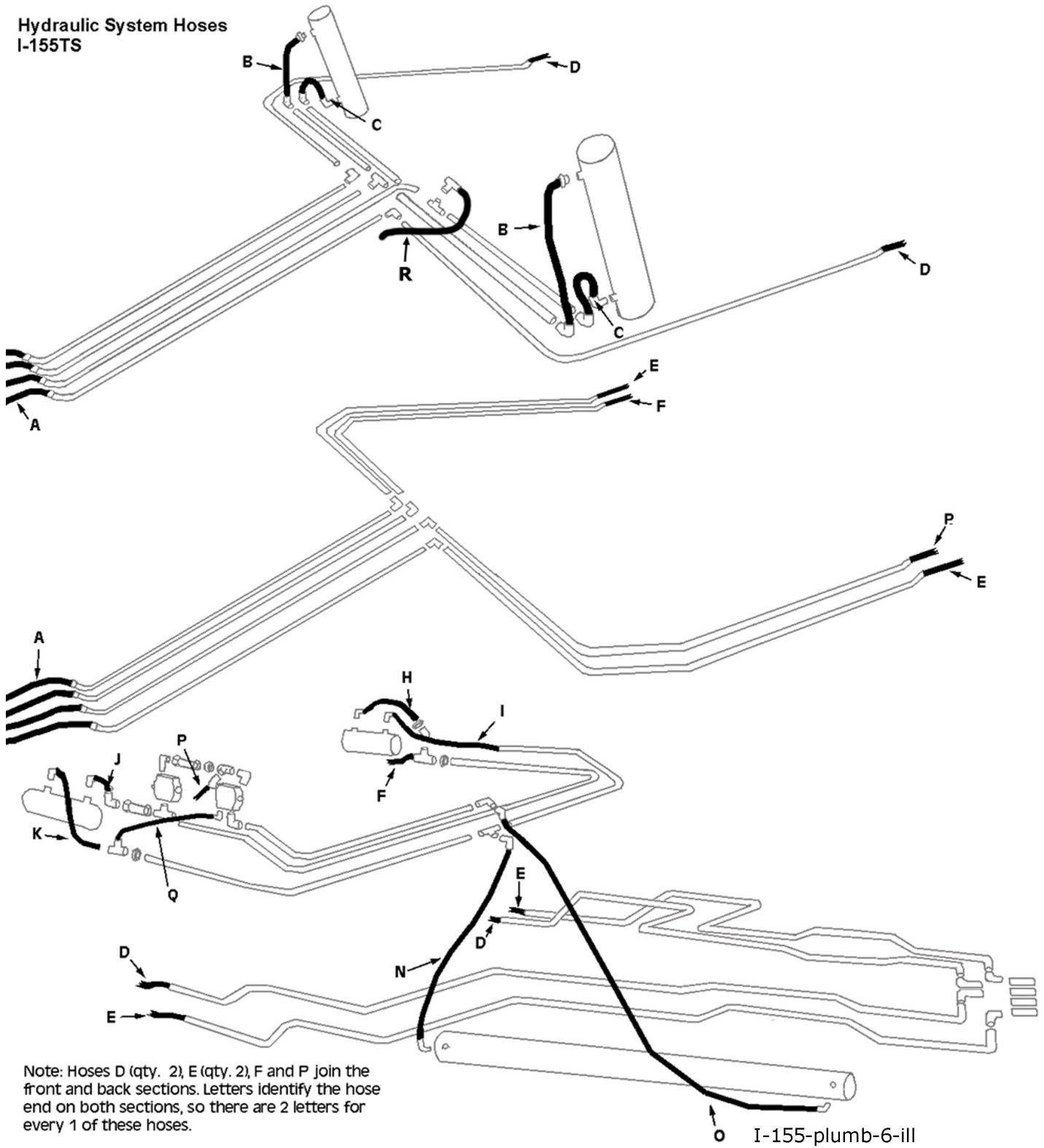

up to S. N. 20495

Hydraulic Plumbing - Hoses  
I-155TS  
Rear Unit

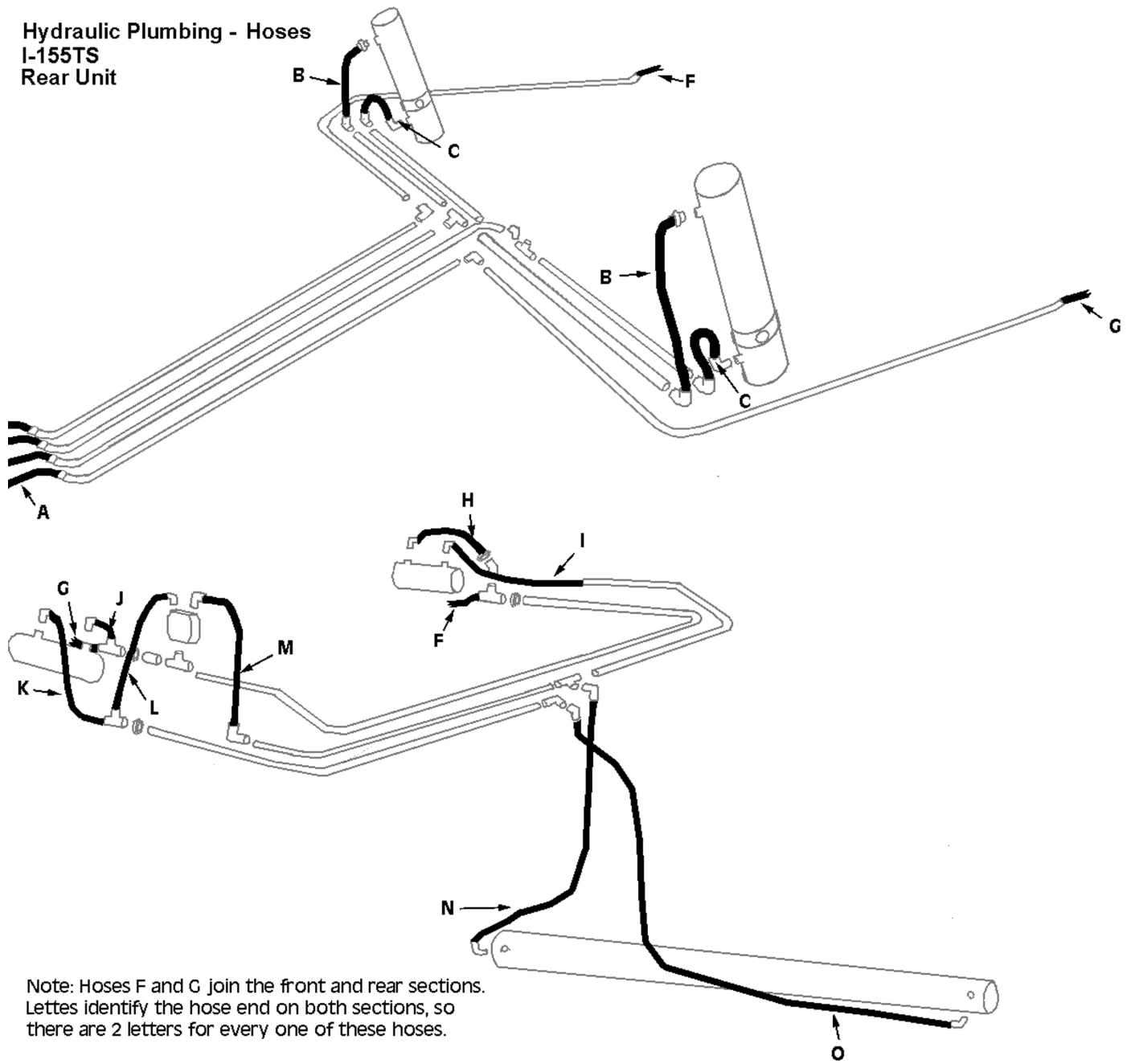

Note: Hoses F and G join the front and rear sections.  
Lettes identify the hose end on both sections, so  
there are 2 letters for every one of these hoses.

I-155-plumb-7-ill

# S. N. 20496 and up

Hydraulic System Hoses  
I-155TS  
Rear Unit

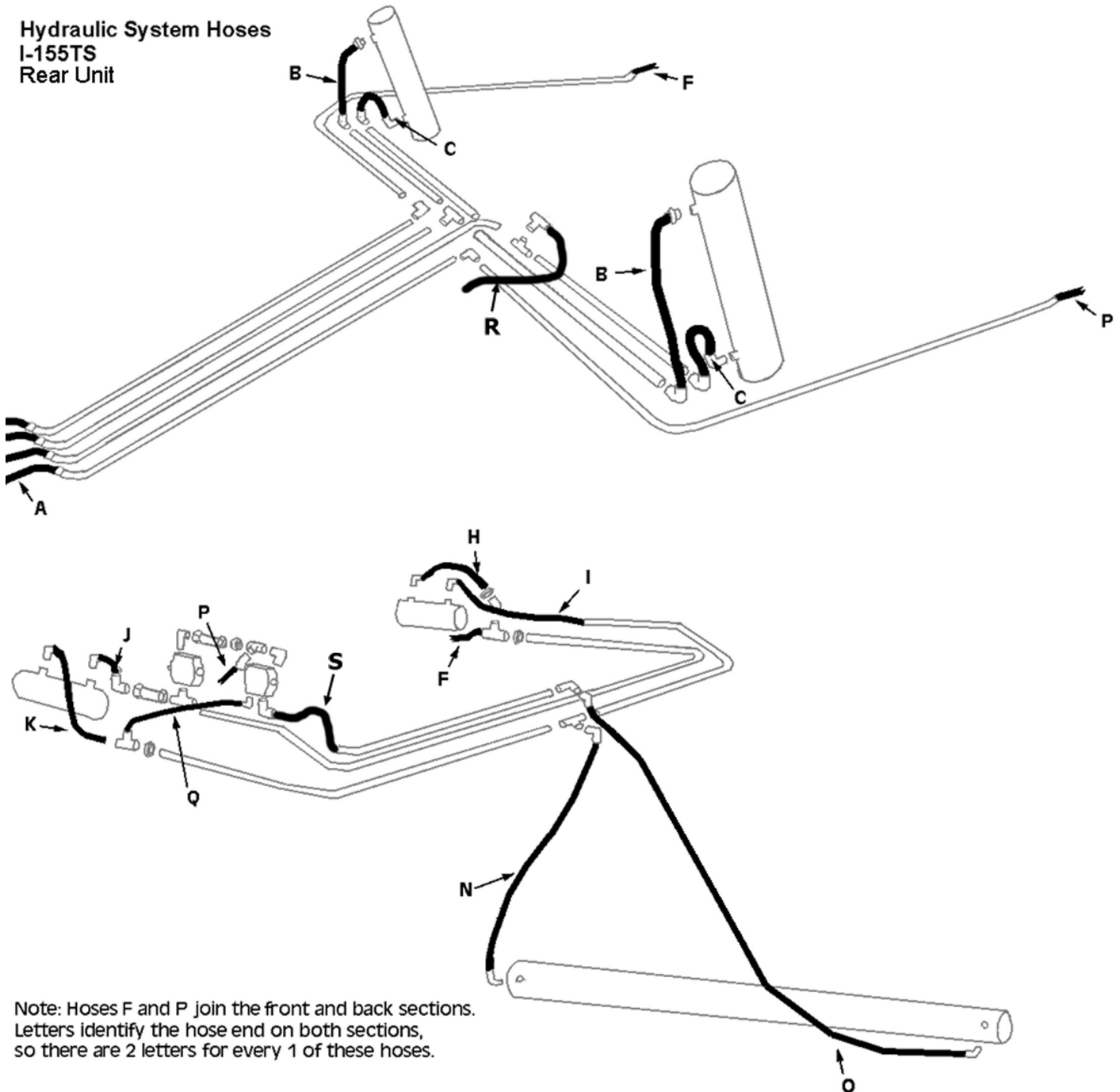

Note: Hoses F and P join the front and back sections.  
Letters identify the hose end on both sections,  
so there are 2 letters for every 1 of these hoses.

I-155-Plumb-8-ill.



## PARTS LIST - HYDRAULIC PLUMBING - HOSES - MODEL I-155TS

Key No.	Part No.	Description
A	A155H50	3/4" x 75" Long, M JIC, M NPT, Double Braid High Pressure Hose
B	A155H51	3/4" x 22" Long, M NPT, M NPT, Double Braid High Pressure Hose
C	A155H52	3/4" x 28" Long, M NPT, M NPT, Double Braid High Pressure Hose
D	A155H53	3/4" x 36" Long, M JIC, M JIC, Double Braid High Pressure Hose
E	A155H54	3/4" x 33" Long, M JIC, M JIC, Double Braid High Pressure Hose
F	A155H55	3/4" x 43 3/4" Long, M JIC, M NPT, Double Braid High Pressure Hose
G	A155H56	3/4" x 41 1/4" Long, M JIC, M NPT, Double Braid High Pressure Hose
H	A155H57	1/2" x 30" Long, M NPT, M NPT, Single Braid High Pressure Hose
I	A155H58	1/2" x 20" Long, M JIC, M NPT, Single Braid High Pressure Hose
J	A155H59	1/2" x 16" Long, M NPT, M NPT, Single Braid High Pressure Hose
K	A155H60	1/2" x 30" Long, M NPT, M NPT, Single Braid High Pressure Hose
L	A155H61	3/8" x 15" Long, M NPT, M NPT, Single Braid High Pressure Hose
M	A155H62	3/4" x 21" Long, M NPT, M NPT, Double Braid High Pressure Hose
N	A155H63	3/4" x 18" Long, M NPT, F JIC, Double Braid High Pressure Hose
O	A155H64	3/4" x 79" Long, M NPT, M NPT, Double Braid High Pressure Hose
P	A155H65	3/4" x 60" Long, M JIC, M NPT, Double Braid High Pressure Hose
Q	A155H66	3/8" x 22" Long, M NPT, M NPT, Single Braid High Pressure Hose
R	A155H67	3/4" X 16" Long MORB, 90 Deg. Long Sweep MJIC
S	A155H68	3/4 x 28" Long MNPT, MNPT

# SEQUENCE VALVE

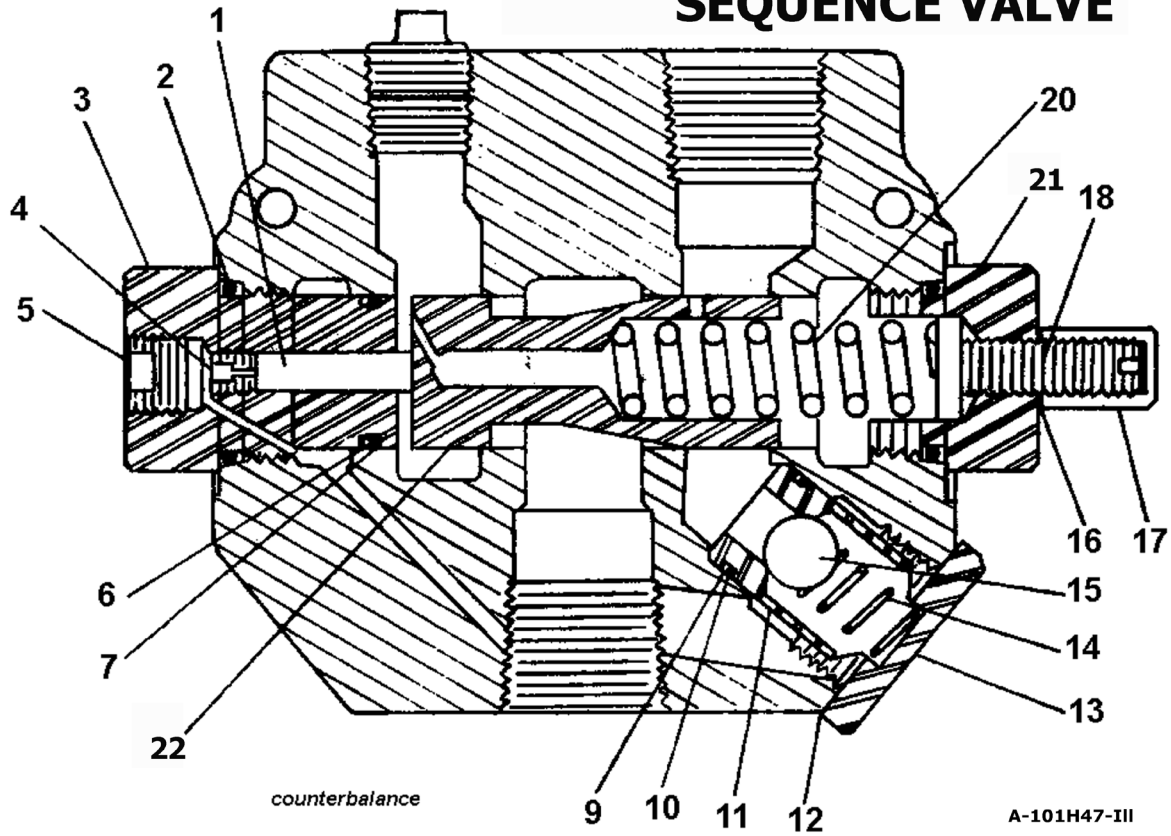

SEQUENCE VALVE PART #A101H47

# COUNTERBALANCE

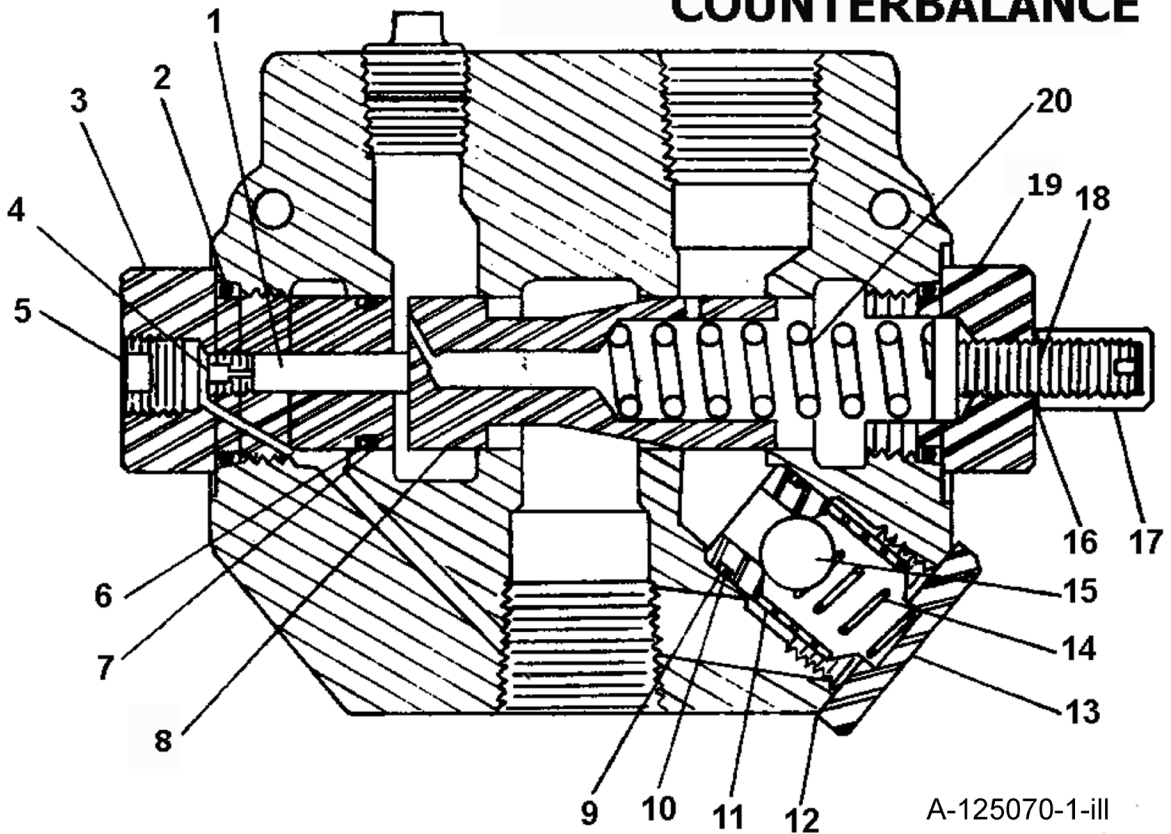

COUNTERBALANCE VALVE PART #A101H48

# SEQUENCE AND COUNTERBALANCE VALVE PARTS LIST

## SEQUENCE VALVE PART #A101H47 COUNTERBALANCE VALVE PART #A101H48

<b>KEY #</b>	<b>PART NO.</b>	<b>DESCRIPTION</b>
1	A101H49	Piston
2	A101H50	O-ring
3	A101H51	External pilot plug
4	A101H52	Orifice
5	A101H53	Plug
6	A101H54	O-ring
7	A101H55	Backup washer
*8	A101H56	Metering spool
9	A101H57	Backup washer
10	A101H58	O-ring
11	A101H59	Check seat
12	A101H60	Aluminum washer
13	A101H61	Check plug
14	A101H62	Check spring
15	A101H63	Check ball
16	A101H64	Aluminum washer
17	A101H65	Acorn nut
18	A101H66	Adjusting screw
19	A101H67	Adjusting plug - RD1075 CB
20	A101H68	Metering spring
21	A101H69	Adjusting Plug - RD1075 SM
22	A101H70	Metering Spool
*	A101H71	Valve body
	AHS-00002	Seal Kit

\* NOT SOLD SEPARATELY

**IMPORTANT:** This Hyd. Manifold was intergrated into production April, 2006  
It replaces A125070 valve.  
For older machines see master parts book on Ashlandind.com.

**HYDRAULIC MANIFOLD ASSEMBLY**  
**A125174**  
**S.N. 21403 & above**  
**SETTING THE APRON AND PUSHOFF VALVE**

The manifold block containing the pushoff sequence valve cartridge and apron sequence valve cartridge is used to control two hydraulic circuits with one hydraulic remote. when the tractor hydraulic remote is activated, oil flows first to the apron cylinders until they are fully extended. Once the cylinders are fully extended, the apron circuits' hydraulic pressure begins to increase. Once the pressure threshold is surpassed (which is adjustable. See adjustment section), the sequence valve diverts the oil flow to the pushoff's hydraulic circuit. Once the push off is completely extended the operator then reverses the tractors hydraulic remote. The counterbalance valve will hold the apron open until the push off is fully retracted. The Apron sequence valve then opens and allows the apron to close.

**Setting the valves:**

**STEP 1 PUSHOFF SEQUENCE VALVE**

Loosen the lock nut (9/16") on the sequence valve cartridge. Turn the setscrew (4mm) clockwise until the front apron rises before the push-off begins to advance. (Earth-mover should be empty) Turn the adjustment screw an additional 1/4 turn clockwise and tighten jam nut.

**STEP 2 Counter Balance VALVE**

Loosen the lock nut (9/16") on the counterbalance valve cartridge. Turn the set-screw (4mm) counter-clockwise until the apron holds in a raised position while rear gate is being retracted. Turn adjustment screw an additional 1/4 turn, tighten jam nut. DO NOT tighten adjusting screw more than necessary.

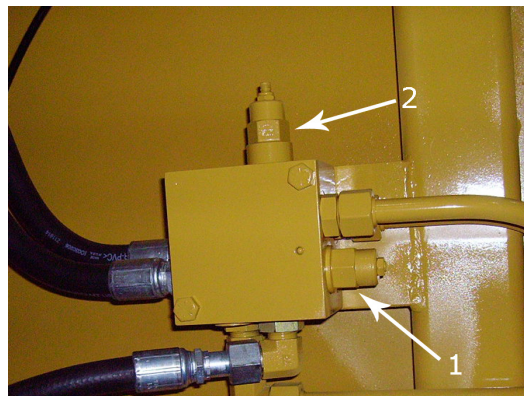

<b>ITEM #</b>	<b>PART NO.</b>	<b>DESCRIPTION</b>
1	A125162-01	CENTER BALANCE CARTRIDGE
2	A125162-02	SEQUENCE CARTRIDGE

# HYDRAULIC VALVE IDENTIFICATION

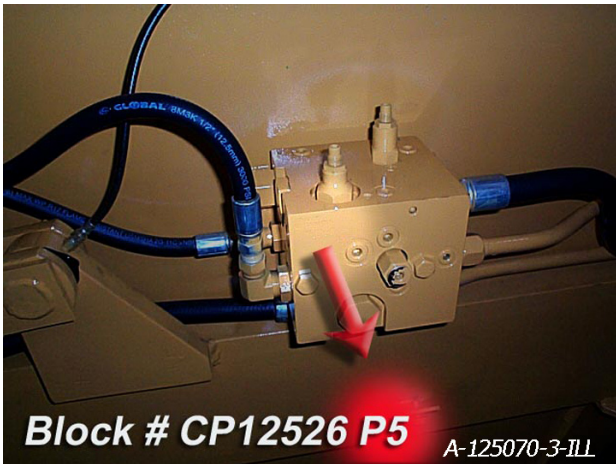

**New Valve**



**Old Valve**

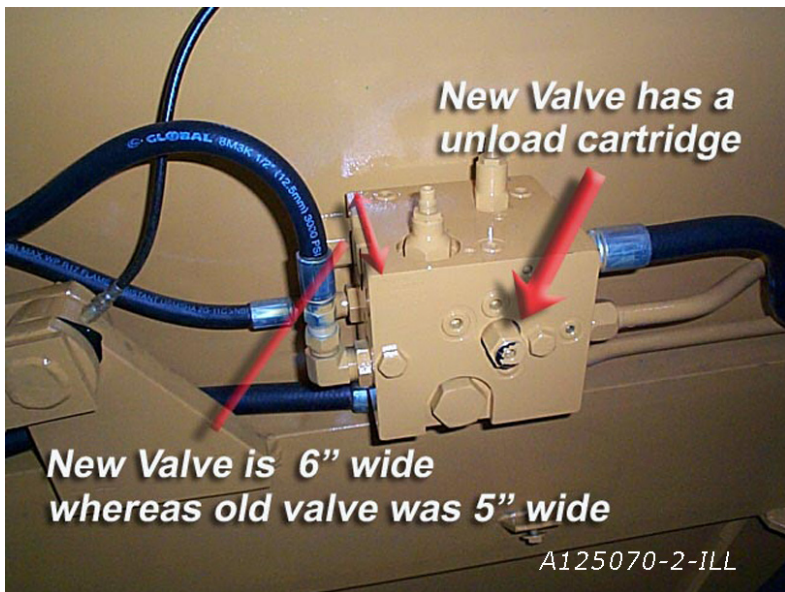

Visually there are several things you can check to ensure you have the correct valve. The new valve (shown on the left) is 6" wide whereas the older valve (shown below) was 5" wide. The new valve utilizes a unload cartridge that sticks outward on the side of the valve.



**IMPORTANT:** This Hyd. Manifold was intergrated into production Nov. 2003 It replaces A125055 valve which was used on S.N. 20750 to 20853. To confirm which valve you have, confirm with earlier valve I.D. page

**HYDRAULIC MANIFOLD ASSEMBLY  
A125070  
S.N. 20853 & above**

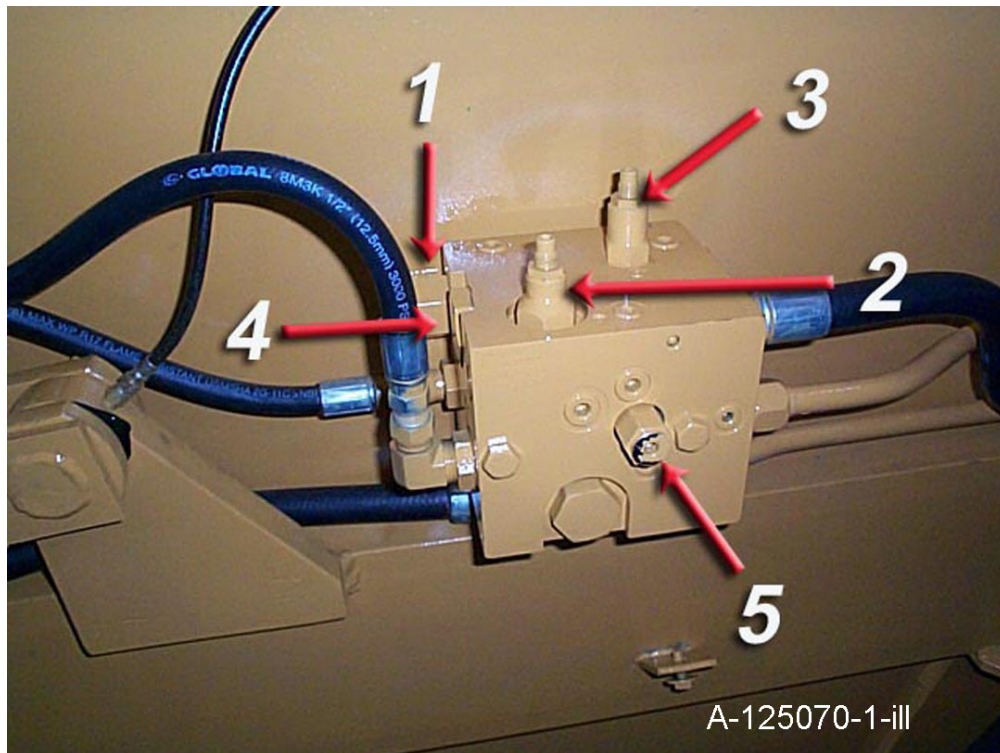

<u>ITEM #</u>	<u>PART NO.</u>	<u>DESCRIPTION</u>
1	A125070-01	DIRECTIONAL CONTROL VALVE
2	A125070-02	APRON SEQUENCE CARTRIDGE
3	A125070-03	PUSHOFF SEQUENCE CARTRIDGE
4	A125070-04	CHECK VALVE CARTRIDGE
5	A125070-05	UNLOAD CARTRIDGE

## SETTING THE APRON AND PUSHOFF VALVE

The manifold block containing the pushoff sequence valve cartridge and apron sequence valve cartridge is used to control two hydraulic circuits with one hydraulic remote. When the tractor hydraulic remote is activated, oil flows first to the apron cylinders until they are fully extended. Once the cylinders are fully extended, the apron circuits' hydraulic pressure begins to increase. Once the pressure threshold is surpassed (which is adjustable. See adjustment section), the sequence valve diverts the oil flow to the pushoff's hydraulic circuit. Once the push off is completely extended the operator then reverses the tractor's hydraulic remote. The counterbalance valve will hold the apron open until the push off is fully retracted. The Apron sequence valve then opens and allows the apron to close.

### Setting the valves:

#### STEP 1 PUSHOFF SEQUENCE VALVE

Loosen the lock nut (3/4") on the sequence valve cartridge. Turn the setscrew (1/4") clockwise until the front apron rises before the push-off begins to advance. (Earth-mover should be empty) Turn the adjustment screw an additional 1/4 turn clockwise and tighten jam nut.

#### STEP 2 APRON SEQUENCE VALVE

Loosen the lock nut (3/4") on the counterbalance valve cartridge. Turn the setscrew (4 mm) clockwise until the apron holds in a raised position while rear gate is being retracted. Turn adjustment screw an additional 1/4 turn, tighten jam nut. DO NOT tighten adjusting screw more than necessary.

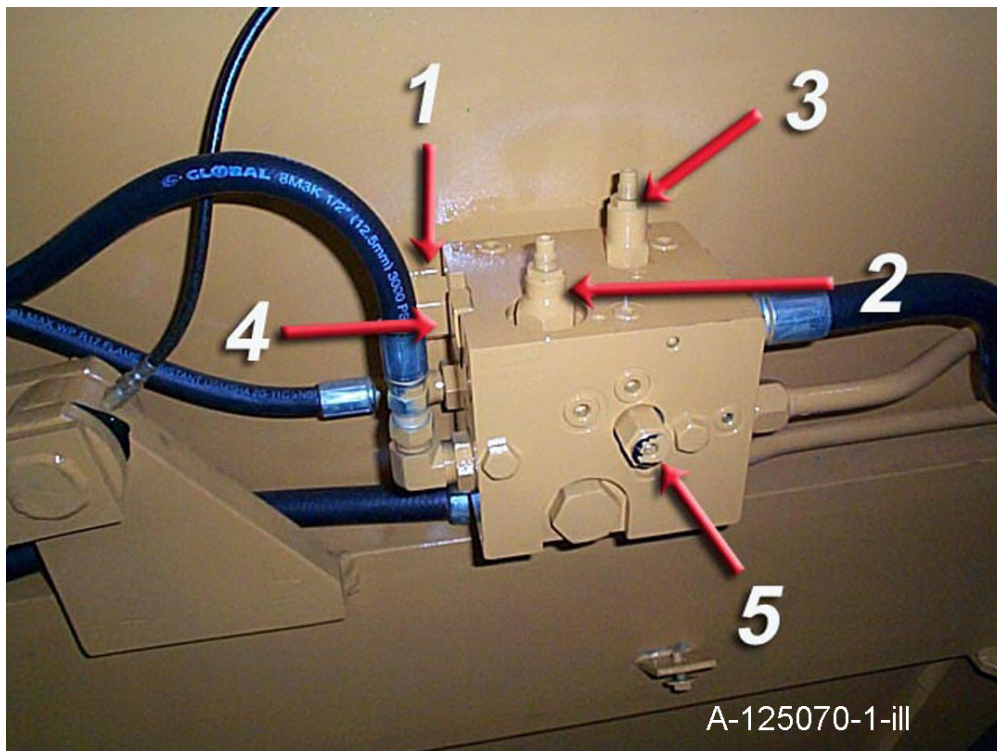

**IMPORTANT:** This Hyd. Manifold has been replaced by A125070 on Nov 2003. To confirm which valve you have, confirm with earlier valve I.D. page

**HYDRAULIC MANIFOLD ASSEMBLY  
A125055  
S.N. 20750 to 20853**

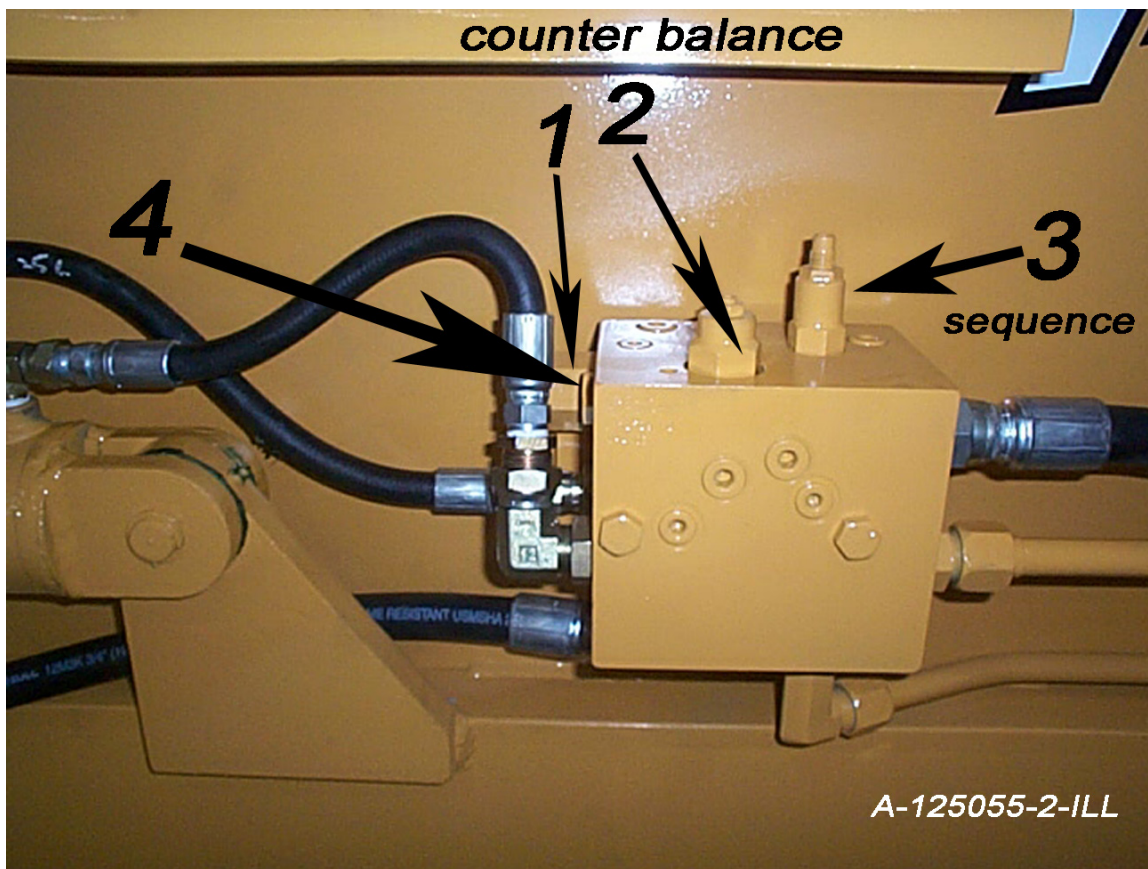

<b><u>ITEM #</u></b>	<b><u>PART NO.</u></b>	<b><u>DESCRIPTION</u></b>
1	A125055-01	DIRECTIONAL CONTROL VALVE
2	A125055-02	COUNTER BALANCE CARTRIDGE
3	A125055-03	SEQUENCE CARTRIDGE
4	A125055-04	CHECK VALVE
5	A125055	COMPLETE ASSEMBLY WITH ALL VALVES



# MAINTENANCE CHECKLIST

---

1. Grease all zerks.
  - a) Every 5 hours of operation.
  - b) See Lubrication Points section on next page.
  
2. Greasing the hubs.
  - a) Re-pack wheel bearings after 600 hrs of operation.
  - b) Completely clean grease out of hub and bearings every 1200 hours of operation.
  
3. Check tire pressure.
  - a) 29.5 – 25, 28-ply tire requires a tire pressure of 45-50 psi. If pressure drops, first secure valve stem, and if pressure continues to drop, contact Ashland Industries.
  
4. Check all pins for signs of wear.
  - a) Daily
  
5. Check wheel lug nut torque.
  - a) After first 2 hours of operation.
  - b) Recheck daily for next 2 weeks.
  - c) Tighten wheel lug nuts in a star pattern.
  - d) Torque wheel lug nuts to 750 ft-lbs.
  
6. Check and retighten all bolts.
  - a) After initial 10 hours of use.
  - b) Again after 50 hours of use.
  - c) See Torque Specifications on next page.
  
7. Inspect cutting edges.
  - a) Daily
  - b) Replace cutting edges when center blade has been worn to approximately 6" and side edges worn to approximately 4".

**CAUTION!** Failure to replace worn cutting edges may result in unnecessary wear to the earthmover sides and floor.

Note: Please specify left or right "L" shaped cutting edges when ordering replacements.

# TORQUE SPECIFICATIONS

---

<i>Grade 8</i>	
<i>Bolt</i>	<i>Torque</i>
<i>Diameter</i>	<i>ft-lbs</i>
1/4"	12
5/16"	25
3/8"	45
7/16"	70
1/2"	110
9/16"	150
5/8"	220
3/4"	380
7/8"	600
1"	900
1-1/8"	1280
Lug Nuts	750

## LUBRICATION

---

1. Grease all zerks every 8 hrs of operation with high quality, general-purpose grease.
  - a) Grease until grease flows from around pin.

### Lubrication Points

1. Hitch – Horizontal and vertical pins.
2. Lift Cylinders – Rod end; Both left & right sides.
3. Front Arm Pivot Joint – Both left & right sides.
4. Apron Pivot Pin; Both left & right sides.
5. Hold-down Rollers – Both left & right sides.
6. Tapered Rollers – Both left & right sides.
7. Lift Cylinders – Trunnion Mount Blocks; Both left & right sides
8. Lift Cylinders – Trunnion Mount Blocks; Both left & right sides

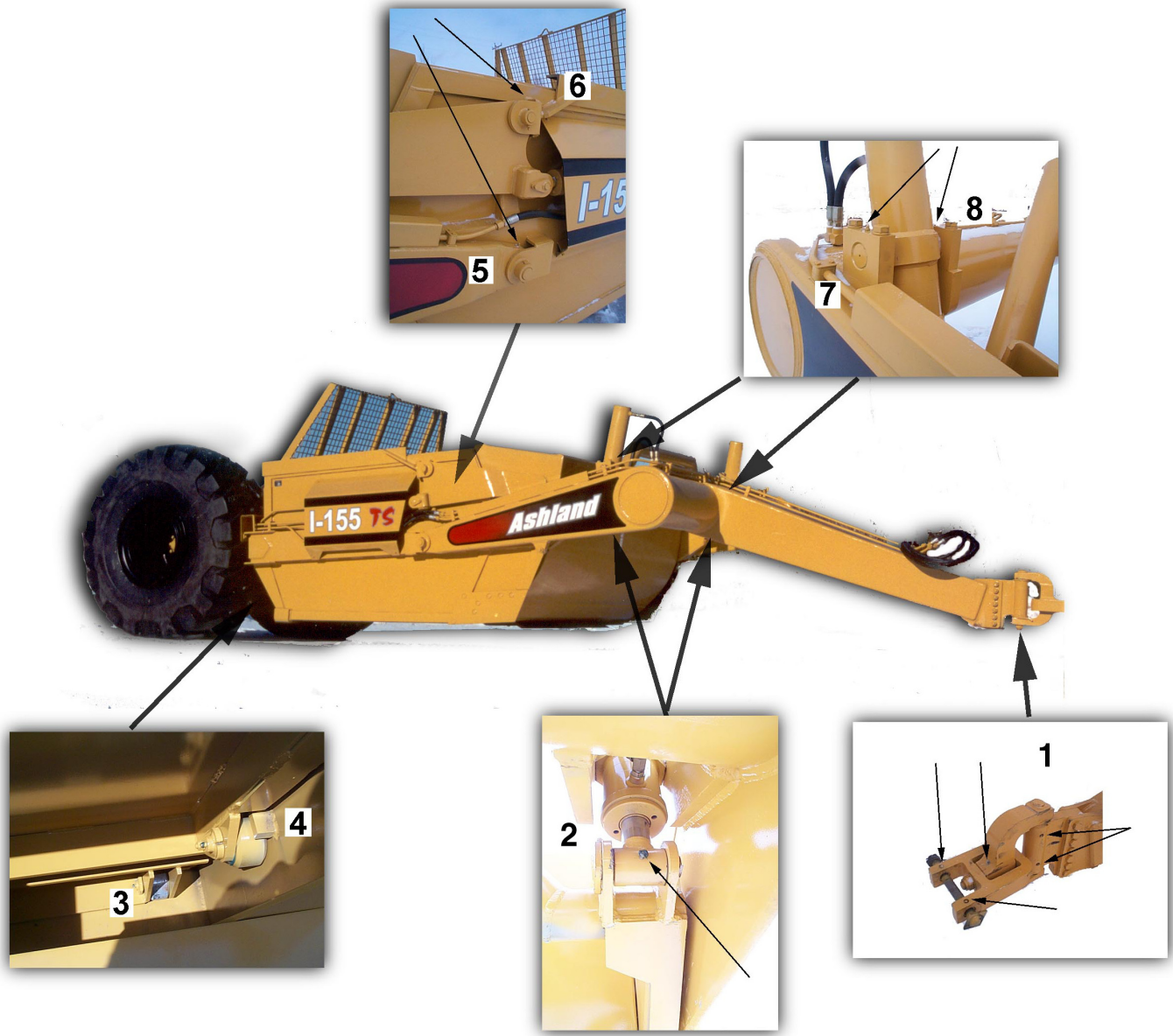

I-155ts-grease2-ILL

# HYDRAULIC SYSTEM

---

## **Standard Two-Circuit Hydraulic Plumbing**

The apron cylinders and the push-off cylinder are controlled on the same circuit with the sequence of the operation controlled by a sequence valve. The other hydraulic circuit controls the lift cylinders on the earthmover.

**\*To adjust the sequence valve, see Troubleshooting section.**

## **Optional Three-Circuit Hydraulic Plumbing**

The apron cylinders, push-off cylinder, and lift cylinders are all on separate hydraulic circuits.



**CAUTION!** Relieve all hydraulic pressure before working on the hydraulic system.

---

**WARNING!** High Pressure Fluid Hazard – To prevent serious injury or death from high pressure fluid:

- a) Relieve pressure on hydraulic system before repairing, adjusting, or disconnecting.
  - b) Wear proper hand and eye protection when searching for leaks.
  - c) Keep all components in good repair.
-

## PUSHING THE EARTHMOVER

---

The I-155TS was designed to be pushed when equipped with the optional push-bar. However, Ashland Industries, Inc. **STRONGLY** recommends using extreme caution when pushing the I-155TS earthmover to prevent any unnecessary damage.



**CAUTION!** The I-155TS earthmover must be pushed in a straight line with a maximum of a 150 hp dozer. Do not ram or jar the earthmover while pushing and push at a constant speed.

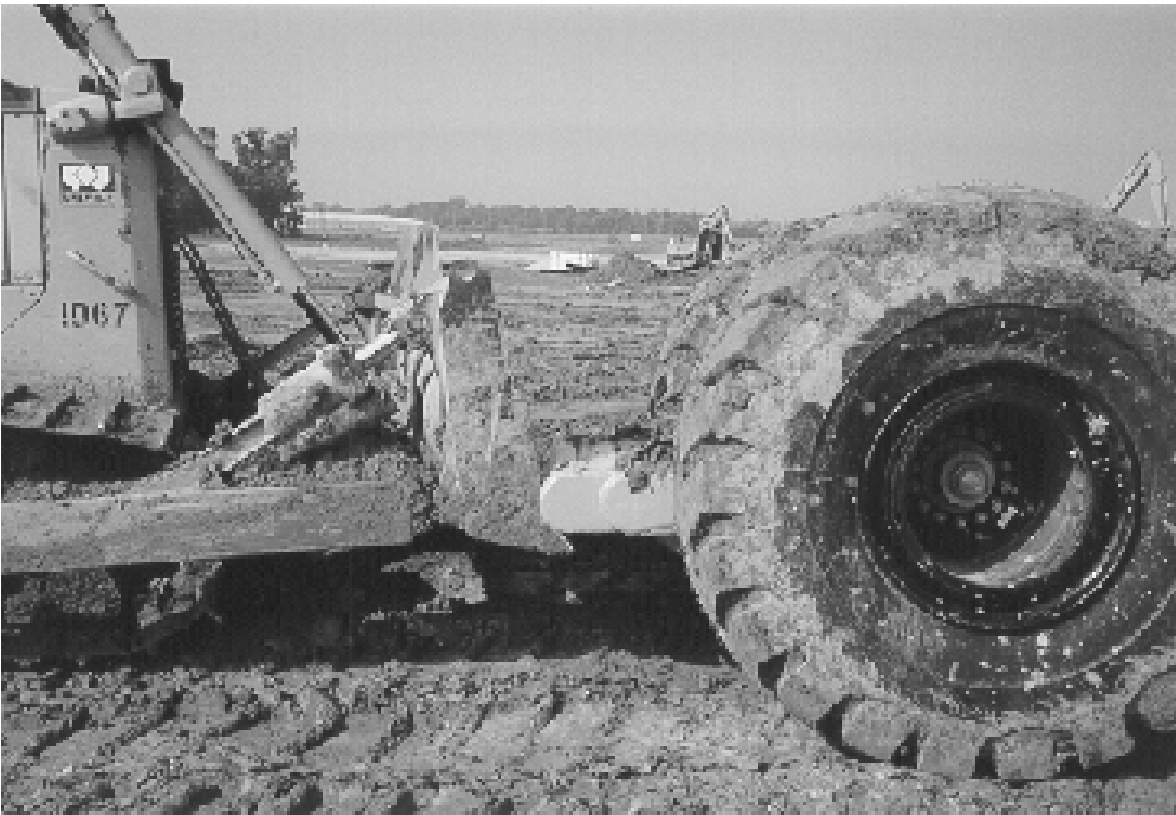

# TROUBLESHOOTING

---

## Introduction

---

With proper care and maintenance, the I-155TS will give many years of reliable service. When a situation arises where the earthmover performance is not satisfactory, this section will give some pointers on finding and correcting the problem.

---

### Grease zerk will not take grease.

---

1. Grease zerk plugged.
  - a) Remove and replace grease zerk.
2. Pin is frozen.
  - a) Remove, clean, and inspect pin.
  - b) Replace pin if necessary.
3. Bushing grease passage is not aligned with grease zerk.
  - a) Remove, clean, inspect, and realign bushing.
  - b) Replace bushing if necessary and realign.

---

### Cylinders will not hold in preset position, i.e. the cylinder creeps.

---

1. Seals leaking internally.
  - a) Remove and replace seal kit.

---

## Machine cuts unevenly.

---

1. Cutting edges worn unevenly.
  - a) Replace cutting edges.
2. Improperly inflated tires.
  - a) Check air pressure in tires.

---

## Apron closes slowly

or

## Apron and push-off are not working well together.

---

1. Sequence valve needs adjusting.
  - a) Remove acorn nut from end of sequence valve with a 1/2" wrench. Turn adjustment screw, using a 4mm hex wrench, clockwise until front apron rises before the push-off advances while the earthmover is empty. Turn the adjustment screw an additional 1/4 turn clockwise, then replace the acorn nut and tighten.
  - b) Torque check valve assembly and int. pilot plug to **25 ft-lbs maximum**.

**CAUTION!** Overtightening check valve assembly and int. pilot plug will cause internal damage to the sequence valve.



**Note: Check valve assembly may leak slightly when torqued to 25 ft-lbs.**

---

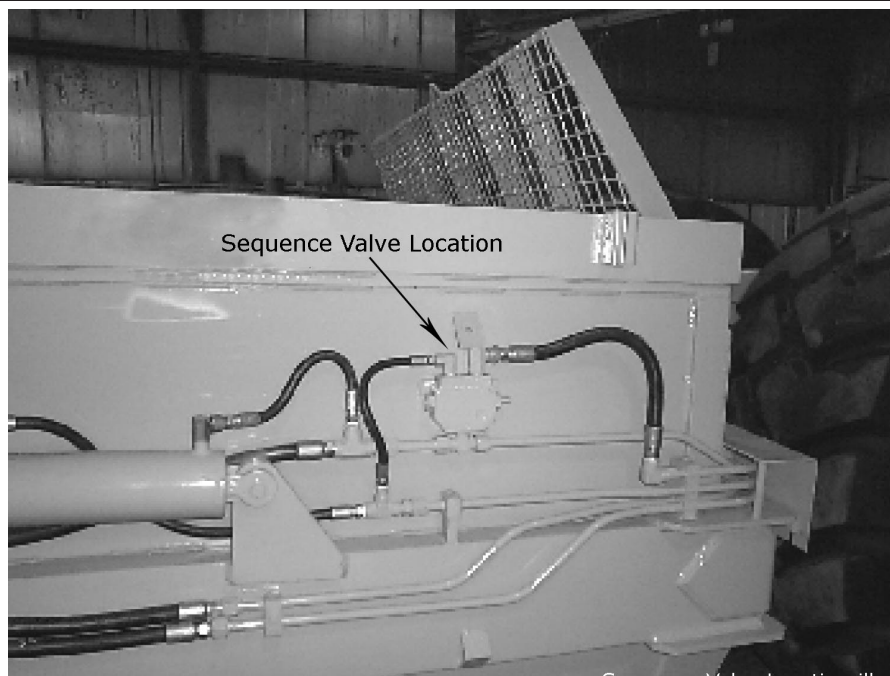

# Limited Warranty Statement

Ashland Industries Inc. warrants each new product to be free from defects in material and workmanship. This warranty is applicable only for the normal service life expectancy of the product or components, not to exceed **six consecutive months** from the date of delivery of the new Ashland Industries product to the purchaser, or the date the product is first put into service via a rental agreement or other means, whichever occurs first.

The major components of swivel hitches used on Industrial series scrapers are warranted for three consecutive months from the date of delivery of the new Ashland Industries product to the purchaser, or the date the product is first put into service via a rental agreement or other means, whichever occurs first, except those components described below.

Genuine Ashland Industries Inc. replacement parts and components will be warranted for 30 days from date of purchase, or the remainder of the original equipment warranty period, whichever is longer.

Under no circumstances will it cover any merchandise or components thereof, which in the opinion of the company, has been subjected to misuse, unauthorized modification, alterations, an accident or if repairs have been made with parts other than those obtained through Ashland Industries Inc.

Ashland Industries Inc. in no way warrants Tires since their respective manufacturer warrants these items separately. Please call Ashland Industries Inc. to receive phone numbers of tire suppliers.

Ashland Industries Inc. in no way warrants wearable items such as cutting edges, front dolly wheel balls, socket halves, rollers, bushings, yoke hitch pins, hitch bushings, etc..

Our obligation under this warranty shall be limited to repairing or replacing, free of charge to the original purchaser, any part that, in our judgement, shall show evidence of such defect, provided further that such part shall be returned within 30 days from the date of failure to Ashland Industries Inc. routed through the dealer and distributor from whom the purchase was made, transportation charges prepaid. Upon warranty approval proper credits will be reimbursed for transportation.

This warranty shall not be interpreted to render Ashland Industries Inc. liable for injury or damages of any kind or nature to person or property. This warranty does not extend to the loss revenue, extra labor cost associated with downtime, substitute machinery, rental or for any other reason.

Except as set forth above, Ashland Industries Inc. shall have no obligation or liability of any kind on account of any of its equipment and shall not be liable for special or consequential damages. Ashland Industries Inc. make no other warranty, expressed or implied, and, specifically, Ashland Industries Inc. disclaims any implied warrant or merchantability or fitness for a particular purpose. Some states or provinces do not permit limitations or exclusions of implied warranties or incidental or consequential damages, so the limitations or exclusion in this warranty may not apply.

This warranty is subject to any existing conditions of supply which may direct affect our ability to obtain materials or manufacture replacement parts.

Ashland Industries Inc. reserves the right to make improvements in design or changes in specifications at any time, without incurring any obligation to owners of units previously sold

No one is authorized to alter, Modify or enlarge this warranty nor the exclusion, limitations and reservations.

Ashland Industries Inc.  
Warranty Department