

# *Ashland* EARTHMOVERS

## I-180TS2 PARTS MANUAL

Version 6-06 SN: 21220 and Up



Ashland Industries Inc.  
1115 Rail Drive  
P.O. Box 717  
Ashland, WI. 54806  
877-634-4622 Toll Free - phone  
715-682-4622 phone  
715-682-9717 fax  
[www.ashlandind.com](http://www.ashlandind.com)

MEMBER  
**CIMA**  
CONSTRUCTION INDUSTRY  
MANUFACTURERS ASSOCIATION



# IMPORTANT

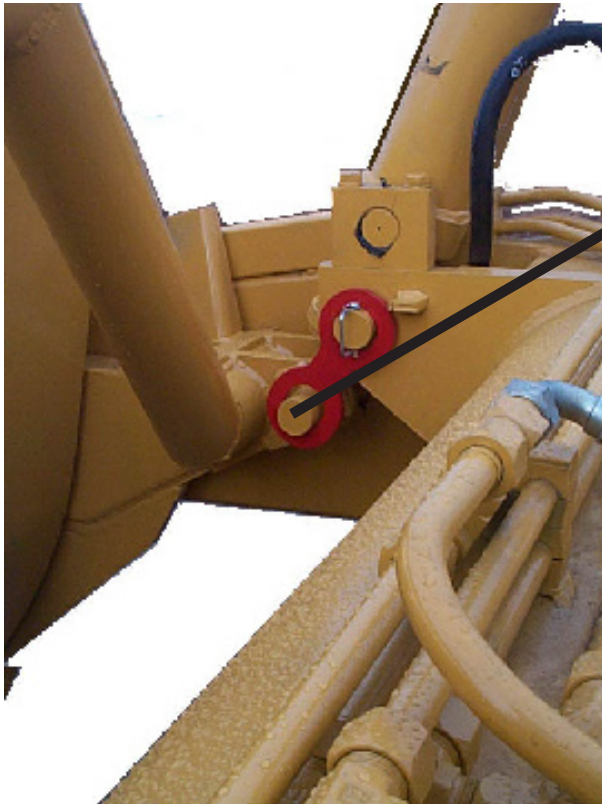

Please locate red Transport Links and remove prior to operation. Retract Lift Cylinder Circuit, Remove Safety Snap Pin, Remove link and replace into storage

position as shown in figure 2.

Reinstall Safety Snap Pins.

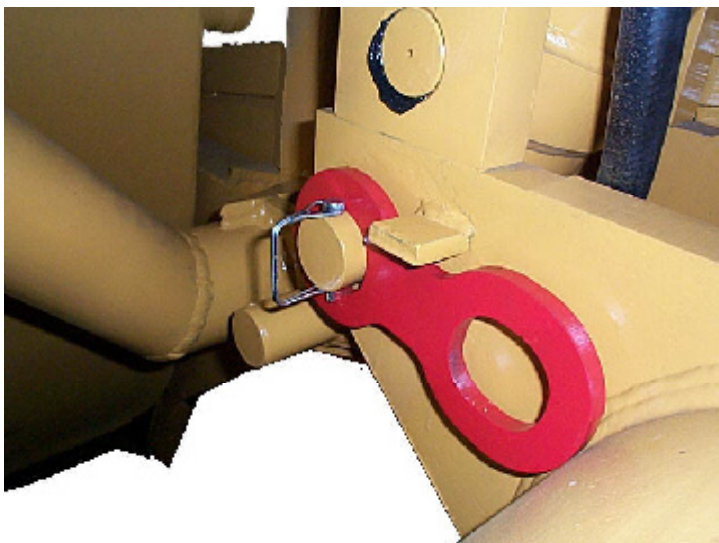

### *HOW TO ORDER PARTS:*

#### **IMPORTANT**

Parts must be ordered through your local authorized ASHLAND dealer.

Be sure to state MODEL and SERIAL NUMBER of your machine, PART NUMBER, DESCRIPTION and QUANTITY needed.

Unless this is done, we cannot provide prompt service or assure shipment of the correct parts.



Ashland Industries weldable replacement parts are available to rebuild, modify or update your scraper to current factory specifications.

### **INDEX**

Page 4.	Operators and Maintenance Instructions
Page 5.	Safety Guidelines
Page 6.	Illustration - Assembly
Page 7.	Complete Yoke Type Hitch
Page 8-9.	Swivel Hitch Assembly
Page 10.	Front Section Frame
Page 11.	Lift Cylinder 5-1/2 x 20
Page 13.	Apron Assembly
Page 12.	Apron Cylinder
Page 13-14	Bowl and Frame Assembly
Page 15.	Push Off Gate Assembly
Page 16.	Push Off Cylinder
Page 17.	Wheel Assembly
Page 18.	Front Section
Page 19-24	Hydraulic Plumbing
Page 25	Identification, Illustration, Parts List and Adjustment - Hydraulic Valve
Page 26.	Hydraulic Schmetc
Page 27-28	Grease Locations
Page 29-32	Service Manual Appendix
Page 33.	Warranty Statement

# **OPERATORS AND MAINTENANCE INSTRUCTIONS**

This scraper is a durable piece of equipment and with proper care will yield many years of trouble free operation. The scraper requires a power source with TWO 4 way (double acting) hydraulic control valves.

The scraper should be greased at all points where grease fittings are provided. Connect hydraulic hoses to the tractor and retract lift cylinders to **REMOVE TRANSPORT LOCK PINS** (point A), then extend and retract all cylinders several times to force out any air from the hydraulic cylinders and lines. Check the oil levels in the tractor hydraulic system and add to maintain the proper level. Care should be used when adding oil or when disconnecting any oil line to keep all dirt out of the oil as dirt is a major factor in the failure of hydraulic components.

When the scraper is placed into operation, the operator will have to "feel out" the amount of depth of cut to obtain maximum loading efficiency. This is usually accomplished by taking a lesser and more uniform cut; however, some soil conditions such as loose sand may require a "pumping action" obtained by taking successive deep cuts and lifting out of cut as the tractor begins to lose power or traction.

1. After 10 hours work, all bolts should be checked and tightened if necessary.
2. Every 10 hours all grease fittings should be lubricated.
3. After 50 hours work, all bolts should be rechecked and tightened if necessary. Check wheel bearings and adjust if necessary.
4. After 300 hours work, clean and repack wheel bearings and replace, if necessary, cutting edges, worn pins, etc.
5. Maintain tire pressure at 45 to 50 psi.



## SAFETY SIGNAL WORDS

Note the use of the signal words DANGER, WARNING and CAUTION with the safety messages. The appropriate signal word for each has been selected using the following guidelines:

**DANGER:** Indicates an imminently hazardous situation that, if not avoided, will result in death or serious injury. This signal word is to be limited to the most extreme situations typically for machine components which, for functional purposes, cannot be guarded.



**WARNING:** Indicates a potentially hazardous situation that, if not avoided, could result in death or serious injury, and includes hazards that are exposed when guards are removed. It may also be used to alert against unsafe practices.



**CAUTION:** Indicates a potentially hazardous situation that, if not avoided, may result in minor or moderate injury. It may also be used to alert against unsafe practices.



## GENERAL SAFETY GUIDELINES

Safety of the operator is one of the main concerns in designing and developing a new piece of equipment. Designers and manufacturers build in as many safety features as possible. However, every year many accidents occur which could have been avoided by a few seconds of thought and a more careful approach to handling equipment. You, the operator, can avoid many accidents by observing the following precautions in this section. To avoid personal injury, study the following precautions and insist those working with you, or for you, follow them.

Replace any CAUTION, WARNING, DANGER or instruction safety decal that is not readable or is missing. Location of such decals is indicated in this booklet.

Do not attempt to operate this equipment under the influence of drugs or alcohol.

Review the safety instructions with all users annually.

This equipment is dangerous to children and persons unfamiliar with its operation. The operator should be a responsible adult familiar with farm machinery and trained in this equipment's operations. **Do not allow persons to operate or assemble this unit until they have read this manual and have developed a thorough understanding of the safety precautions and of how it works.**

To prevent injury or death, use a tractor equipped with a Roll Over Protective System (ROPS). Do not paint over, remove or deface any safety signs or warning decals on your equipment. Observe all safety signs and practice the instructions on them.

Never exceed the limits of a piece of machinery. If its ability to do a job, or to do so safely, is in question - **DON'T TRY IT.**

ASHLAND I-180TS

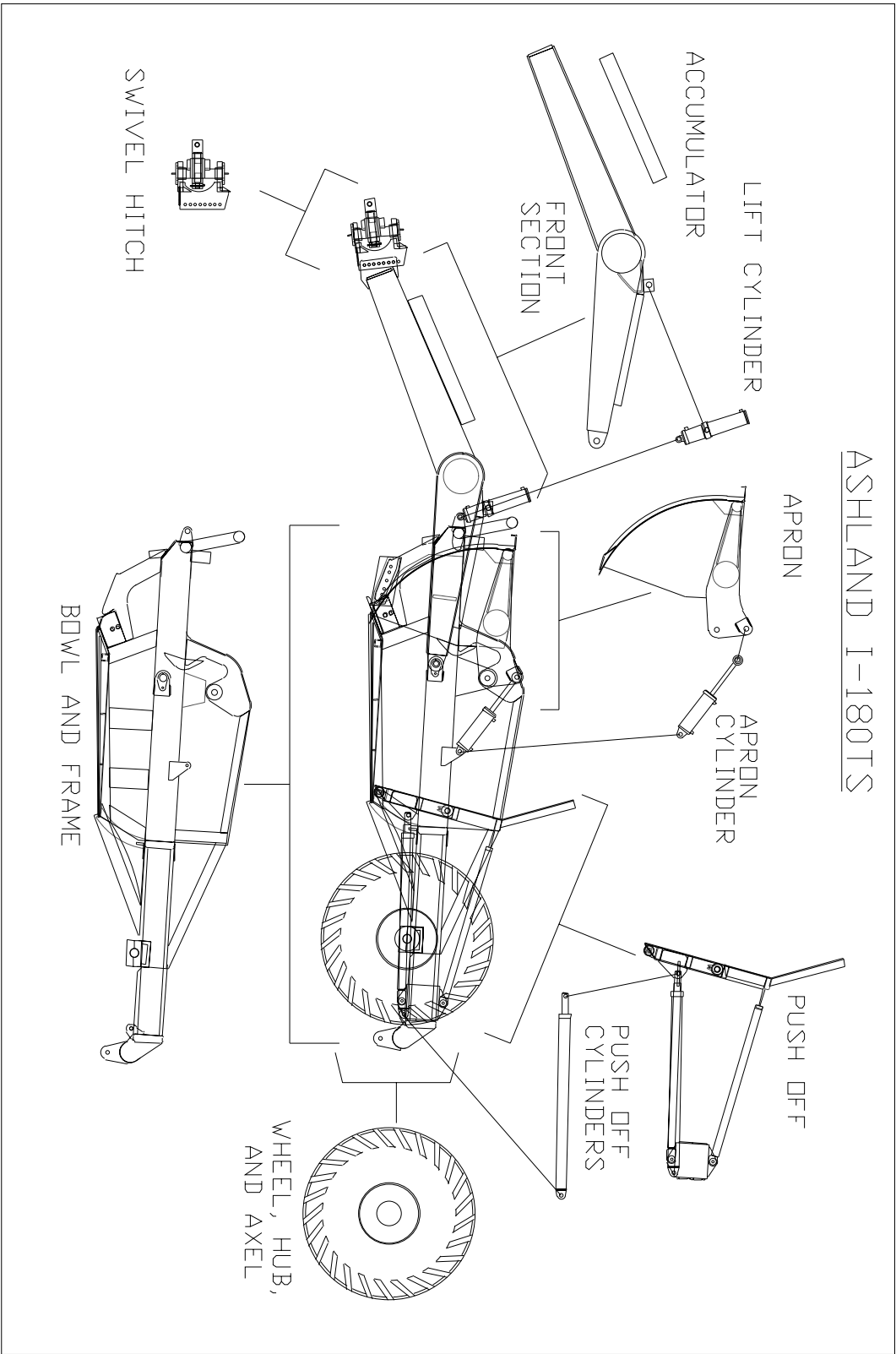

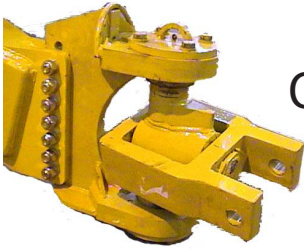

# A125056

## Complete Yoke Type Hitch

Implemented April 2003

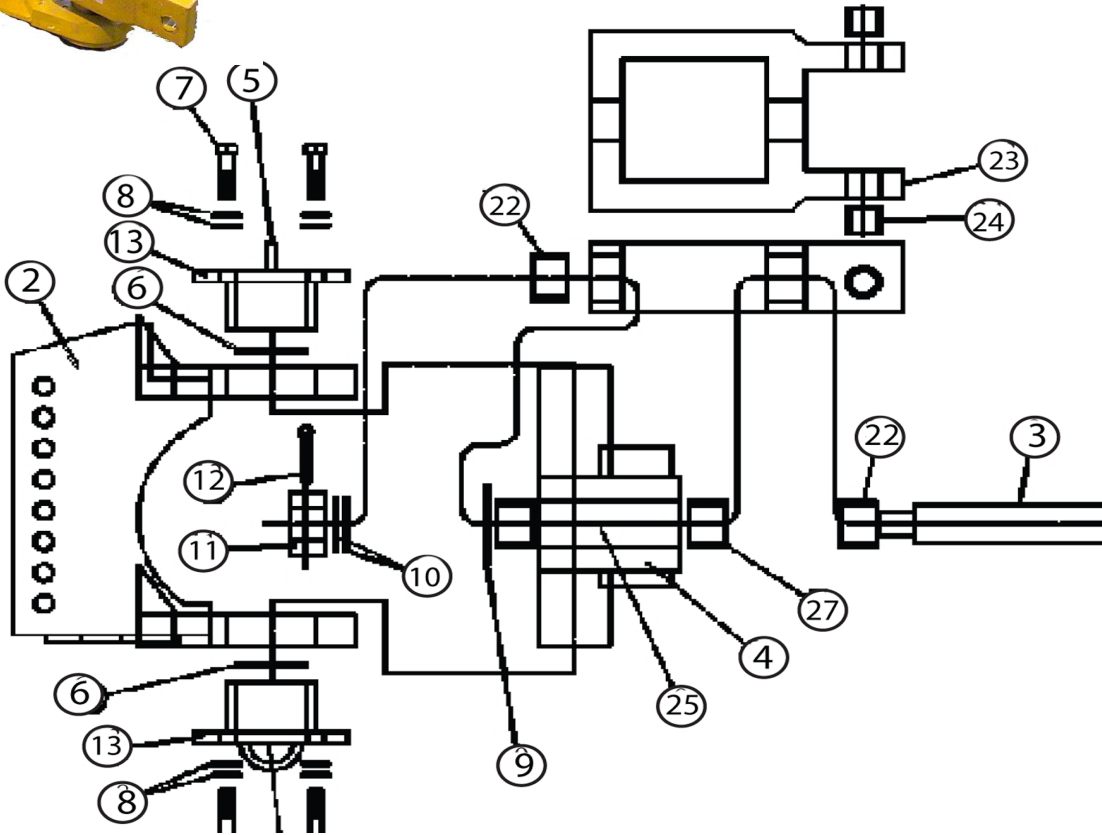

<b>KEY NO.</b>	<b>PART NO.</b>	<b>DESCRIPTION</b>
2.	A125056-02	UTIL HITCH BRKT
3.	A125056-03	MDU HITCH PIN
4.	A125056-04	MDU HITCH SWIVEL
5.	A125056-05	19C 18D HITCH CAP
6.	A125056-06	19C 18D WASHER SWIVEL HITCH
7.	A125056-07	BOLT: 3/4 X 3 HEX GR 8
8.	A125056-08	WASHER: FLAT - 3/4 HARD F-436
9.	A125056-09	WASHER: FKAT-2-1/2 HARD F-436
10.	A125056-10	WASHER: FLAT-1-1/2 HARD F-436
11.	A125056-11	NUT: SLOTTED 1-1/2 COARSE
12.	A125056-12	PIN: COTTER 5/16 X 2-1/2
13.	A125056-13	19C 18D SWIVEL HITCH CAP SEAL
22.	A125056-22	BUSHING: 275250187
23.	A125056-23	REYNOLDS UTILITY HITCH YOKE
24.	A125056-24	BUSHING: 175150150
25.	A125056-25	ZERK - STRAIGHT
26.	A125056-26	ZERK - 90 DEGREE
27.	A125056-27	BUSHING: 300251200

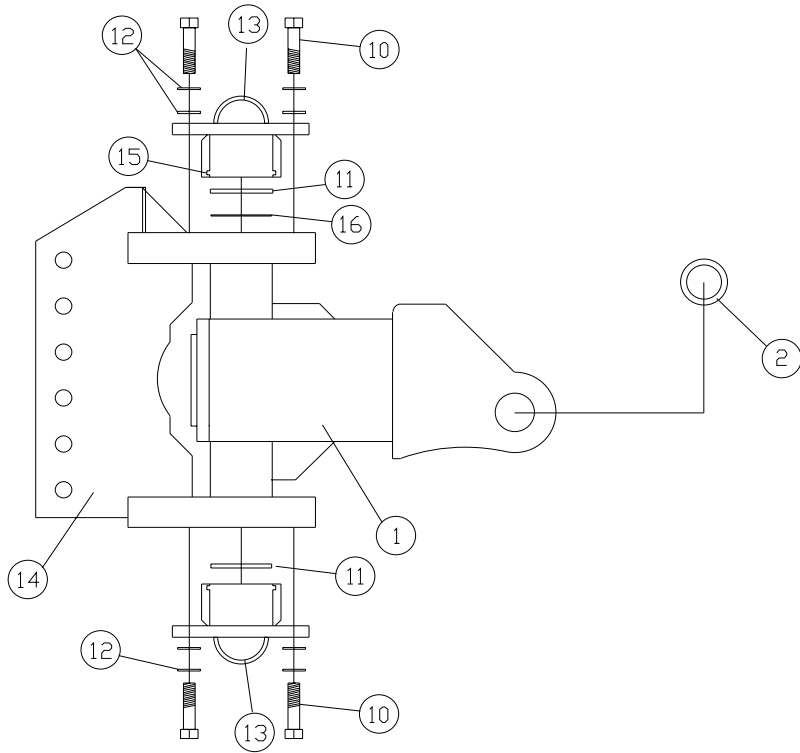

## SUPER CAPACITY SWIVEL HITCH ASSEMBLY A125057

### COMPLETE HITCH: H.D. ICON 360 DEG. SWIVEL

<b>ITEM</b>	<b>QTY</b>	<b>PART NUMBER</b>	<b>DESCRIPTION</b>
1	1	A125057-01	Swivel Hitch Yoke
2	2	A125057-02A	Bushing, 1-1/2" ID, Reynolds Spec.
		A125057-02JD	Bushing, 60 mm ID, John Deere Spec.
10	8	AFB-00064	HHCS: 3/4 NC X 3" GR. 8 ZINC
11	2	A125056-06	WASHER: FOR ICON HITCH CAP
12	16	AFW-00007	WASHER: FLAT 3/4" ZINC USS
13	2	A125057-13	HITCH CAP, ICON
14	1	A125057-14	SWIVEL HITCH BRACKET, 7 HOLE
15	2	A125057-15	SEAL, HITCH CAP
16	1	A125057-16	SHIM, HITCH CAP



## I-180TS Front Section Frame A123320

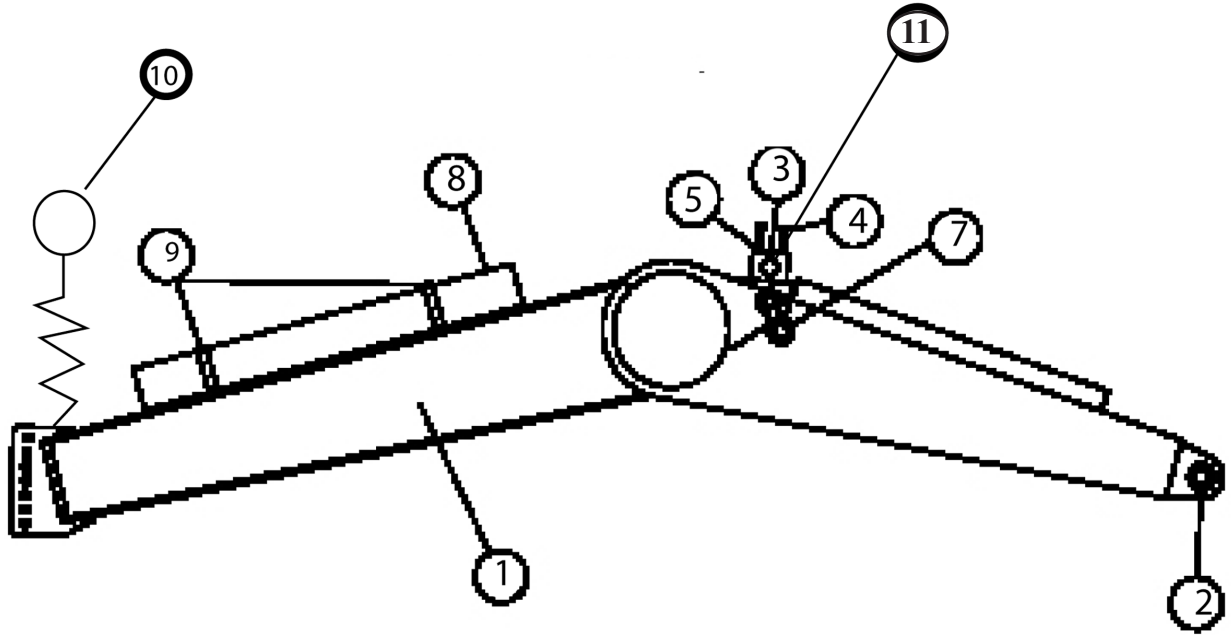

<b>ITEM</b>	<b>QTY</b>	<b>PART NUMBER</b>	<b>DESCRIPTION</b>
1	1	A123320	Front Section
2	2	A123320-8	2" ID x 3-1/2" OD x 3" long bronze bushing
3	4	A123293A	Trunion mount block
4	8	AFB-00039	Bolt, 3/4" NC x 5-1/2" long, gr. 8
5	8	AFW-00002	3/4" lock washer
7	2	A123320-20	Travel Lock
8	1	A125005	Accumulator
9	2	A125009	Mounting brackets
10	1	A125109A	Hose Support
11	2	A125179	Trunion Bushing

**MODEL I-180  
LIFT CYLINDER 5 1/2 X 20  
PART NO. A125044**

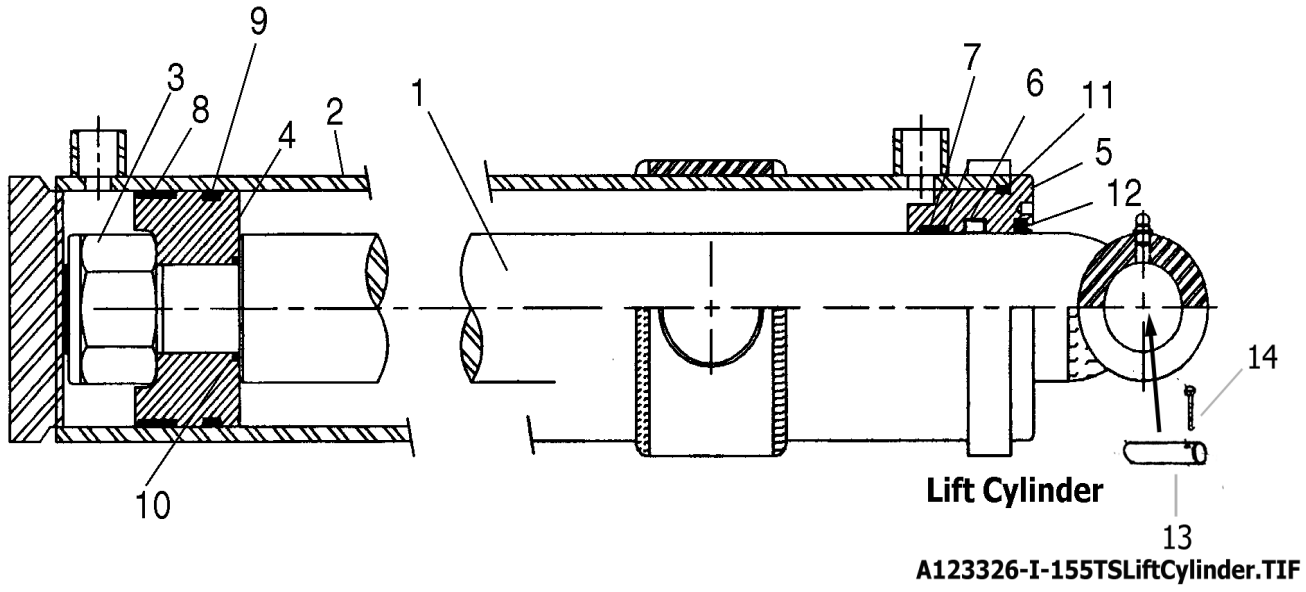

A123326-I-155TSLiftCylinder.TIF

<b>KEY NO.</b>	<b>PART NO.</b>	<b>DESCRIPTION</b>
1.	A123326-1	Piston Rod: 2-1/2"
2.	A125044-02	Barrel Weldment, 5-1/2"
3.	AFN-00018	Nut: Lock 1-1/2-12
4.	A125044-04	Piston, 5-1/2"
5.	A125044-05	Gland, 5-1/2"
6.	A123324-6	Rod Seal
7.	A123324-5	Wear Band ID for Gland
8.	A125044-10	Wear Ring, 5-1/2"
9.	A125044-15	Piston Seal, 5-1/2"
10.	A123324-10	O-Ring, ID of Piston
11.	A125044-20	O-Ring, OD of Gland
12.	A123324-7	Rod Wiper
	A125044-40	Seal Kit (Items 6-12)
13.	A123335	Pin, 2" x 10-1/2" lg.
14.	AFP-00001	Cotter Pin, 1-4" x 3"

## A123322 Apron Model I-180-TS2

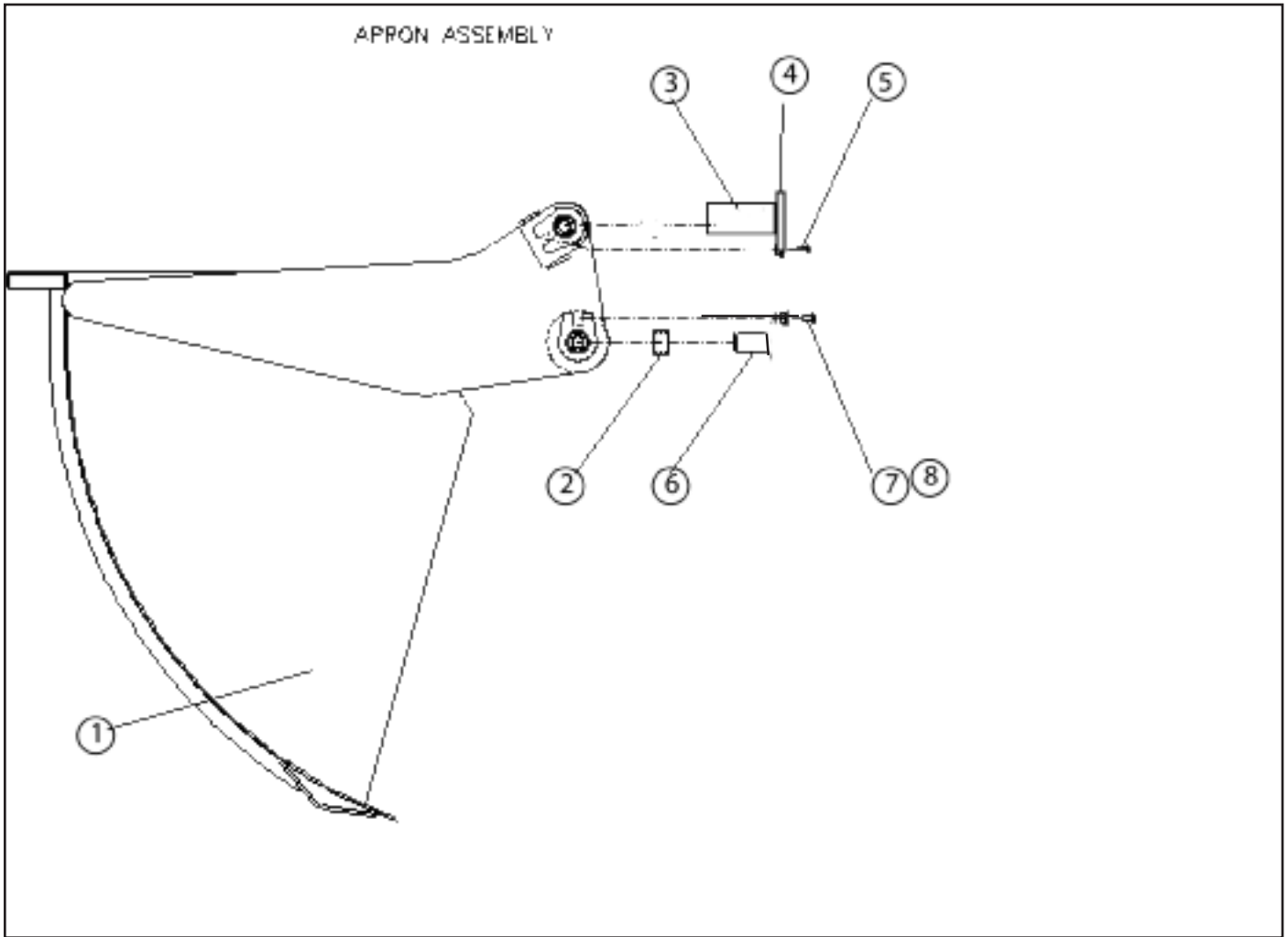

<b>ITEM</b>	<b>QTY</b>	<b>PART NUMBER</b>	<b>DESCRIPTION</b>
1	1	A123322	Apron Model I-180-TS
2	2	A123299-10	Bushing, 2- 2/8" O.D. x 2" I.D. x 1-1/2" long with grease groove
3	2	A123322-14	Pin: 2" x 3-3/4" long, For Apron cyl rod end
4	2	A123358	Flanged bolt Bushing
5	4	AFB-00079	Bolt: 5/8" x 1-1/2"
6	2	A123321-1 	Apron Pivot Pin w/grease zerk
7	2	AFB-00012	1/2" Bolt
8	2	750500	1/2" lock

**APRON CYLINDER I-180TS2  
PART NO. A125065  
NEW STYLE**

**IMPORTANT:** This is the new style Apron Cylinder. The old style has reinforcement strap on the outside of the barrel near the rod end, the new style does not. New style was integrated into production Sept. 2003, sn 20808 and above.

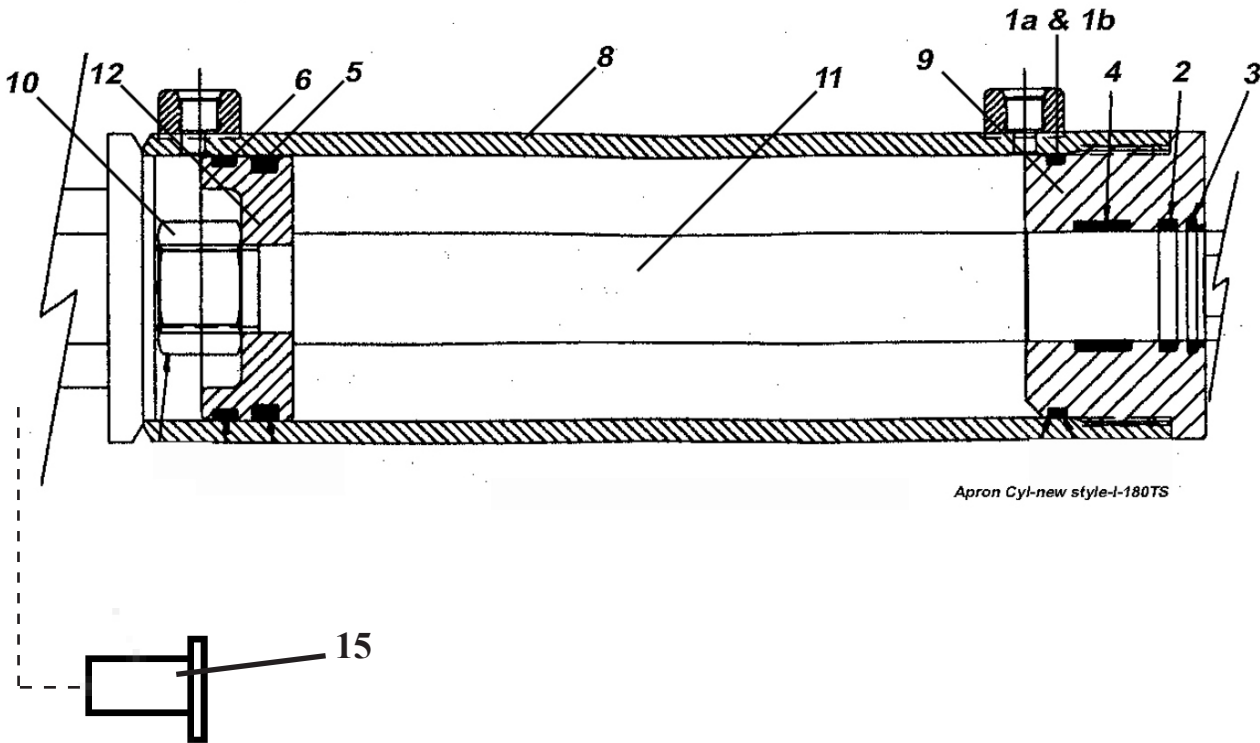

ITEM	QTY	PART NUMBER	DESCRIPTION
1a	1	A125065-1a	O-RING (-248)
1b	1	A125065-1b	B/U RING 5" OD X 1-8" C.S. (-248)
2	1	A125065-2	ROD SEAL U-CUP
3	1	AHS-00096	WIPER SEAL
4	1	A125065-4	WEAR RING
5	1	A123324-9	PISTON SEAL = PSP TYPE
6	1	A125065-6	WEAR RING
8	1	A125065-01	BARREL
9	1	A125065-02	HEAD
10	1	AFN-00018	LOCK NUT
11	1	A125065-04	ROD
12	1	A125065-03	PISTON
13	1	A125065-05	SEAL KIT, INCLUDES ITEMS 1 - 7
15	2	A123322-09	Pin: Apron cylinder barrel end

# I-180 BOWL AND FRAME ASSEMBLY

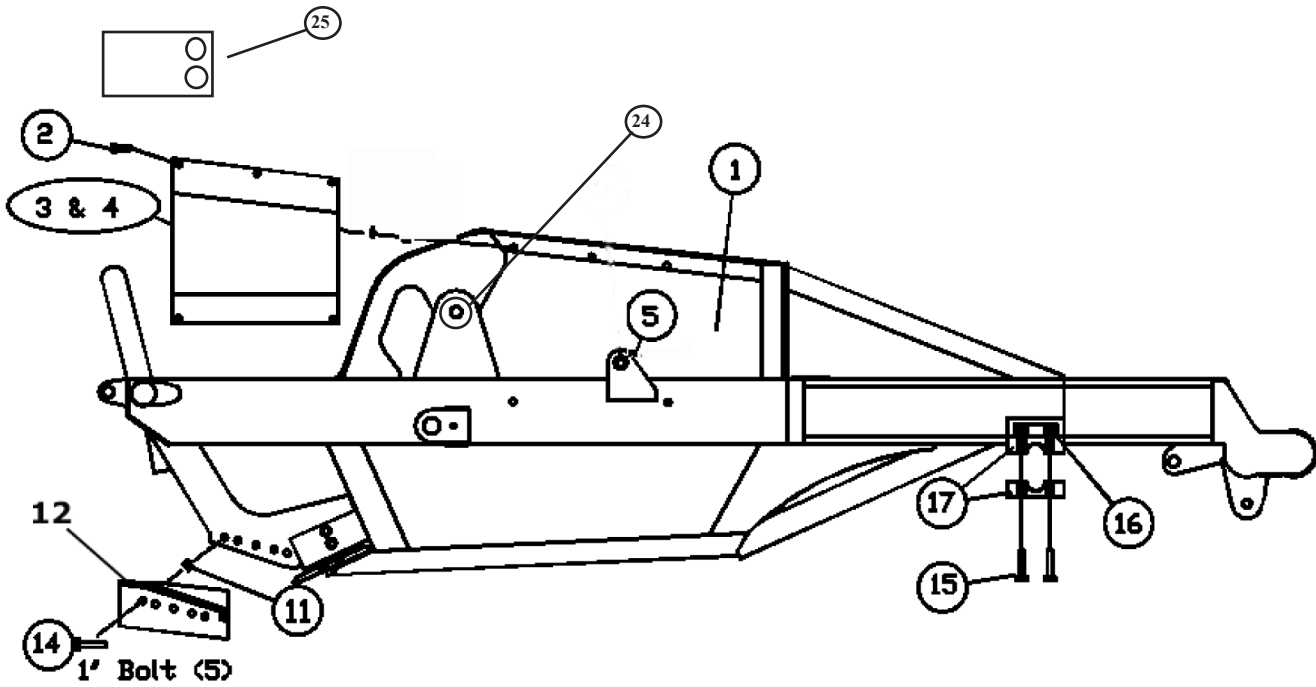

# BOWL AND FRAME ASSEMBLY

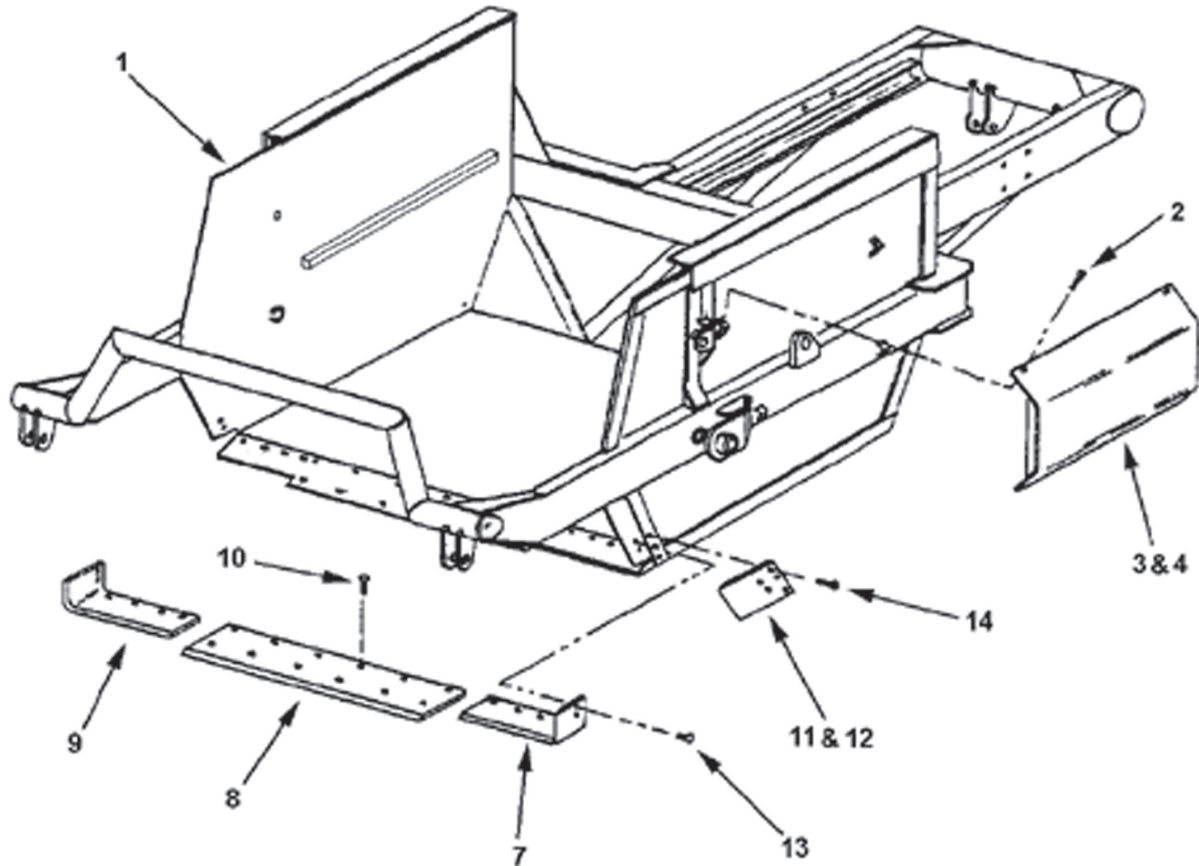

110-130 bowl

## I-180 BOWL AND FRAME PARTS LIST

<u>ITEM</u>	<u>QTY</u>	<u>PART NUMBER</u>	<u>DESCRIPTION</u>
1	1	A123321	Bowl and frame assembly
2	10	AFB-00094	Flanged Bolt: 3/8" NC x 1" long
3	1	A123369-1L	Left side dirt shield
4	1	A123369-1R	Right side dirt shield
5	2	A125018	Bushing: 2-3/8" OD x 2" ID x 1-1/4 Lg.
7	2	A123355	Corner cutting blade, "L" shape, reversible, 13" x 36-1/2" L & R
Each blade requires: (6) 1" x 2-3/4" plow bolts, (2) 1" x 2-1/2" plow bolts, (8) 1" NC nuts			
	2	A125103	Left & Right Straight Corner Blade w/6 1 x 2-3/4 plow bolts & nuts each, 6 per side
8	1	A123356SER (stardard)	Center blade, Serrated Both sides, Reversible
	1	A123356SER1	Center blade, 1-side Serrated & 1-side Straight
	1	A123356	Center cutting blade, reversible, Straight, Blade Dimensions. 16" x 54-1/4"
	1	A125072*	Center blade, 18" Straight, reversible
	1	A125072-SER*	Center blade, 18" dbl serrated, reversible
	1	A125072-SERTC*	Center blade, 18" dbl serrated w/ 2-pass Tungsten/Carbide imbedding - reversible. Blade Dimensions. 18" x 54-1/4"
Blade requires: (9) 1" x 2-3/4" plow bolts, (9) 1" NC nuts			
10	21	PB1P-NC-100-0275	Plow bolt: 1" NC x 2-3/4" long
11	25	AFN-00012	Nut: 1" NC
12	2	A123357	Bank shaver/router bit, reversible, L & R
Each blade requires: (5) 1" NC x 3" long bolts, (5) 1" NC nuts			
13	4	PB1P-NC-100-250	Plow bolt: 1" NC x 2-1/2" long
14	10	AFB-0018	Bolt: 1" NC x 3" long (5 per router blade)
15	4	AFB-00067	Bolt: 1-1/4" NF x 7-1/2" long
16	4	AFN-00032	Nut: 1-1/4" NF
17	2	A123321-65	Axle mount
18	2	A123335	Lift cylinder pin
19	2	A123321-09	Main frame pin
20	2	A123358	Flanged bolt bushing
21	2	AFB-00079	Bolt: 5/8" x 1 1/2" long
22	2	A123321-98	Pins
23	1	A123321-89	Pin Keeper
24	2	A123321-107	Weld in Apron Boss
25	2	A123369-13	Dirt Shield Flap

\* Optional Center Blades

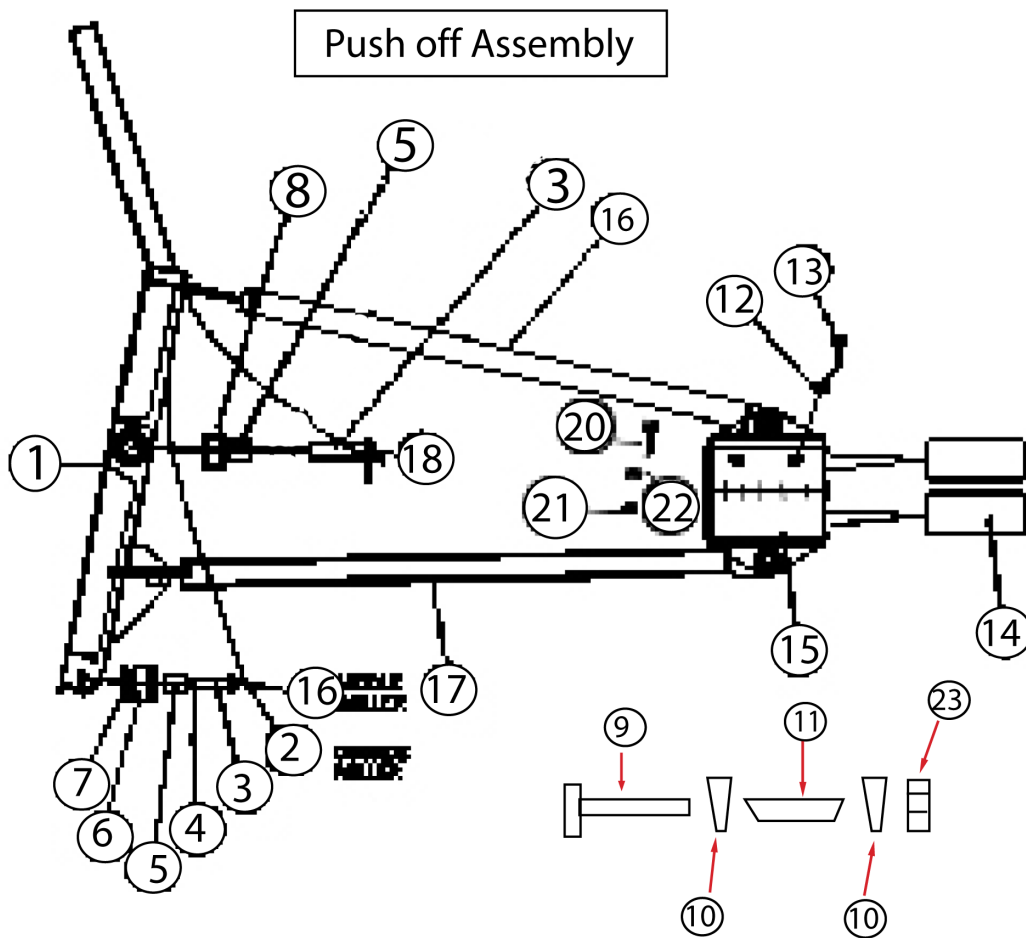

ITEM	QTY	PART NUMBER	DESCRIPTION
1	1	A123323	Push Gate Assembly
2	2	A125023	Grease line, outside floor roller 48"
3	4	A123323-21	Pin: 1-1/4" x 4-1/8" long
4	3	AFP-0001	Cotter Pin: 1/4" x 3 1/2"
5	4	A10163	Bushing: 1-3/4" O.D. x 1-1/4" I.D.
6	3	A10164	Roller
7	6	AFW-00015	Washer
8	2	A123459	V-Roller
9	1	AFB-00103	1 x 12 Bolt
10	2	AFW-00019	Wedge Washer
11	1	A123323-48	Wedge Spacer
12	12	AFN-00023	JamNut: 3/4" NF
13	12	AFB-00060	Bolt: 3/4" NF x 2" long
14	4	A123364-08	Plastic slide
15	1	A123364	Slide Guide Box
16	2	A123323-36	Top Support
17	2	A123323-35	Bottom Support
18	2	A125022	Grease line, hold down roller 18"
19	1	A125023	Grease line, middle floor roller 96"
20	8	6684	5/8 x 2 NC gr. 8 Bolts
21	8	7530	5/8 NC gr. 8 Nuts
22	8	8110	5/8 Lock Washer
23	1	AFN-00001	NF Nut

**I-180 TS2 Push Off Cylinder**  
**Part # A123360**  
**2 required**  
**4" Bore x 60" Stroke**

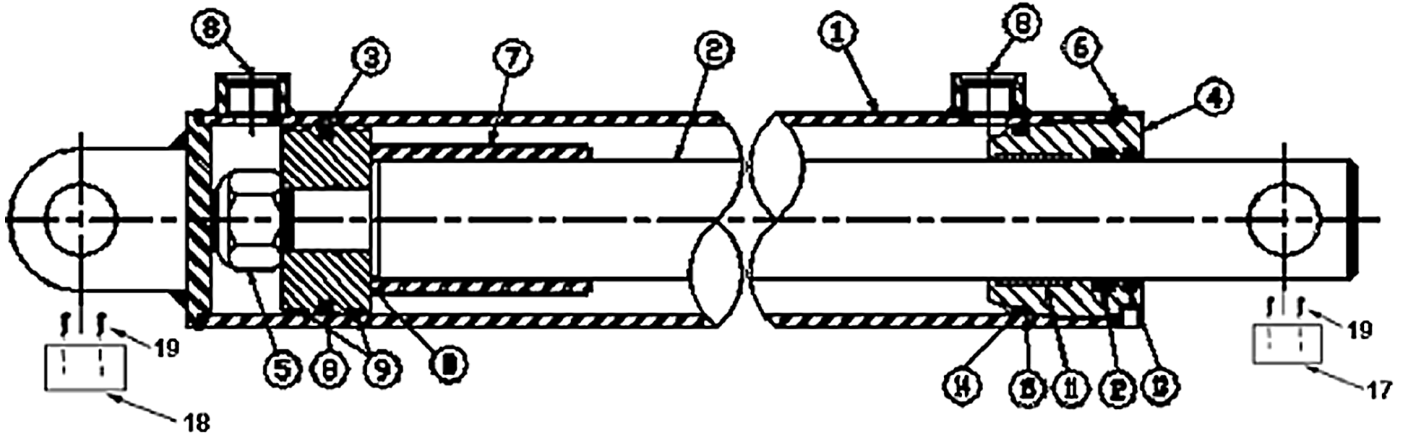

<b>ITEM</b>	<b>QTY</b>	<b>PART NUMBER</b>	<b>DESCRIPTION</b>
1	1	A123360-01	BARREL
2	1	A123360-02	ROD
3	1	A123360-03	PISTON
4	1	A123360-04	GLAND
5	1	A123360-05	LOCK NUT
6	1	A123360-06	SCREW
7	1	A123360-07	SPACER SLEEVE
8	1	A123360-08	PISTON SEAL
9	1	A123360-09	WEAR RING
10	1	A123360-10	O-RING
11	1	A123360-11	WEAR RING
12	1	A123360-12	ROD SEAL
13	1	A123360-13	WIPER
14	1	A123360-14	O-RING
15	1	A123360-15	BACK-UP RING
16	1	A123360-16	SEAL KIT, INCLUDES ITEMS 8 - 15
17	2	A123323-38	Rod End Pin 5-1/16 x 1-1/2
18	2	A123323-41	Barrel End Pin 4-9/16 x 1-1/2
19	8	AFP-00001	1/4 x 3 Cotter Pin



# WHEEL ASSEMBLY

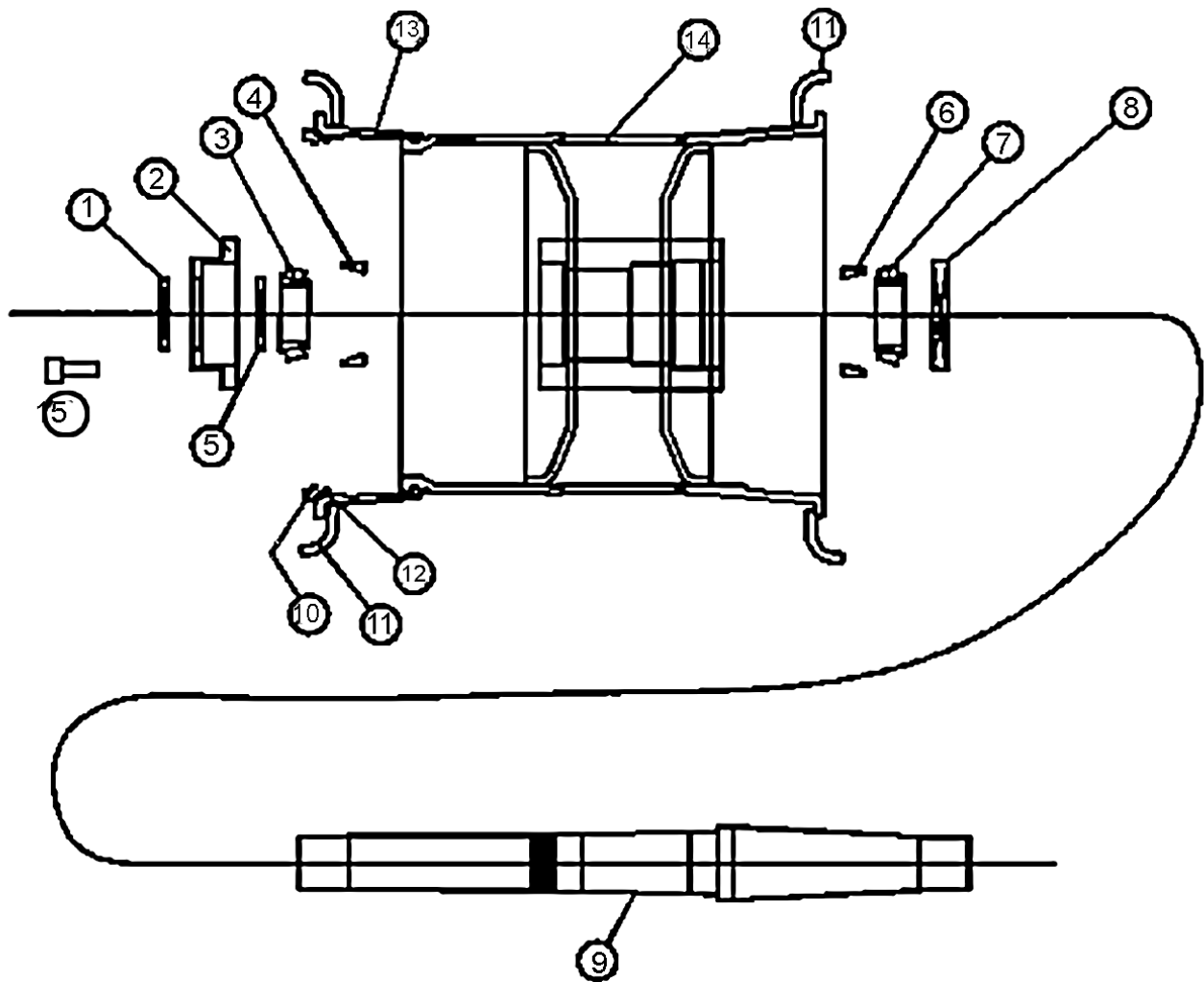

ITEM	QTY	PART NUMBER	DESCRIPTION
1	1	A125008	Outer Seal CRWH1
2	1	A123359-03	Cap- seal mount
3	1	A125016	Outer Bearing Cone 77375
4	1	A125017	Outer Bearing Cup 77675
5	1	A125013	Spindle nut
6	1	A125015	Inner Bearing Cup
7	1	A125014	Inner Bearing Cone
8	1	A125007	Inner Seal CRSHA1
9	1	A123368	Axle
10	1	A12042	Lock Ring
11	2	A12041	Side Ring
12	1	A12047	O-Ring
13	1	A12043	Collar
14	1	A123359-04	25 x 25 wheel/hub
15	4	AFB-00082	5/16 x 1-1/2 Bolt for Hubcap

# Front Section I-180TS2

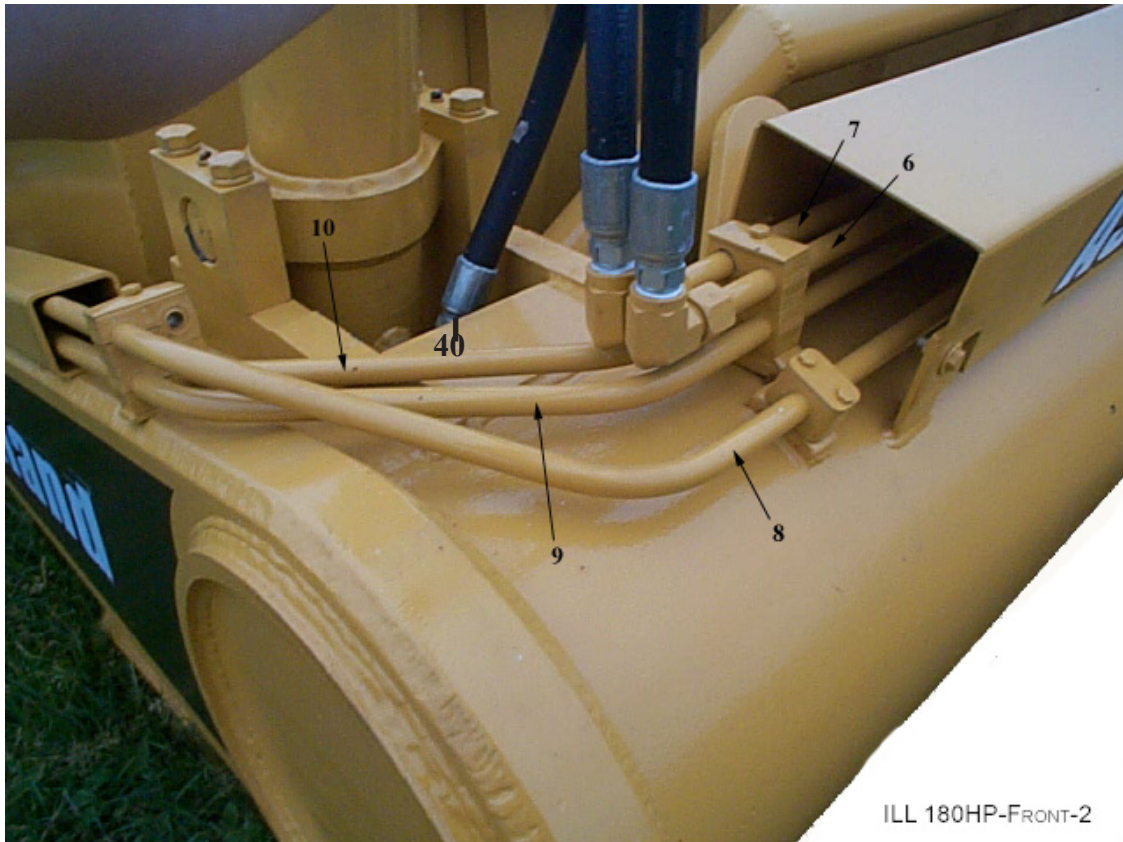
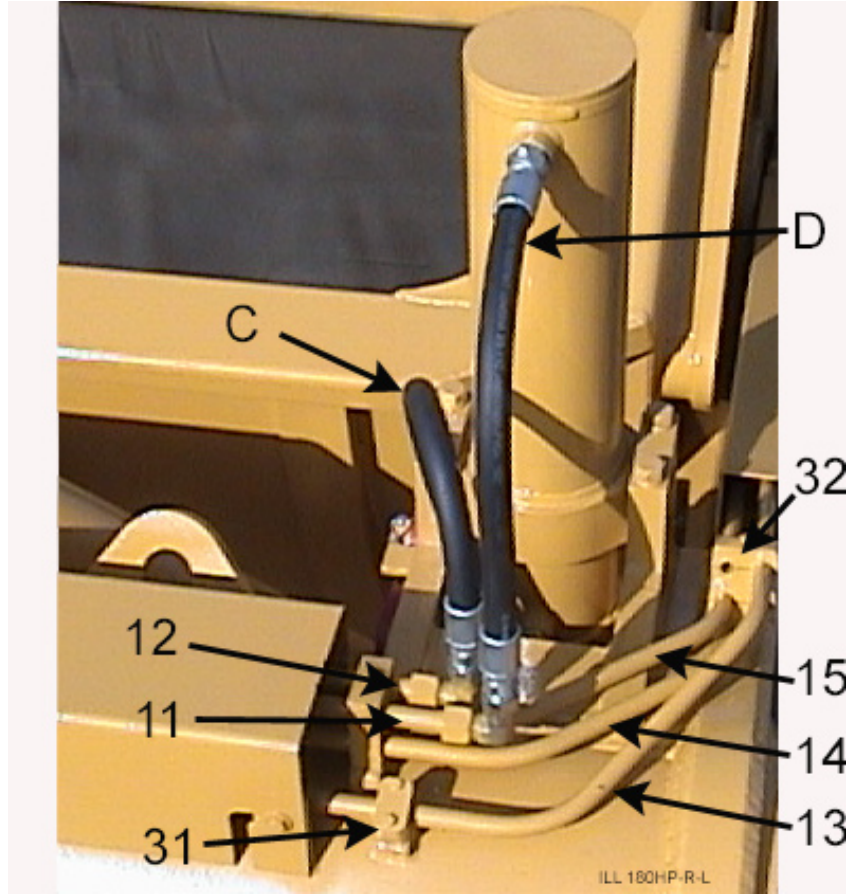

**Hydraulic Plumbing**  
**I-180TS2 s.n. 21403 & Up**

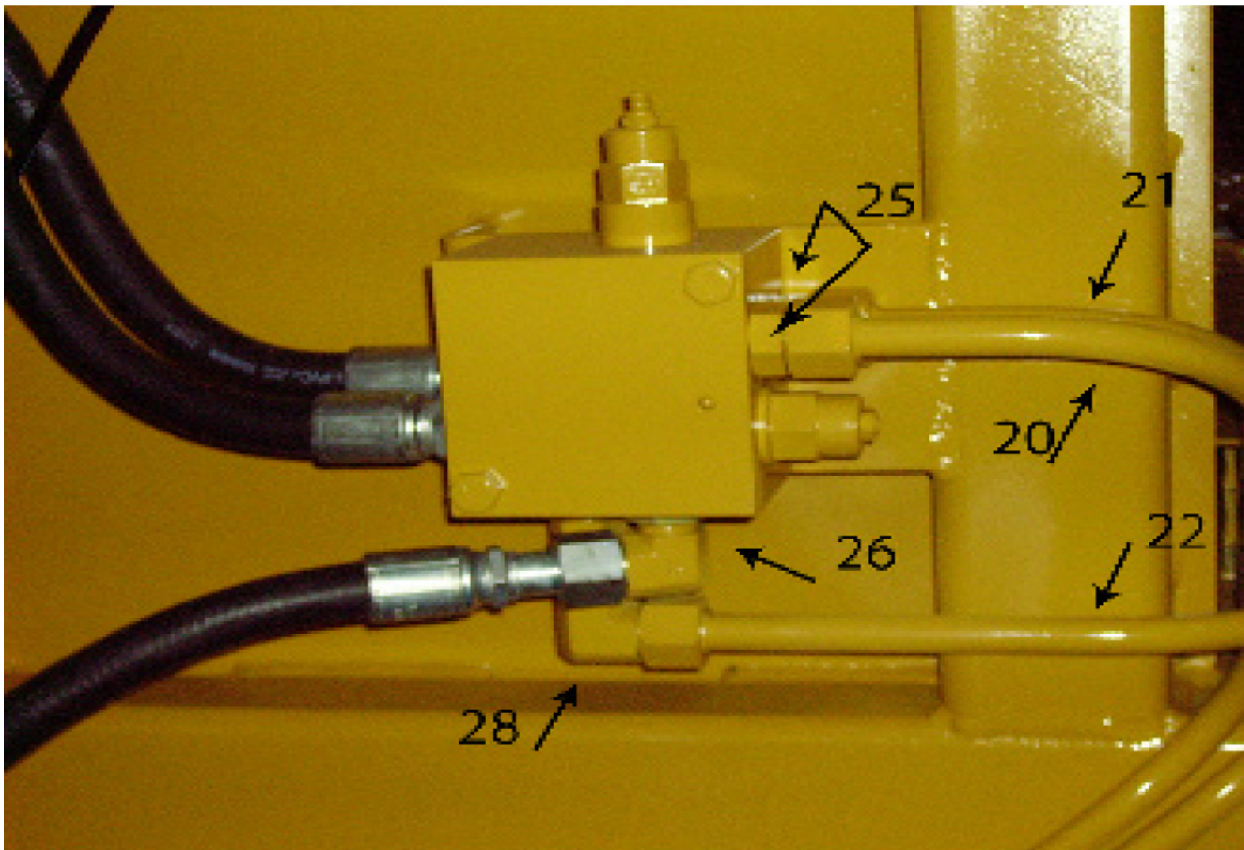
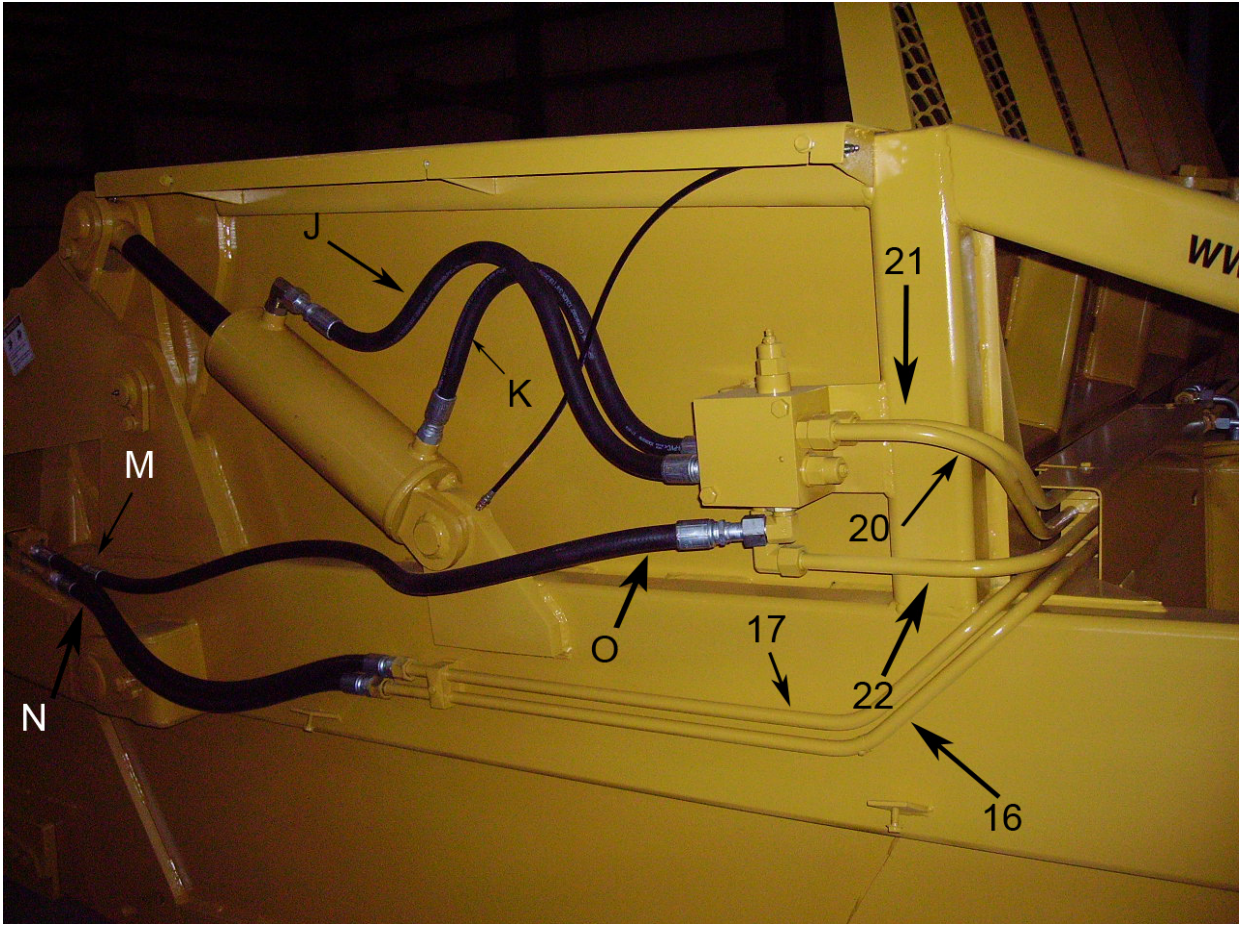

**Hydraulic Plumbing  
I-180TS2  
Front Section Center**

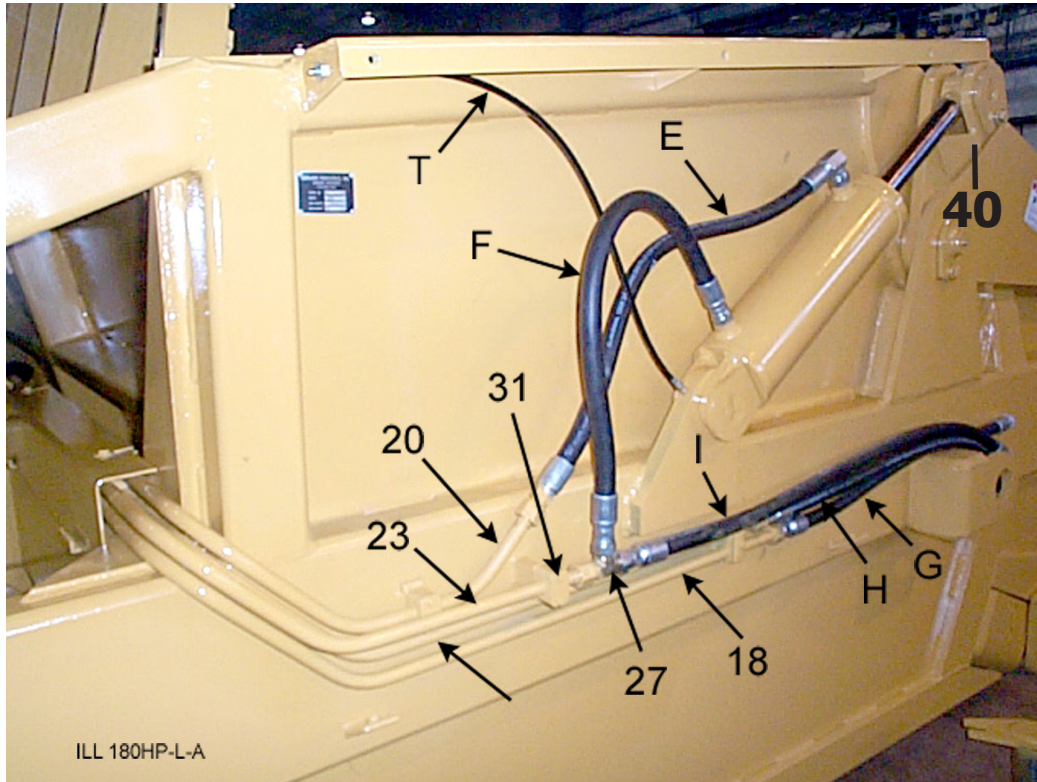
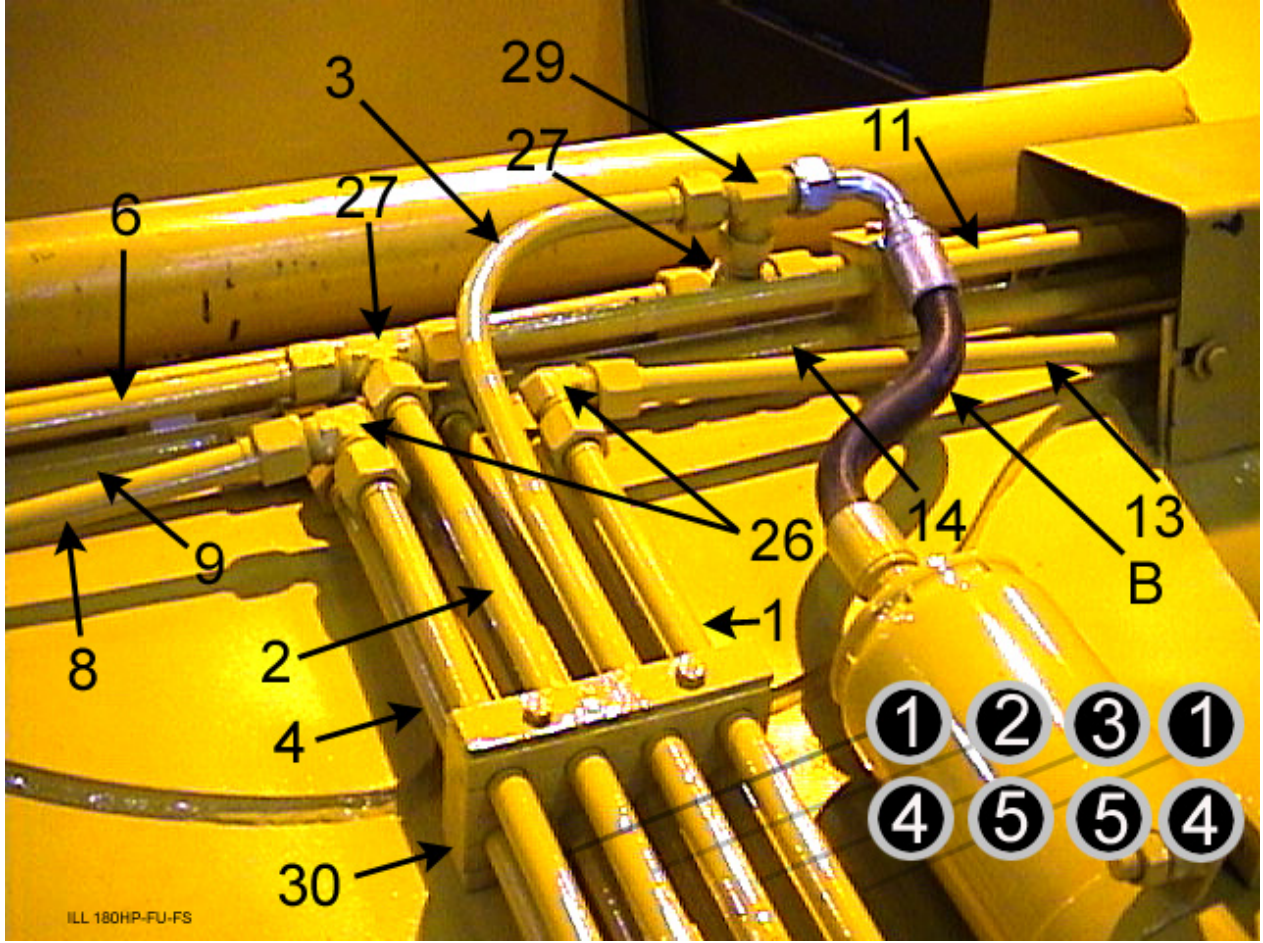

**Hydraulic Plumbing  
I-180TS2  
Front Section**

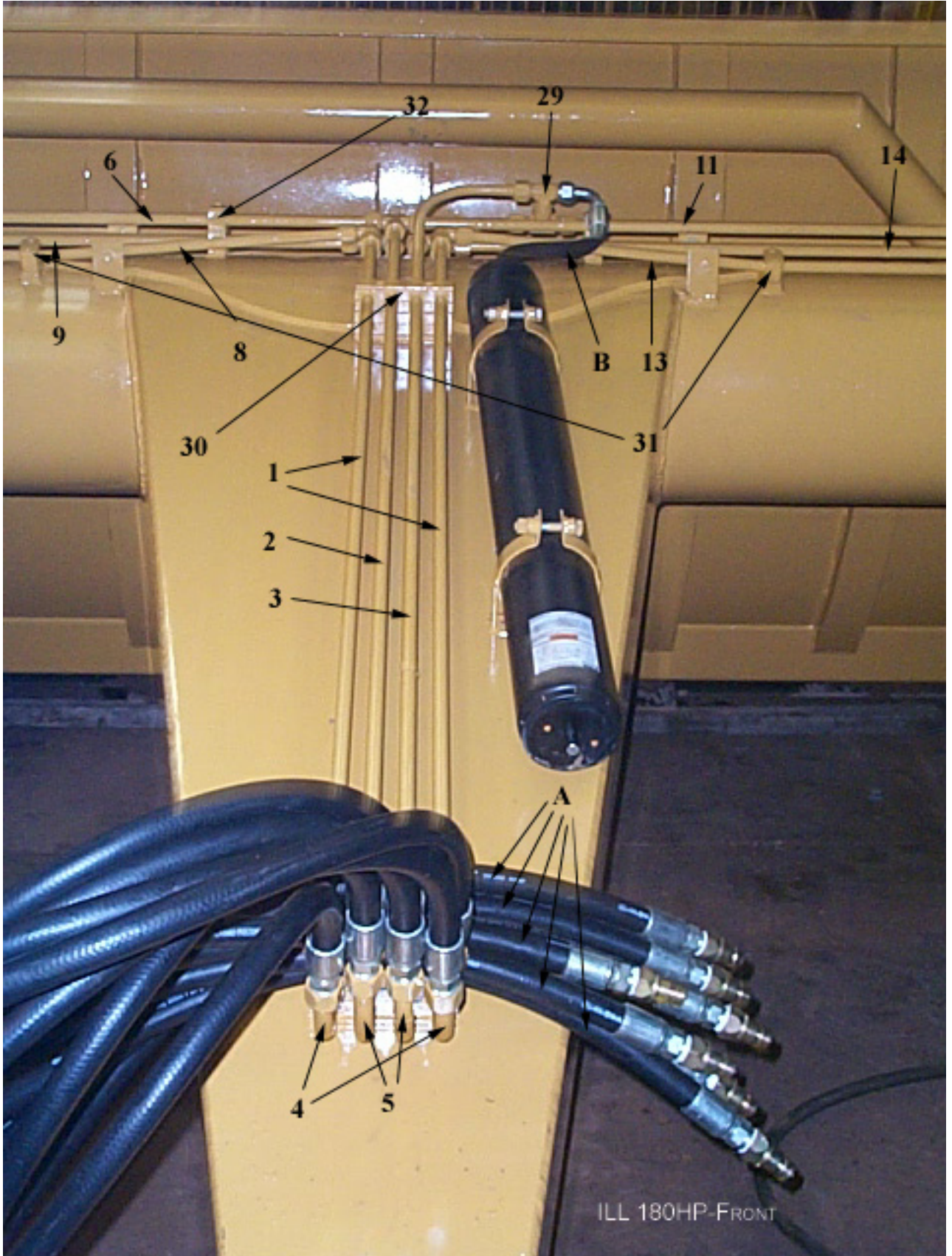

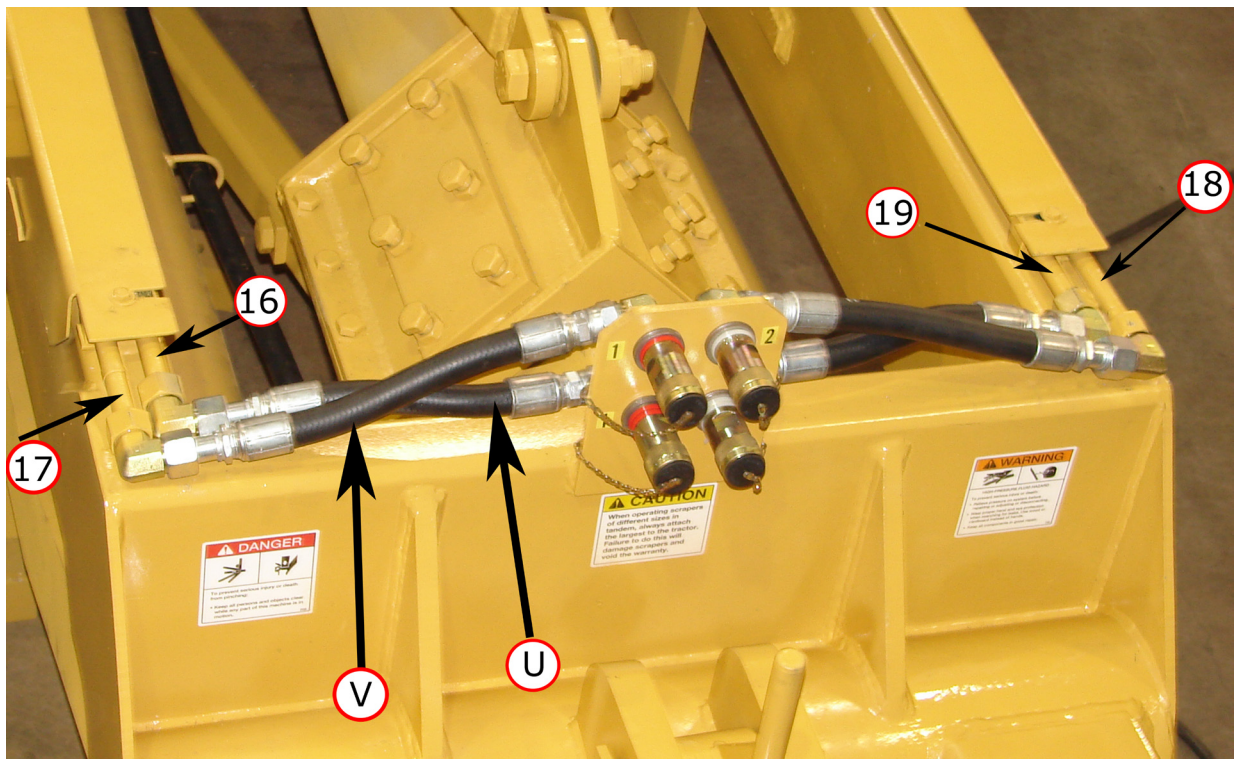
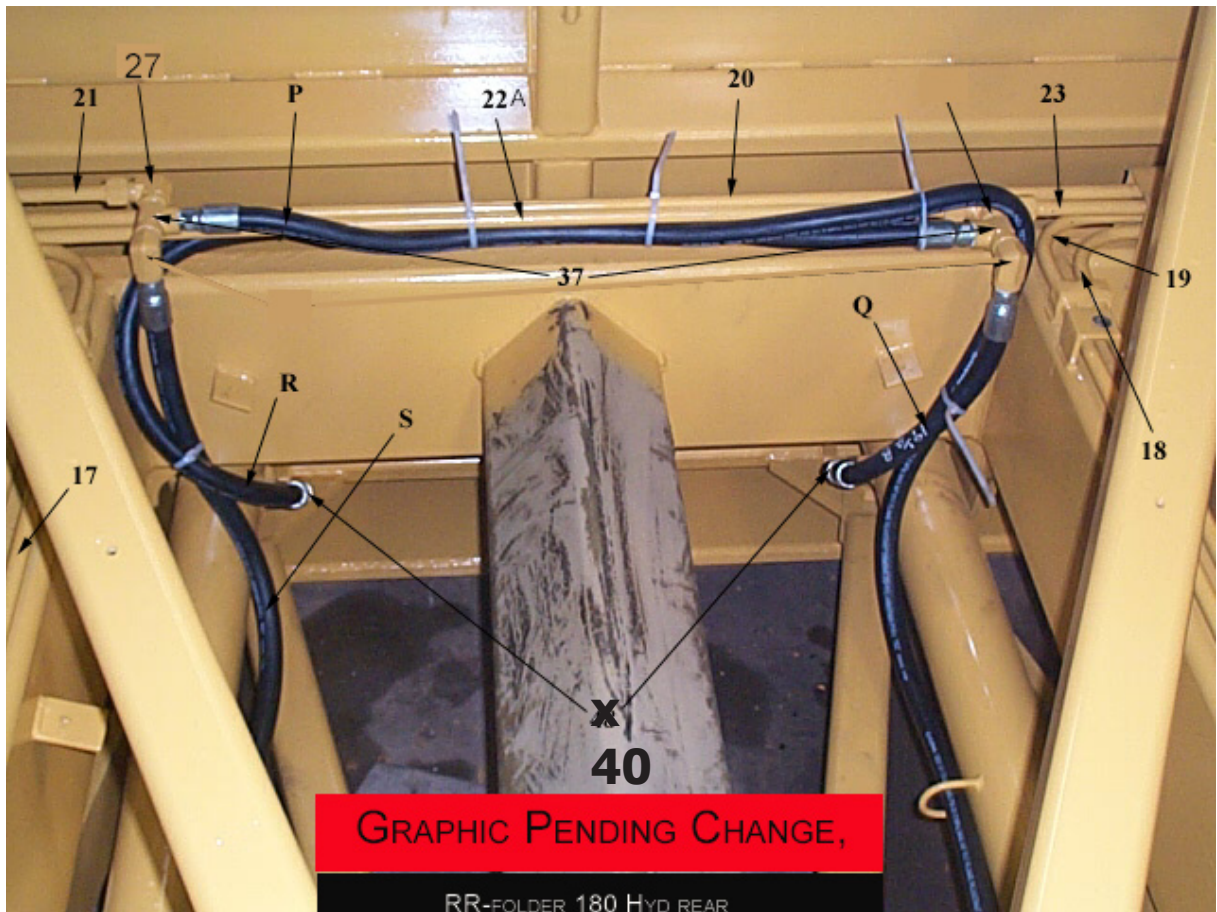

## PARTS LIST - HYDRAULIC PLUMBING - MODEL I-180TS2

Key No.	Part No.	Description
1	A125116	Tubing, Front, Top, Far Right and Far Left
2	A125117	Tubing, Front, Top, 2nd From Right
3	A125118	Tubing, Front, Top, 2nd From Left
4	A125117	Tubing, Front, Bottom, Outside
5	A125120	Tubing, Front, Bottom, Inside
6	A125121	Tubing, Top, Right Side
7	A125122	Tubing, Top, Right Side
8	A125123	Tubing, Top, Right Arm
9	A125123	Tubing, Bottom, Outer, Right Arm
10	A125123	Tubing, Bottom, Inner, Right Arm
11	A125126	Tubing, Top, Left Side
12	A125127	Tubing, Top, Left Side
13	A125123	Tubing, Top, Left Arm
14	A125123	Tubing, Bottom, Outer, Left Arm
15	A125123	Tubing, Bottom, Inner, Left Arm
16	A125132R	Tubing, Back, Outer Right
17	A125131L	Tubing, Back, Inner Left
18	A125132L	Tubing, Back, Outer Left
19	A125131R	Tubing, Back, Inner Right
20	A125190	Tubing, Wraps Around Back of Bowl
21	A125191	Tubing, Top, Around Left Side of Bowl
22	A125137	Tubing, Bottom, Around Left Side of Bowl
22A	A125138	Tubing, Middle Back
23	A125139	Tubing, Around Right Side of Bowl
24	A125174	Manifold Block, s.n. 21403 +
25	AHA-00069	ADAPTER: M ORS
26	AHA-00068	ADAPTER: 90 DEG. 3/4 M ORB X 3/4 M ORS
27	AHA-00066	ADAPTER: T 3/4 M ORS X 3/4 M ORS X 3/4 M ORS
28	AHA-00075	ADAPTER: 90 DEG. MORB M ORS LONG
29	AHA-00071	ADAPTER: T 3/4 M ORS X 3/4 F ORS X 3/4 M ORS
30	AHL-00004	CLAMP, HYD TUBING: 4 TUBE
31	AHL-00001	CLAMP, HYD TUBING: 1 TUBE
32	AHL-00022	CLAMP, HYD TUBING: 2 TUBE STACKING
33	AHL-00022 (2)	CLAMP, HYD TUBING: 3 TUBE STACKING
34	AHL-00002	CLAMP, HYD TUBING: 2 TUBE
35	AHF-00036	[IF UNIT HAS BREAKAWAY COUPLERS, YOU NEED] DUST CAPS
36	AHA-00068	ADAPTER: 90 DEG. 3/4 M ORB X 3/4 M ORS
37	NOT USED	
38	AHF-00023	FEMALE QUICK COUPLERS-RIDGE STYLE
39	AHF-00035	FEMALE QUICK COUPLERS-BREAKAWAY STYLE
40	AHA-00026	Adapter 90 degree Swivel 1-1/16 M or B x 3/4 FNPT

## PARTS LIST - HYDRAULIC PLUMBING - HOSES - MODEL I-180TS2

Key No.	Part No.	Description
A	A180H50S	3/4" x 75" Long, F ORS, M NPT, Double Braid High Pressure Hose
B	A180H70S	3/4" x 12" Long, M ORB, F ORS, Double Braid High Pressure Hose
C	A180H71S	3/4" x 21" Long, MPT, F ORS, Double Braid High Pressure Hose
D	A180H72S	3/4" x 28" Long, St. ORB, F ORS, Double Braid High Pressure Hose
E	A180H73S	3/4" x 34" Long, F ORS, 3/4 M ORS Double Braid High Pressure Hose
F	A180H74S	3/4" x 32" Long, F ORS, F ORS, Double Braid High Pressure Hose
G	A180H56S	3/4" x 41 5/8" Long, M ORS, M ORS, Double Braid High Pressure Hose
H	A180H57S	3/4" x 36 3/4" Long, M ORS, M ORS, Double Braid High Pressure Hose
I	A180H75S	3/4" x 50 3/4" Long, M ORS, F ORS, Double Braid High Pressure Hose
J	A180H76S	3/4" x 36" Long, 90 M ORS, M ORB, Double Braid High Pressure Hose
K	A180H77	3/4" x 30" Long, M ORB, M ORB, Double Braid High Pressure Hose
M	A180H78S	3/4" x 41 1/2" Long, F ORS, F ORS, Double Braid High Pressure Hose
N	A180H63S	3/4" x 36 3/4" Long, M ORS, M ORS, Double Braid High Pressure Hose
O	A180H62S	3/4" x 60" Lg, M ORS, 3/4 90 M ORS, Double Braid High Pressure Hose
P	A180H79S	3/4" x 121" Lg, 90 M ORB, 90 F ORS, Double Braid High Pressure Hose
Q	A180H80S	3/4" x 19 1/2" Lg, 90 M ORB, 90 F ORS, Double Braid High Pressure Hose
R	A180H81S	3/4" x 62" Lg 3/4 M ORB, 90 F ORS, Double Braid High Pressure Hose
S	A180H82S	3/4" x 79" Lg 3/4 M ORB, F ORS, Double Braid High Pressure Hose
T	A125020	32" x 1/8" M NPT x 1/8" M NPT Swivel, Remote Grease Line
U	A180H83S	3/4 x 11 Lg - 3/4 Fors, FJIC, Double Braid High Pressure Hose
V	A180H84S	3/4 x 9 1/2 Lg 3/4 FORS, FJIC, Double Braid High Pressure Hose



**IMPORTANT:** This Hyd. Manifold was intergrated into production April, 2006  
It replaces A125070 valve.  
For older machines see master parts book on Ashlandind.com.

## **HYDRAULIC MANIFOLD ASSEMBLY**

**A125174**

**S.N. 21403 & above**

### **SETTING THE APRON AND PUSHOFF VALVE**

The manifold block containing the pushoff sequence valve cartridge and apron sequence valve cartridge is used to control two hydraulic circuits with one hydraulic remote. when the tractor hydraulic remote is activated, oil flows first to the apron cylinders until they are fully extended. Once the cylinders are fully extended, the apron circuits' hydraulic pressure begins to increase. Once the pressure threshold is surpassed (which is adjustable. See adjustment section), the sequence valve diverts the oil flow to the pushoff's hydraulic circuit. Once the push off is completely extended the operator then reverses the tractors hydraulic remote. The counterbalance valve will hold the apron open until the push off is fully retracted. The Apron sequence valve then opens and allows the apron to close.

#### **Setting the valves:**

##### **STEP 1 PUSHOFF SEQUENCE VALVE**

Loosen the lock nut (9/16") on the sequence valve cartridge. Turn the setscrew (4mm) clockwise until the front apron rises before the push-off begins to advance. (Earth-mover should be empty) Turn the adjustment screw an additional 1/4 turn clockwise and tighten jam nut.

##### **STEP 2 Counter Balance VALVE**

Loosen the lock nut (9/16") on the counterbalance valve cartridge. Turn the set-screw (4mm) counter-clockwise until the apron holds in a raised position while rear gate is being retracted. Turn adjustment screw an additional 1/4 turn, tighten jam nut. DO NOT tighten adjusting screw more than necessary.

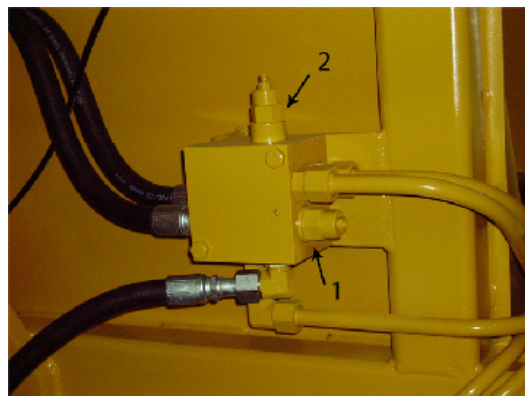

<b>ITEM #</b>	<b>PART NO.</b>	<b>DESCRIPTION</b>
1	A125162-01	COUNTER BALANCE CARTRIDGE
2	A125162-02	SEQUENCE CARTRIDGE

# I-180 TS Hydraulic Schematic tractor

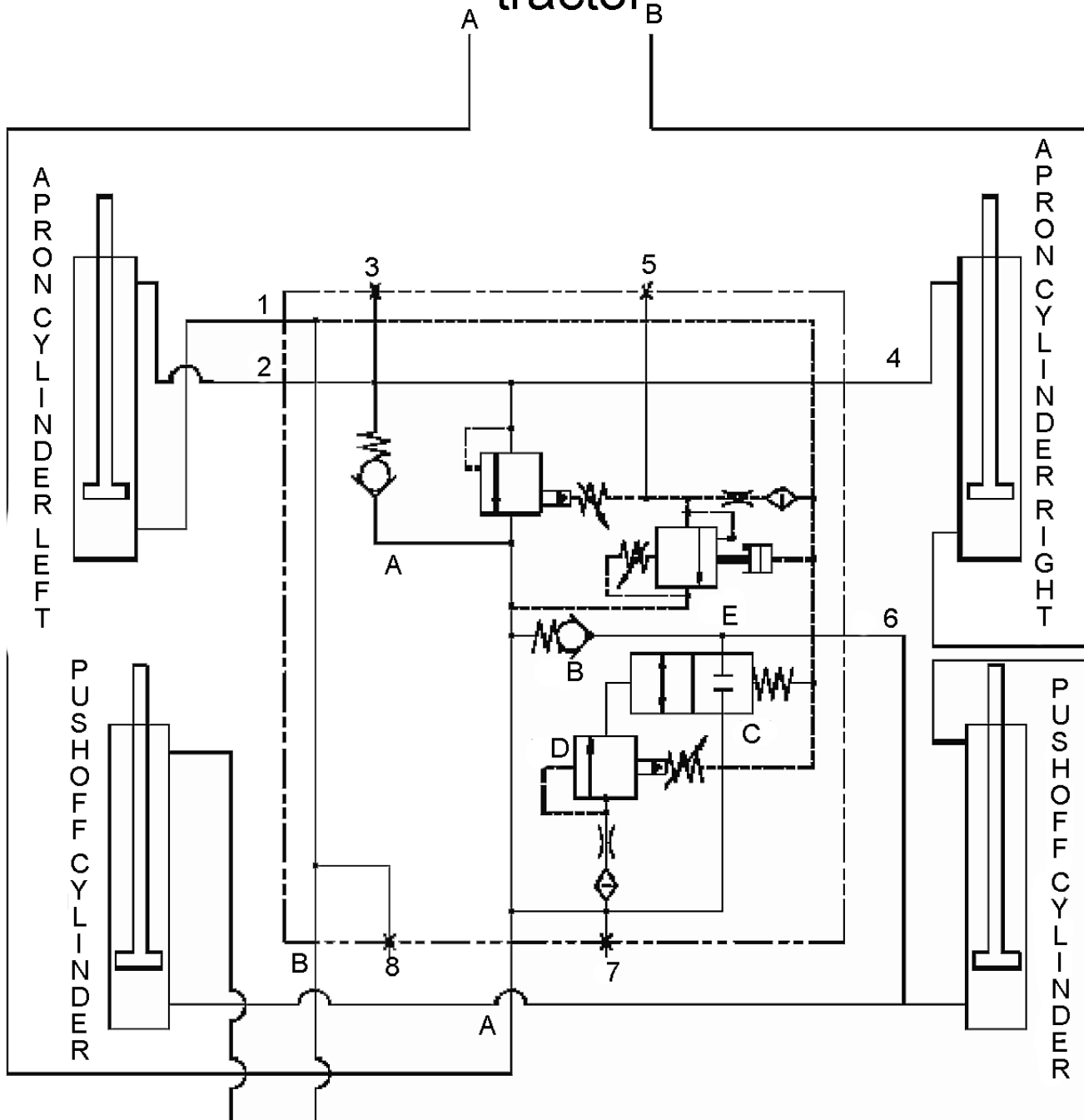

**PORT 7 & 8 ARE PRESSURE TEST PORTS #6SAE**

<b>KEY</b>	<b>DESCRIPTION</b>
A	Counter Balance Valve
B	Check Valve
C	Directional Control Valve
D	Sequence Valve

# GREASE LOCATIONS

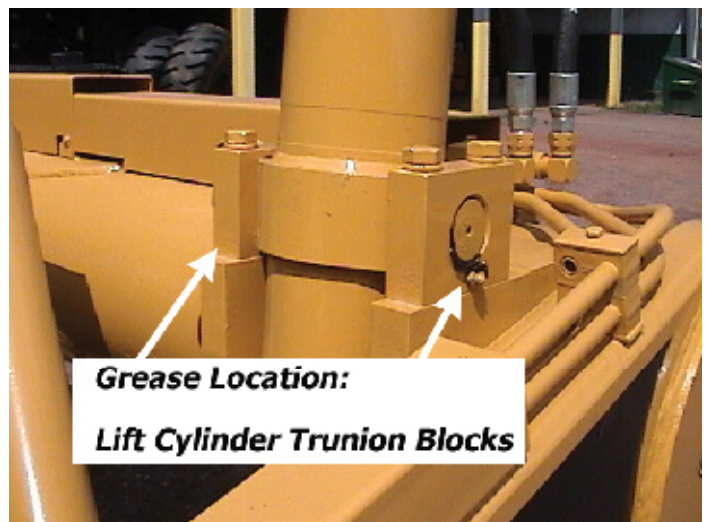
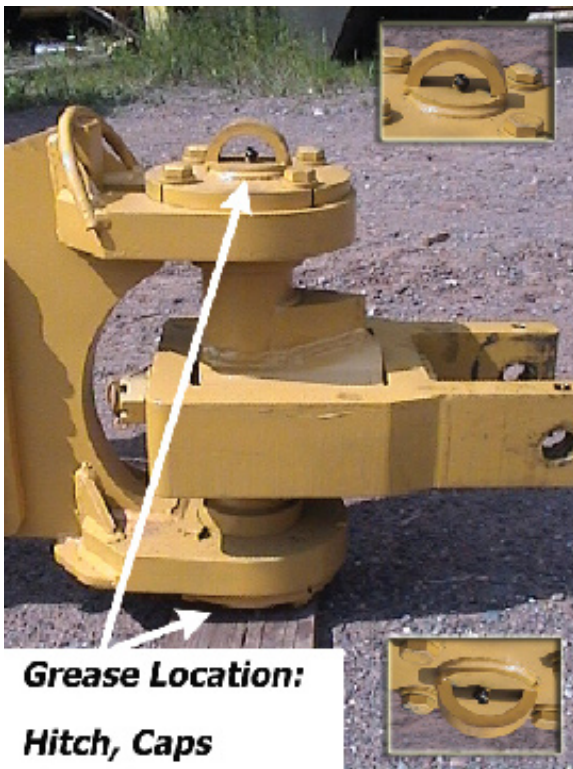

# GREASE LOCATIONS

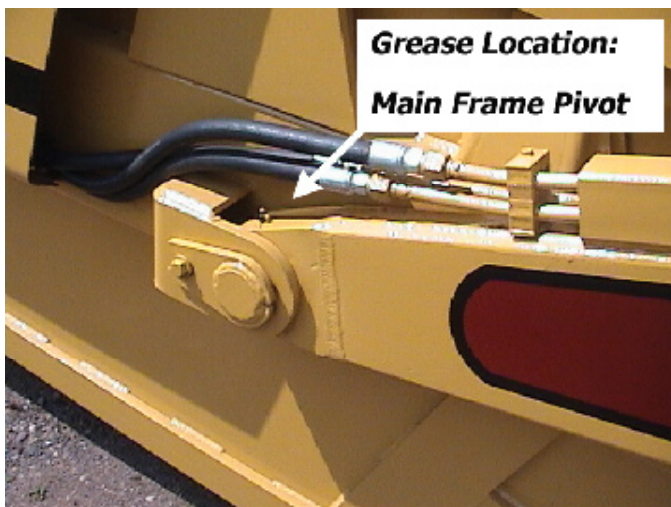
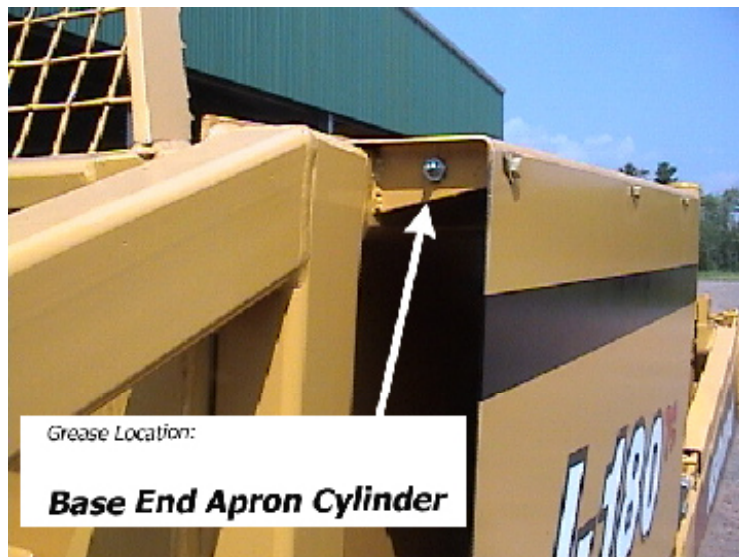
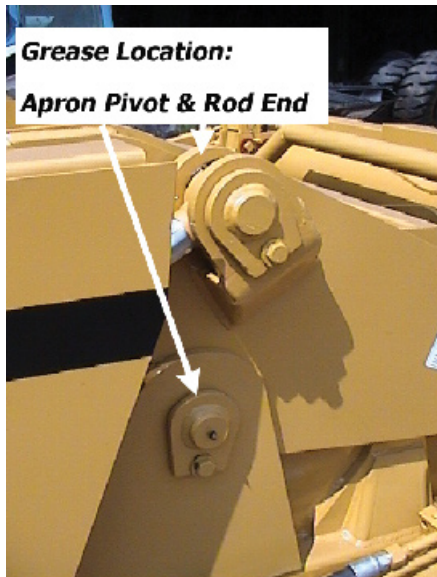

**All Grease areas should be cleaned prior to greasing. Lack of grease within these pivoting areas will void your factory warranty.**

# MAINTENANCE CHECKLIST

---

1. Grease all zerks.
  - a) Every 5 hours of operation.
  - b) See Lubrication Points section on next page.
  
2. Greasing the hubs.
  - a) Re-pack wheel bearings after 600 hrs of operation.
  - b) Completely clean grease out of hub and bearings every 1200 hours of operation.
  
3. Check tire pressure.
  - a) 29.5 – 25, 28-ply tire requires a tire pressure of 45-50 psi.  
If pressure drops, first secure valve stem, and if pressure continues to drop, contact Ashland Industries.
  
4. Check all pins for signs of wear.
  - a) Daily
  
5. Check and retighten all bolts.
  - a) After initial 10 hours of use.
  - b) Again after 50 hours of use.
  - c) See Torque Specifications on next page.
  
6. Inspect cutting edges.
  - a) Daily
  - b) Replace cutting edges when center blade has been worn to approximately 6" and side edges worn to approximately 4".

---

 **CAUTION!** Failure to replace worn cutting edges may result in unnecessary wear to the earthmover sides and floor.

---

Note: Please specify left or right "L" shaped cutting edges when ordering replacements.

# HYDRAULIC SYSTEM

---

## **Standard Two-Circuit Hydraulic Plumbing**

The apron cylinders and the push-off cylinder are controlled on the same circuit with the sequence of the operation controlled by the hydraulic manifold which contains a sequence and counterbalance valve. The other hydraulic circuit controls the lift cylinders on the earthmover.

**\*To adjust the sequence valve, see Troubleshooting section.**

### **CAUTION!**

Relieve all hydraulic pressure before working on the hydraulic system.

---

### **WARNING!**



**High Pressure Fluid Hazard – To prevent serious injury or death from high pressure fluid:**

- a) **Relieve pressure on hydraulic system before repairing, adjusting, or disconnecting.**
  - b) **Wear proper hand and eye protection when searching for leaks.**
  - c) **Keep all components in good repair.**
- 
-

# TORQUE SPECIFICATIONS

---

<i>Grade 8</i>	
<i>Bolt Diameter</i>	<i>Torque ft-lbs</i>
1/4"	12
5/16"	25
3/8"	45
7/16"	70
1/2"	110
9/16"	150
5/8"	220
3/4"	380
7/8"	600
1"	900
1-1/8"	1280

## LUBRICATION

---

1. Grease all zerks every 8 hrs of operation with high quality, general-purpose grease.
  - a) Grease until grease flows from around pin.

### Lubrication Points

1. Hitch – Horizontal and vertical pins.
2. Lift Cylinders – Rod end; Both left & right sides.
3. Hold-down Rollers – Both left & right sides.
5. Front Arm Pivot Joint – Both left & right sides.
6. Apron Pivot Pin; Both left & right sides.
7. Lift Cylinders – Trunnion Mount Blocks; Both left & right sides
8. Lift Cylinders – Trunnion Mount Blocks; Both left & right sides

# TROUBLESHOOTING

---

## Introduction

---

With proper care and maintenance, the I-180TS will give many years of reliable service. When a situation arises where the earthmover performance is not satisfactory, this section will give some pointers on finding and correcting the problem.

---

### Grease zerk will not take grease.

---

1. Grease zerk plugged.
  - a) Remove and replace grease zerk.
2. Pin is frozen.
  - a) Remove, clean, and inspect pin.
  - b) Replace pin if necessary.
3. Bushing grease passage is not aligned with grease zerk.
  - a) Remove, clean, inspect, and realign bushing.
  - b) Replace bushing if necessary and realign.

---

### Cylinders will not hold in preset position, i.e. the cylinder creeps.

---

1. Seals leaking internally.
  - a) Remove and replace seal kit.

---

### Machine cuts unevenly.

---

1. Cutting edges worn unevenly.
  - a) Replace cutting edges.
2. Improperly inflated tires.
  - a) Check air pressure in tires.



# Limited Warranty Statement

Ashland Industries Inc. warrants each new product to be free from defects in material and workmanship. This warranty is applicable only for the normal service life expectancy of the product or components, not to exceed **six consecutive months** from the date of delivery of the new Ashland Industries product to the purchaser, or the date the product is first put into service via a rental agreement or other means, whichever occurs first.

The major components of swivel hitches used on Industrial series scrapers are warranted for three consecutive months from the date of delivery of the new Ashland Industries product to the purchaser, or the date the product is first put into service via a rental agreement or other means, whichever occurs first, except those components described below.

Genuine Ashland Industries Inc. replacement parts and components will be warranted for 30 days from date of purchase, or the remainder of the original equipment warranty period, whichever is longer.

Under no circumstances will it cover any merchandise or components thereof, which in the opinion of the company, has been subjected to misuse, unauthorized modification, alterations, an accident or if repairs have been made with parts other than those obtained through Ashland Industries Inc.

Ashland Industries Inc. in no way warrants Tires since their respective manufacturer warrants these items separately. Please call Ashland Industries Inc. to receive phone numbers of tire suppliers.

Ashland Industries Inc. in no way warrants wearable items such as cutting edges, front dolly wheel balls, socket halves, rollers, bushings, yoke hitch pins, hitch bushings, etc..

Our obligation under this warranty shall be limited to repairing or replacing, free of charge to the original purchaser, any part that, in our judgement, shall show evidence of such defect, provided further that such part shall be returned within 30 days from the date of failure to Ashland Industries Inc. routed through the dealer and distributor from whom the purchase was made, transportation charges prepaid. Upon warranty approval proper credits will be reimbursed for transportation.

This warranty shall not be interpreted to render Ashland Industries Inc. liable for injury or damages of any kind or nature to person or property. This warranty does not extend to the loss revenue, extra labor cost associated with downtime, substitute machinery, rental or for any other reason.

Except as set forth above, Ashland Industries Inc. shall have no obligation or liability of any kind on account of any of its equipment and shall not be liable for special or consequential damages. Ashland Industries Inc. make no other warranty, expressed or implied, and, specifically, Ashland Industries Inc. disclaims any implied warrant or merchantability or fitness for a particular purpose. Some states or provinces do not permit limitations or exclusions of implied warranties or incidental or consequential damages, so the limitations or exclusion in this warranty may not apply.

This warranty is subject to any existing conditions of supply which may direct affect our ability to obtain materials or manufacture replacement parts.

Ashland Industries Inc. reserves the right to make improvements in design or changes in specifications at any time, without incurring any obligation to owners of units previously sold

No one is authorized to alter, Modify or enlarge this warranty nor the exclusion, limitations and reservations.

Ashland Industries Inc.  
Warranty Department