

Ashland

EARTHMOVERS



Model 25

PARTS MANUAL

Version 3-2007

Ashland Industries Inc.
1115 Rail Drive
P.O. Box 717
Ashland, WI. 54806
Ph: 877-634-4622 Toll Free
Ph: 715-682-4622
Fx: 715-682-9717
www.ashlandind.com

MEMBER



CONSTRUCTION INDUSTRY
MANUFACTURERS ASSOCIATION





Model 25 Scraper

HOW TO ORDER PARTS:

IMPORTANT

Parts must be ordered through your local authorized ASHLAND dealer. Be sure to state MODEL and SERIAL NUMBER of your machine, PART NUMBER, DESCRIPTION and QUANTITY needed. Unless this is done, we cannot provide prompt service or assure shipment of the correct parts.



Ashland Industries weldable replacement parts are available to rebuild, modify or update your scraper to current factory specifications.

INDEX

PAGE NO.

- Page 3. Safety Guidelines
- Page 4. Assembly Instructions
- Page 5. Frame, Pole, and Axle Assembly
- Page 6. Bucket & Apron Assembly
- Page 7. Actuating Assembly
- Page 8. Wheel, Hub and Spindle
- Page 9. Hydraulic Cylinder 3 1/2" x 16"
- Page 10. PMC-5500D Series
- Page 11. Hydraulic Cylinder (Opt. Hi-Press) 2 1/2" x 16"
- Page 12. Warranty Statement



SAFETY SIGNAL WORDS

Note the use of the signal words DANGER, WARNING and CAUTION with the safety messages. The appropriate signal word for each has been selected using the following guidelines:



DANGER: Indicates an imminently hazardous situation that, if not avoided, will result in death or serious injury. This signal word is to be limited to the most extreme situations typically for machine components which, for functional purposes, cannot be guarded.



WARNING: Indicates a potentially hazardous situation that, if not avoided, could result in death or serious injury, and includes hazards that are exposed when guards are removed. It may also be used to alert against unsafe practices.



CAUTION: Indicates a potentially hazardous situation that, if not avoided, may result in minor or moderate injury. It may also be used to alert against unsafe practices.



GENERAL SAFETY GUIDELINES

Safety of the operator is one of the main concerns in designing and developing a new piece of equipment. Designers and manufacturers build in as many safety features as possible. However, every year many accidents occur which could have been avoided by a few seconds of thought and a more careful approach to handling equipment. You, the operator, can avoid many accidents by observing the following precautions in this section. To avoid personal injury, study the following precautions and insist those working with you, or for you, follow them.

Replace any CAUTION, WARNING, DANGER or instruction safety decal that is not readable or is missing. Location of such decals is indicated in this booklet.

Do not attempt to operate this equipment under the influence of drugs or alcohol.

Review the safety instructions with all users annually.

This equipment is dangerous to children and persons unfamiliar with its operation. The operator should be a responsible adult familiar with farm machinery and trained in this equipment's operations. **Do not allow persons to operate or assemble this unit until they have read this manual and have developed a thorough understanding of the safety precautions and of how it works.**

To prevent injury or death, use a tractor equipped with a Roll Over Protective System (ROPS). Do not paint over, remove or deface any safety signs or warning decals on your equipment. Observe all safety signs and practice the instructions on them.

Never exceed the limits of a piece of machinery. If its ability to do a job, or to do so safely, is in question - **DON'T TRY IT.**

ASSEMBLY INSTRUCTIONS FOR MODEL 25 SCRAPER

1. A suitable hoist or lift should be available for assembly.
2. Pack wheel bearings with grease and install hubs to axle spindles.
3. Attach actuating frame to rear holes of the bucket using two 1 ¼" x 2-7/8" pins. Install pins with washer and cotter pin on the inside of the bucket.
4. Install actuating bars into the front holes in the bucket. In doing so, be sure that the cast roller on the opposite end of the actuating arm is in the up position and facing inward. Insert 1 ¼" x 2-7/16" pin (with tab type head) from the inside of the bucket. Secure with 5/8" x 1 ¼" bolt through the bucket side with the lock nut to the outside.
5. Connect a short chain from the cutting edge to the cross pipe of the actuating frame, then raise the bucket and actuating frame assembly over the main frame and lower until the front actuating bars can be connected to the double ear brackets on the front cross member of the frame. Secure with 1 ¼" x 2 ¾" pins and cotter pins.
6. Continue to lower the bucket and actuating assembly in place so that the front holes on the actuating frame aligns with the 1 ½" hole in the bearing on each side of the main frame. Secure with 1 ½" x 5-5/8" pins on each side. Lock the pins in place by turning the pin until the hole in the straps aligns with the threaded hole in the actuating frame, then secure with ½" x 1" capscrews and lock washer.
7. Raise the front apron over the bucket and lower into position so that the holes in the arms on the apron align with the holes in the bucket. Secure with the 1 ¼" to 1" threaded shoulder pin. The threaded end goes inside the bucket. Install lock nut, tighten securely.
8. Install hydraulic cylinders to main frame and actuating frame with rod end to actuating frame. Be sure that the grease fittings in the rod cross tube are facing upward.
9. Install a 3/8" 90° swivel adapter into the front port of each cylinder.
10. Connect a 3/8" hose to the rear port of each cylinder and to the pipe line on the rear cross frame. Be sure both hoses from the rear ports are connected to the same pipe line.
11. Connect the two 3/8" x 33" hoses from the swivel adapter on the front of each cylinder to the remaining pipe on the rear cross frame.
12. Raise rear of frame and install wheels to hubs. Also install wheels to front axle on 25D model.
13. 25D: Raise front of frame and roll axle assembly directly under the gooseneck. Place the socket halves around the ball swivel on axle so that the half with the zerk hole is to the rear. Lower the frame into place so that the socket halves seat into the gooseneck. (If necessary, clamp halves together with C-clamp while lowering into place.) Secure in place with 5/8" x 4" bolts through gooseneck and cast sockets. Install long shank grease fitting into hole in back side of gooseneck.

ASHLAND INDUSTRIES, INC.

FRAME, POLE AND AXLE ASSEMBLY

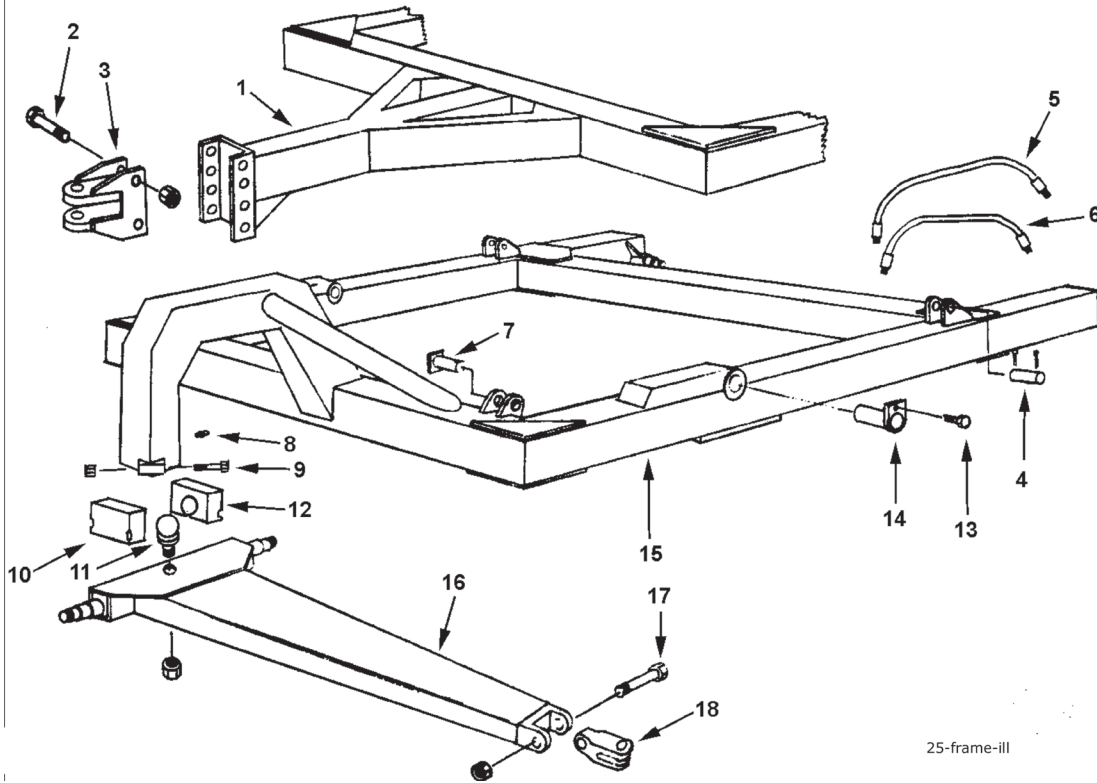

25-frame-ill

KEY NO.	PART NO.	DESCRIPTION
1	A2501	Frame, two wheel model
2		Bolt, 5/8" x 6" w/ nut & lock washer
3	A3304	Hitch
4	A2508	Pin, 1" x 3 -1/4", cotter both ends
5	A22H02	Hydraulic hose, 3/8" x 33"
6	A22H01	Hydraulic hose, 3/8" x 24"
	A22H03	Swivel Adapter, 3/8", 90°
	A22H04	Swivel Adapter, 3/8", straight
7	A3310	Pin, 1-1/4" x 2-7/8"
8	A2206	Zerk, 1/8" NPT (straight long shank)
9		Bolt, 5/8" x 4" w/ nut & lock washer
10	A30004	Cast socket half, front
11	A2203A	Ball swivel
		Nut, 1-1/4" NF
12	A30005	Cast socket half, rear w/ zerk hole
13		Capscrew, 1/2" x 1" NC
14	A2502	Pin, 1-1/2" x 5-5/8"
15	A2503A	Frame, four wheel model
16	A2202A	Pole and axle assembly
17		Bolt, 1" x 6" NF w/ lock nut
18	A2207	Swivel hitch
***	A022977-2	Hitch, Tractor 3 point, Category 2
***	A022977-3	Hitch, Tractor 3 point, Category 3

BUCKET & APRON ASSEMBLY

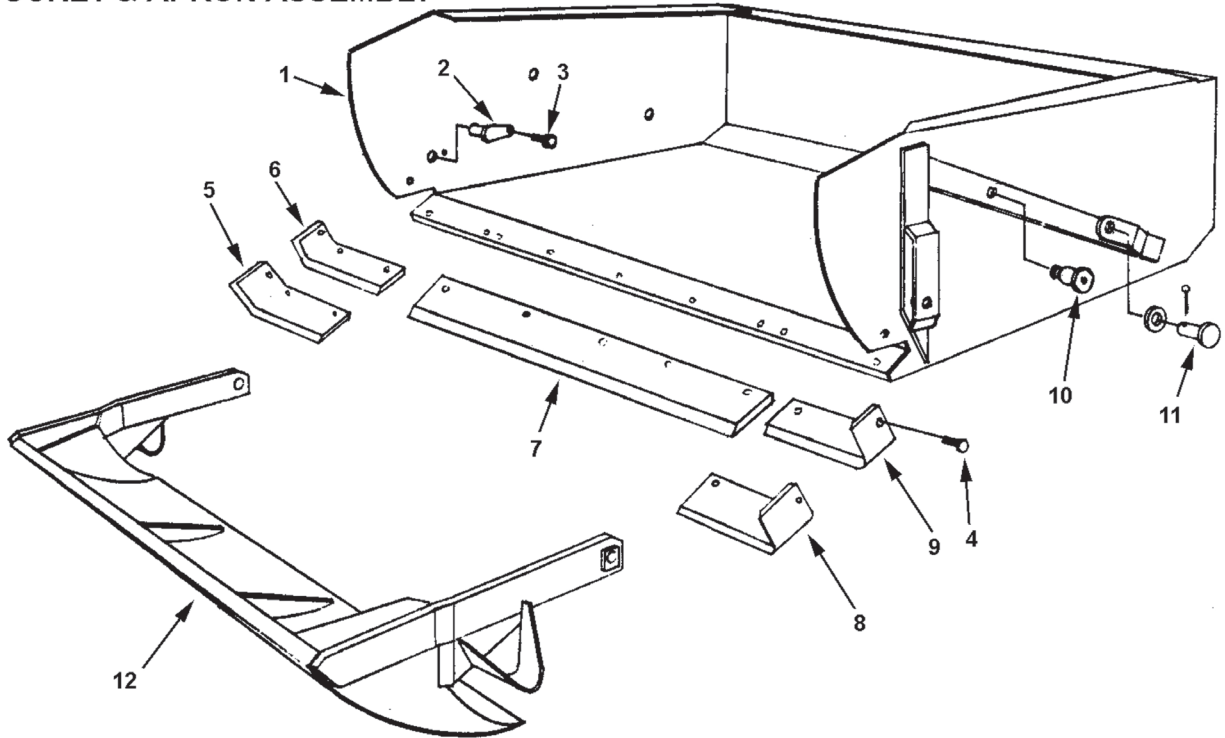

25-apron-ILL

KEY NO. PART NO. DESCRIPTION

KEY NO.	PART NO.	DESCRIPTION
1	A2504	Bucket
2	A4505	Pin, 1-1/4" x 2-3/8" w/ locking head
3		Bolt, 1/2" x 1" NC w/ nut & lock washer
4		Plow bolts, 1/2" x 1-1/4" w/ nut (2 req'd/Blade)
		Plow bolt, 1/2" x 1-3/4" w/ nut (9 req'd)
5	A2225	Right cutting edge, 6" (optional)
6	A2224	Right cutting edge, 4"
7	A30021	Center cutting edge, 6"
8	A2222	Left cutting edge, 6" (optional)
9	A2221	Left cutting edge, 4"
10	A30020	Shoulder pin, 1-1/4" to 1" NF w/ ctsk hole in head
		Nut, 1" NF nylon insert lock type
11	A3310	Pin, 1-1/4" x 2-7/8"
		Narrow rim washer, 1-1/4" ID
		Cotter pin, 1/4" x 2"
12	A3317	Apron

ACTUATING ASSEMBLY

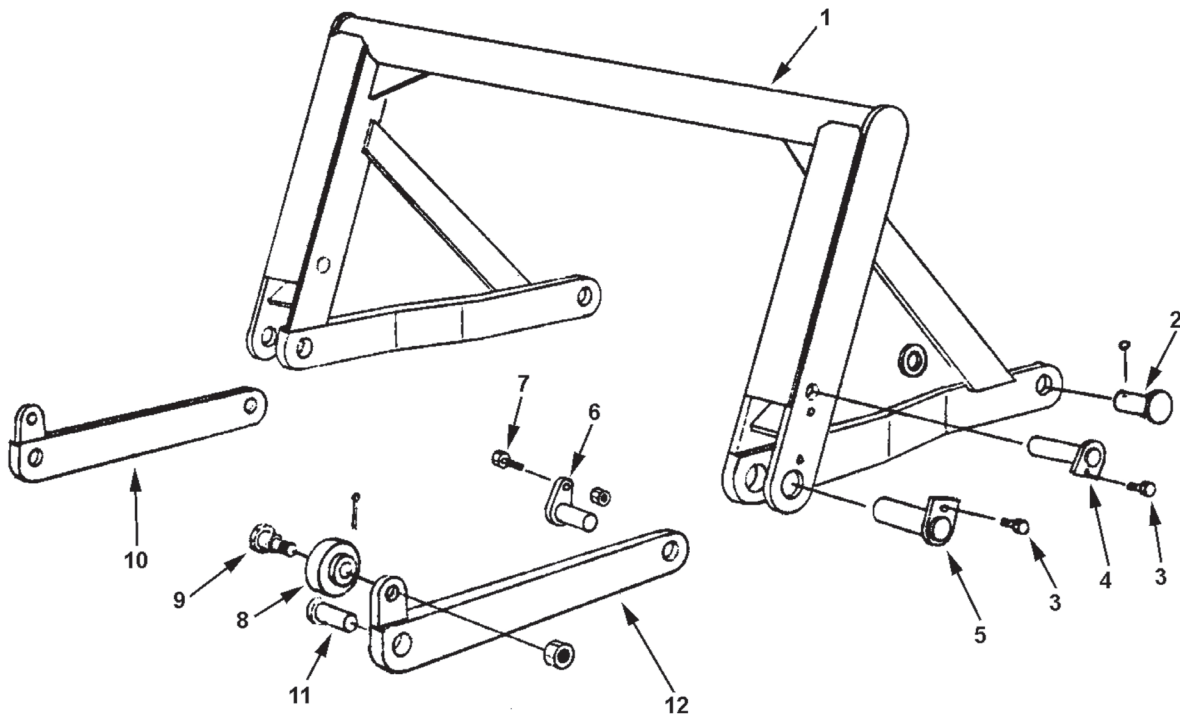

25-act-frame-ill.psd

KEY NO.	PART NO.	DESCRIPTION
1	A2506	Actuating frame
2	A3310	Pin, 1-1/4" x 2-7/8". cotter one end
		Narrow rim washer, 1-1/4" ID
		Cotter pin, 1/4" x 2"
3		Capscrew, 1/2" x 1" NC
		Lockwasher, 1/2"
4	A3318	Pin, 1" x 5-5/8", tab head
5	A2502	Pin, 1-1/2" x 5-5/8"
6	A4505	Pin, 1-1/4" x 2-3/8" w/ locking head
7		Bolt, 1/2" x 1" NC w/ nut & lockwasher
8	A30002	Roller
9	A30003	Shoulder pin, 2-1/2" shoulder length
		Nut, 1" NF nylon insert lock type
10	A3312	Actuating arm, right
11	A3310	Pin, 1-1/4" x 2-7/8"
		Cotter pin, 1/4" x 2"
12	A3313	Actuating arm, left

WHEEL, HUB, & SPINDLE

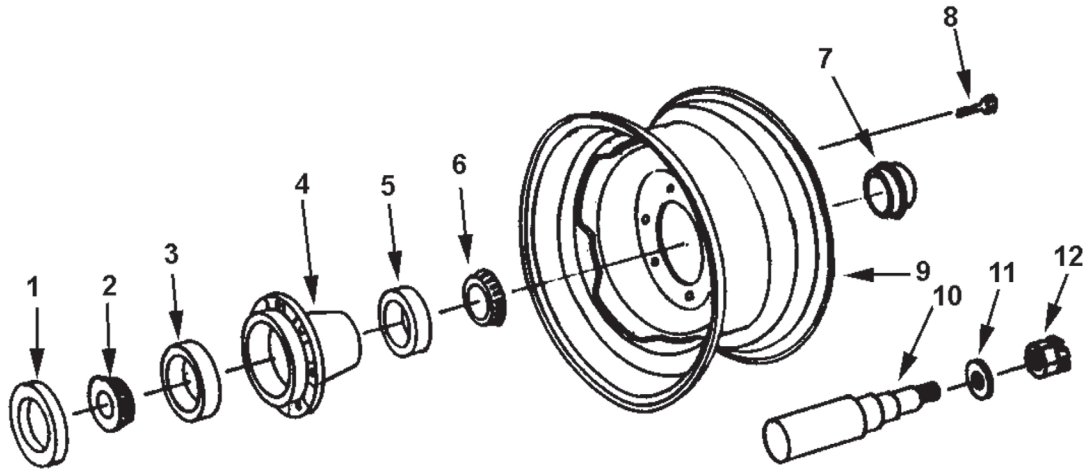

25-wheel-III

KEY NO.	PART NO.	DESCRIPTION
1	A2229	Grease seal (CR 22870)
2	A2230	Bearing cone (inner) (Timken 342A)
3	A2231	Bearing cup (inner) (Timken 332)
4	A2232	Hub, less bearings
5	A2233	Bearing cup (outer) (Timken 14276)
6	A2234	Bearing cone (outer) (Timken 14137A)
7	A2235	Hub cap
8	A2236	Wheel bolt
9	A3319	Wheel, 15" x 6" Standard
	A2237	Wheel, 14" x 6" (early model)
10	A2238	Spindle, welded
11	A2239	Washer, special 7/8" flat
12		Nut, 7/8" NF castellated
		Cotter pin, 3/16" x 1-1/2"

HYDRAULIC CYLINDER
3-1/2" BORE X 16" STROKE
(STANDARD)

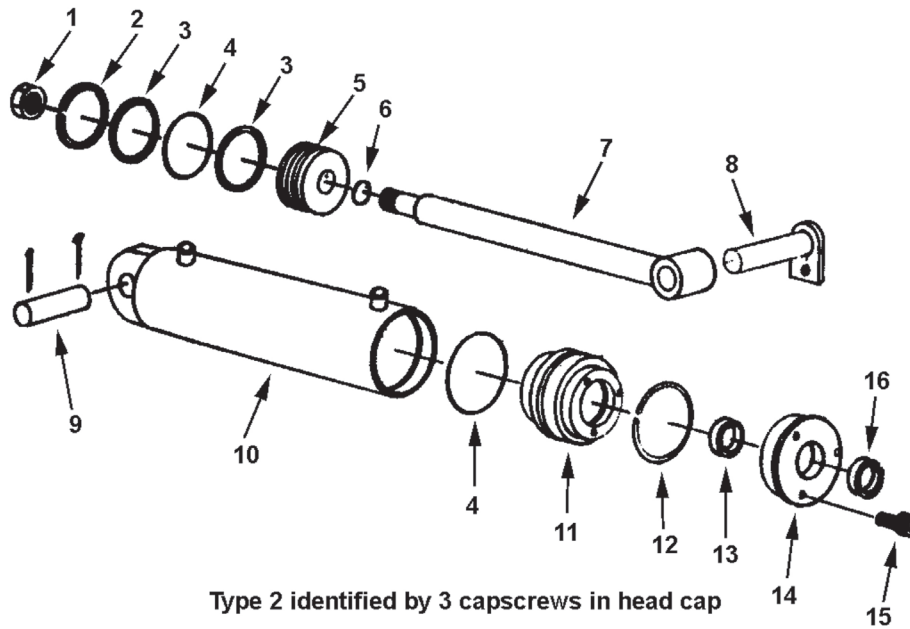

25-cyl-lift-ILL

MODEL A3516H1

KEY NO.	PART NO.	DESCRIPTION
1	A22H05	Piston nut, 3/4" NF
2	A22H06	Cast iron ring, 3-1/2" OD
3	A22H07	Back up washer, 3-1/2" OD
4	A22H08	O-ring seal, 3-1/2" x 3/16"
5	A22H09	Piston, 3-1/2"
6	A22H10	Piston gasket, 3/4" ID
7	A22H11	Shaft, 1-1/2" dia.
8	A3318	Pin, 1" x 5-5/8" tab head
9	A2508	Pin, 1" x 3-1/4"
		Cotter pin, 3/16" x 1-1/2"
10	A22H12	Barrel assembly, 3-1/2" ID
11	A22H13	Head gland, 3-1/2"
12	A22H14	Retainer ring
13	A22H15	O-ring
	A22H15A	Back up washer
14	A22H16	Head cap
15	A22H18	Capscrew, 1/4" x 1"
16	A22H17	Wiper seal, 1-1/2" ID
	A22H19B	Packing kit containing:
		1 A22H06 2 A22H15 2 A22H07
		1 A22H15A 2 A22H08 1 A22H17
		1 A22H10A

HYDRAULIC CYLINDER
2-1/2" BORE X 16" STROKE
(OPTIONAL)
HIGH PRESSURE

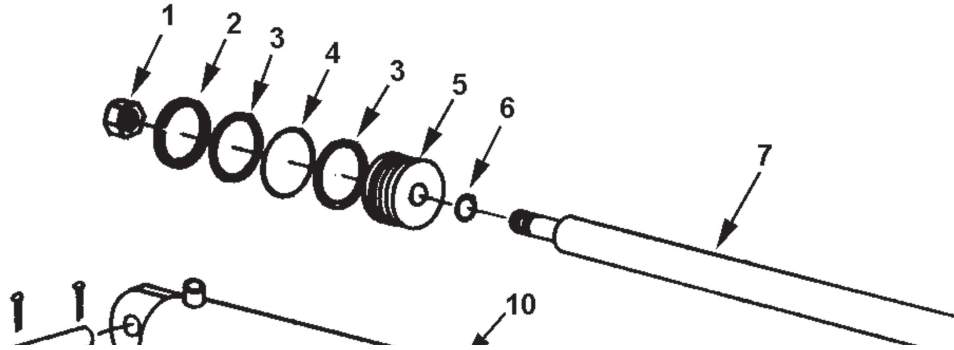

KEY NO.	QUANTITY	PART NO.	DESCRIPTION
1	1	A22H12-P	Butt and tube assembly
2	1	A-2043-8	Lock nut
3	1	PMAP-K-41	Piston ring
4	2	PMAP-O-41	O-ring
5	1	PMAP-W-41	Bu-washer
6	1	PMAP-O-15	O-ring
7	1	P4-1510	Piston
8	1	A22H11-P	Piston rod
9	1	GIC-2470	Gland
10	1	PMAP-O-27	O-ring
11	1	PMAP-W-27	Bu-washer
12	1	TSR-350	Snap ring
13	1	PMAP-CM-27	Wiper
		PMCK-5500D	Seal kit

HYDRAULIC CYLINDER
2-1/2" BORE X 16" STROKE
(OPTIONAL)
HIGH PRESSURE

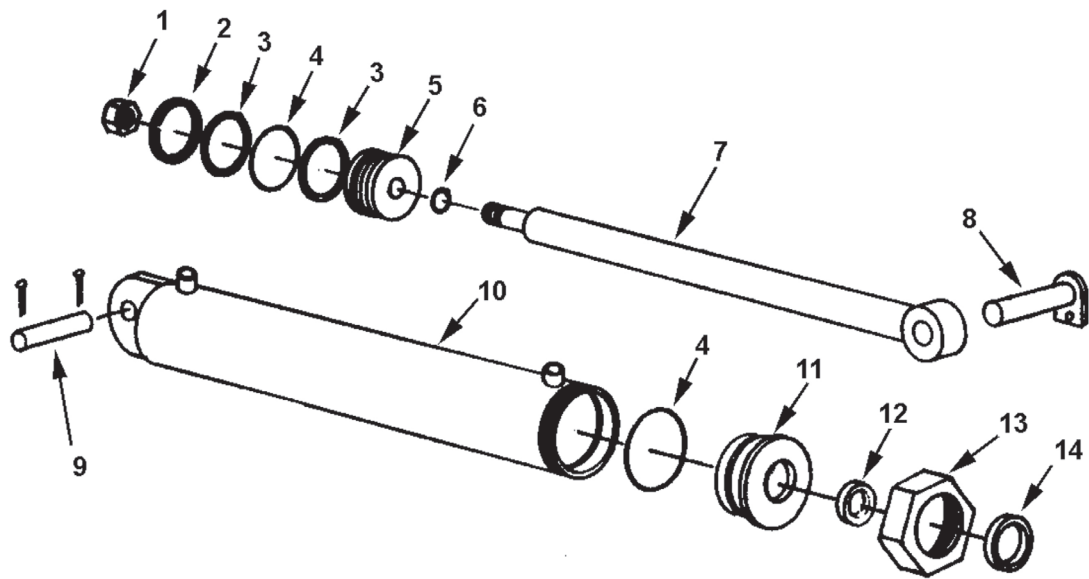

25-cyl-high-ill

MODEL A2516H1

KEY NO.	PART NO.	DESCRIPTION
1	A22H05	Piston nut, 3/4" NF
2	A22H20	Cast iron piston ring, 2-1/2" OD
3	A22H21	Piston back up washer, 2-1/2" OD
4	A22H22	O-ring seal, 2-1/2" OD
5	A22H23	Piston, 2-1/2"
6	A22H10	Piston gasket
7	A22H24	Shaft, 1-1/4" dia.
8	A3318	Pin, 1" x 5-5/8" tab head
9	A2508	Capscrew, 1/2" NC x 1" w/ LW
		Pin, 1" x 3-1/4"
10	A22H25	Cotter pin, 3/16" x 1-1/2"
11	A22H26	Barrel assembly, 2-1/2" ID
12	A22H27	Head gland
	A22H27A	O-ring
		Back up washer
13	A22H28	Head cap
14	A22H29	Wiper seal
	A22H30	Packet kit containing:
		1 A22H20 2 A22H27 2 A22H21
		1 A22H29 2 A22H22 1 A22H27A
		1 A22H10

Limited Warranty Statement

Ashland Industries Inc. warrants each new product to be free from defects in material and workmanship. This warranty is applicable only for the normal service life expectancy of the product or components, not to exceed **six consecutive months** from the date of delivery of the new Ashland Industries product to the purchaser, or the date the product is first put into service via a rental agreement or other means, whichever occurs first.

The major components of swivel hitches used on Industrial series scrapers are warranted for three consecutive months from the date of delivery of the new Ashland Industries product to the purchaser, or the date the product is first put into service via a rental agreement or other means, whichever occurs first, except those components described below.

Genuine Ashland Industries Inc. replacement parts and components will be warranted for 30 days from date of purchase, or the remainder of the original equipment warranty period, whichever is longer.

Under no circumstances will it cover any merchandise or components thereof, which in the opinion of the company, has been subjected to misuse, unauthorized modification, alterations, an accident or if repairs have been made with parts other than those obtained through Ashland Industries Inc.

Ashland Industries Inc. in no way warrants Tires since their respective manufacturer warrants these items separately. Please call Ashland Industries Inc. to receive phone numbers of tire suppliers.

Ashland Industries Inc. in no way warrants wearable items such as cutting edges, front dolly wheel balls, socket halves, rollers, bushings, yoke hitch pins, hitch bushings, etc..

Our obligation under this warranty shall be limited to repairing or replacing, free of charge to the original purchaser, any part that, in our judgement, shall show evidence of such defect, provided further that such part shall be returned within 30 days from the date of failure to Ashland Industries Inc. routed through the dealer and distributor from whom the purchase was made, transportation charges prepaid. Upon warranty approval proper credits will be reimbursed for transportation.

This warranty shall not be interpreted to render Ashland Industries Inc. liable for injury or damages of any kind or nature to person or property. This warranty does not extend to the loss revenue, extra labor cost associated with downtime, substitute machinery, rental or for any other reason.

Except as set forth above, Ashland Industries Inc. shall have no obligation or liability of any kind on account of any of its equipment and shall not be liable for special or consequential damages. Ashland Industries Inc. make no other warranty, expressed or implied, and, specifically, Ashland Industries Inc. disclaims any implied warrant or merchantability or fitness for a particular purpose. Some states or provinces do not permit limitations or exclusions of implied warranties or incidental or consequential damages, so the limitations or exclusion in this warranty may not apply.

This warranty is subject to any existing conditions of supply which may direct affect our ability to obtain materials or manufacture replacement parts.

Ashland Industries Inc. reserves the right to make improvements in design or changes in specifications at any time, without incurring any obligation to owners of units previously sold

No one is authorized to alter, Modify or enlarge this warranty nor the exclusion, limitations and reservations.

Ashland Industries Inc.
Warranty Department