

# Ashland

## EARTHMOVERS



---

# Model 70

# PARTS MANUAL

---

Version 3-2007

Ashland Industries Inc.  
1115 Rail Drive  
P.O. Box 717  
Ashland, WI. 54806  
Ph: 877-634-4622 Toll Free  
Ph: 715-682-4622  
Fx: 715-682-9717  
[www.ashlandind.com](http://www.ashlandind.com)

MEMBER



CONSTRUCTION INDUSTRY  
MANUFACTURERS ASSOCIATION





## Model 70 Scraper

### HOW TO ORDER PARTS:

#### **IMPORTANT**

Parts must be ordered through your local authorized ASHLAND dealer.

Be sure to state MODEL and SERIAL NUMBER of your machine, PART NUMBER, DESCRIPTION and QUANTITY needed.

Unless this is done, we cannot provide prompt service or assure shipment of the correct parts.



Ashland Industries weldable replacement parts are available to rebuild, modify or update your scraper to current factory specifications.

### **INDEX**

Page 3.	Operator and Maintenance Instructions
Page 4.	Safety Guidelines
Page 5.	Illustration - Assembly
Page 6-7.	Assembly Instructions
Page 8.	Frame Assembly
Page 9.	Pole and Axle Assembly
Page 10.	Actuating Assembly
Page 11.	Bucket and Apron Assembly
Page 12.	Wheel, Hub and Spindle Assembly
Page 13.	Hydraulic Cylinder (5" x 16")
Page 14.	How to Operate the W7B-20DC Rim
Page 15.	Warranty Statement

## **OPERATOR AND MAINTENANCE INSTRUCTIONS**

The scraper is a durable piece of equipment and with proper care will yield many years of trouble free operation. The scraper requires a power source with one 4-way (double acting) hydraulic control valve.

After scraper has been assembled, it should be greased at all points where grease fittings are provided. Connect hydraulic hoses to tractor and operate the scraper to maximum raise and drop several times to force any air from the hydraulic lines and cylinders. Check the oil level in the tractor hydraulic system and add to maintain the proper level.

When the scraper is placed into operation, the operator will have to "feel out" the amount of depth of cut to obtain maximum loading efficiency. This is usually accomplished by taking a lesser and more uniform cut. However, some soil conditions such as loose sand may require a "pumping action" obtained by taking successive deep cuts and lifting out of cut as the tractor begins to lose power or traction.

1. After 10 hours work, all bolts should be checked and tightened if necessary.
2. Every 10 hours all grease fittings should be lubricated.
3. After 50 hours work, all bolts should be rechecked and tightened if necessary. Check wheel bearings and adjust if necessary.
4. After 300 hours work, clean and repack wheel bearings and replace, if necessary, cutting edges, worn pins, etc.



## SAFETY SIGNAL WORDS

Note the use of the signal words DANGER, WARNING and CAUTION with the safety messages. The appropriate signal word for each has been selected using the following guidelines:



**DANGER:** Indicates an imminently hazardous situation that, if not avoided, will result in death or serious injury. This signal word is to be limited to the most extreme situations typically for machine components which, for functional purposes, cannot be guarded.



**WARNING:** Indicates a potentially hazardous situation that, if not avoided, could result in death or serious injury, and includes hazards that are exposed when guards are removed. It may also be used to alert against unsafe practices.



**CAUTION:** Indicates a potentially hazardous situation that, if not avoided, may result in minor or moderate injury. It may also be used to alert against unsafe practices.



## GENERAL SAFETY GUIDELINES

Safety of the operator is one of the main concerns in designing and developing a new piece of equipment. Designers and manufacturers build in as many safety features as possible. However, every year many accidents occur which could have been avoided by a few seconds of thought and a more careful approach to handling equipment. You, the operator, can avoid many accidents by observing the following precautions in this section. To avoid personal injury, study the following precautions and insist those working with you, or for you, follow them.

Replace any CAUTION, WARNING, DANGER or instruction safety decal that is not readable or is missing. Location of such decals is indicated in this booklet.

Do not attempt to operate this equipment under the influence of drugs or alcohol.

Review the safety instructions with all users annually.

This equipment is dangerous to children and persons unfamiliar with its operation. The operator should be a responsible adult familiar with farm machinery and trained in this equipment's operations. **Do not allow persons to operate or assemble this unit until they have read this manual and have developed a thorough understanding of the safety precautions and of how it works.**

To prevent injury or death, use a tractor equipped with a Roll Over Protective System (ROPS). Do not paint over, remove or deface any safety signs or warning decals on your equipment. Observe all safety signs and practice the instructions on them.

Never exceed the limits of a piece of machinery. If its ability to do a job, or to do so safely, is in question - **DON'T TRY IT.**

# ILLUSTRATION - ASSEMBLY

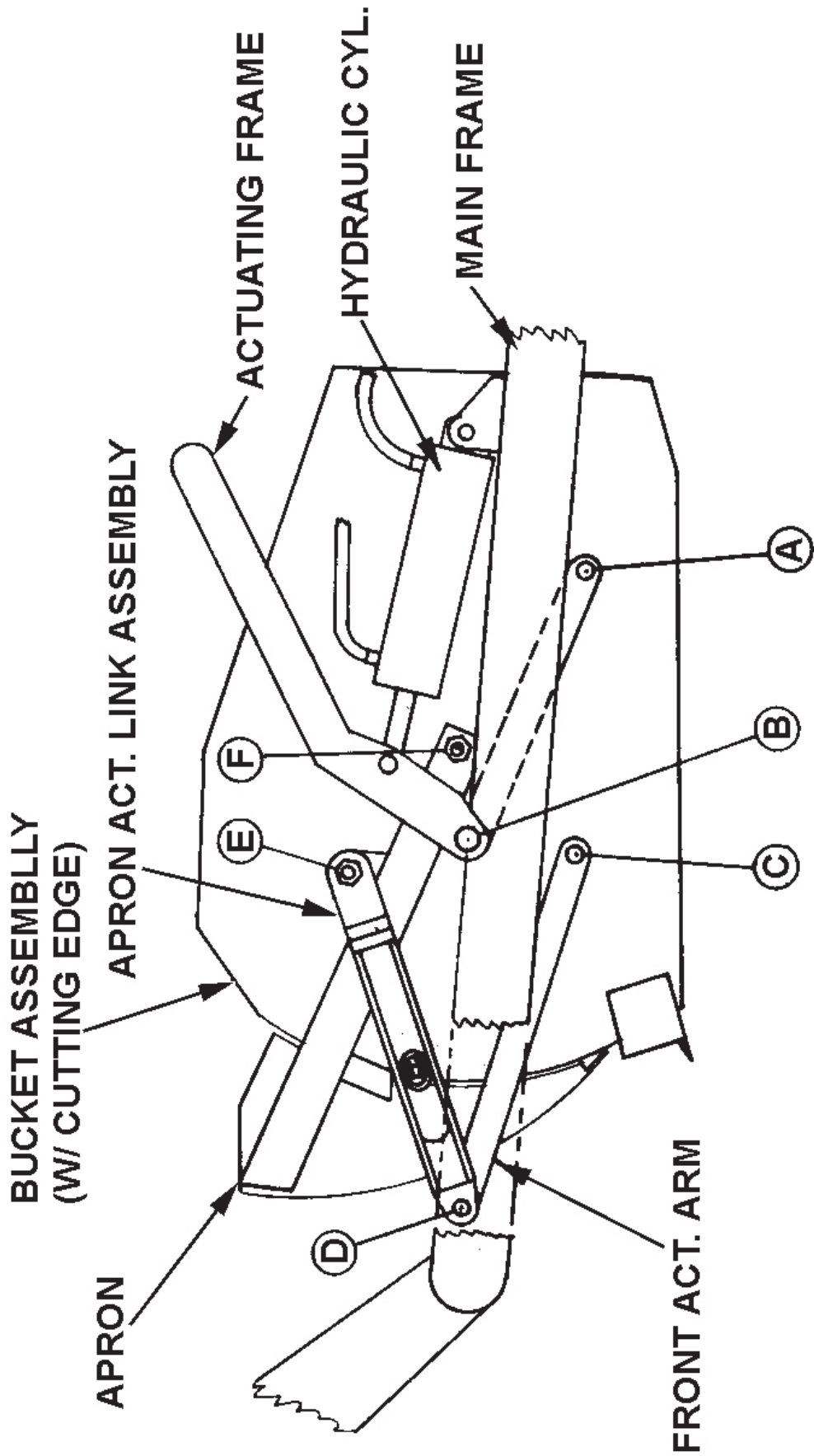

## **ASSEMBLY INSTRUCTIONS FOR MODEL 70 SCRAPER (Refer to illustration on previous page)**

1. A suitable hoist or lift should be available for assembly.
2. Install rear spindles to frame in lowest possible setting to obtain the maximum spreading depth between cutting edge and ground. If less depth of spread is desired, select a lower setting or reverse the spindle bottom-to-top.
3. Pack wheel bearings with grease and install hubs to rear spindles and to front axle assembly on model 70D scrapers.
4. Raise the actuating frame over bucket and lower into place so that the holes in the arms of the actuating frame align with the rear hole on each side of the bucket. (Point A). Insert 1 1/2" x 2 3/4" pins (with tab type head) from the inside of the bucket. Secure with 5/8" x 1 1/2" NF bolt through bucket side with nut and lockwasher to the outside.
5. Install the actuating arm bars to the front holes in the bucket. (Point C) Insert 1 1/2" x 2 3/4" pins (with tab head) from the inside of the bucket. Secure with 5/8" x 1 1/2" NF bolt through bucket side with lock nut on the outside.
6. Connect a short chain from the cutting edge to the cross pipe of the actuating frame, then raise the bucket and actuating frame assembly over the main frame and lower into place so that the front of the actuating frame can be connected to the 1 3/4" bushing on each side of the frame. (Point B) Secure with 5/8" x 1-1/4" NC capscrews and lockwashers.
7. Lift the front end of the actuating arms and connect to the brackets on the front frame cross-member using 1 1/2" x 4 1/2" pins. (Point D) Do not insert the pins completely.
8. Raise the apron over the scraper and lower into place so the hole in the end of the arms aligns with the hole in each side of the bucket walls (Point F). Attach with 1-5/8" to 1-1/4" shoulder pins (with grease hole in hex head). Secure with 1-1/4" NF thick nut.
9. Install hydraulic cylinders to main frame and actuating frame with rod end to actuating frame. Be sure the grease hole in the rod end is facing up. Use 1-1/8" x 3 1/4" pin at the base of the cylinder. Secure with 3/16" x 1 1/2" cotter pins. Use 1-1/4" x 6" pin at the rod end of the cylinder. Secure with 1/2" x 1" NC capscrew and lockwasher.
10. Install 1/2" x 90° swivel adapters into front and rear ports on each cylinder. Tighten so that the hose fitting faces the rear.

11. Connect a ½" x 18" hose from the rear port of each cylinder to one of the pipe lines in the rear cross frame. Be sure both hoses from the rear ports are connected to the same pipe line.
12. Connect a ½" x 38" hose from the front port of each cylinder to the remaining pipe line on the rear cross-member of the frame.
13. Install the apron actuating links (linkage with built-in spring) to the bracket on each apron arm (Point E), using the 1-5/8" to 1-1/4" shoulder pins (with grease hole in threaded end). Secure with 1-1/4" NF lock nut (thin). Be certain the open end of the tube containing spring is downward.
14. Connect the opposite end of the apron actuating links, referred to in step 10, to the bracket on the front frame cross-member, referred to in step 9, adjacent to the actuating arms connected from the bucket (Point D). Insert the pins the remainder of the way and secure tab to bracket with ½" NC x 1-1/4" capscrew and lockwasher
15. Raise the rear of frame and install wheels to hubs. Also install wheels to front axle assembly.  
  
(Steps 14 and 15 refer to model 70D scrapers only)
16. Raise the front of the frame and remove the two 5/8" x 4" bolts which hold the cast socket halves inside the gooseneck post. Remove the socket halves.
17. Roll the pole and axle assembly directly under the gooseneck and place the cast socket halves around the ball swivel on the axle. Lower the frame into place so that the socket halves seat into the gooseneck. (If necessary, clamp halves together with C-clamp while lowering gooseneck.) Replace the two 5/8" x 4" bolts and tighten securely. Install a long shank grease fitting into hole provided.
18. Install all the grease fittings and grease liberally.
19. If possible, place assembled scraper on level floor or pavement and measure the distance from the cutting edge to floor, on both left and right sides, and then adjust rear spindles to obtain equal distance on both sides.

ASHLAND INDUSTRIES, INC.

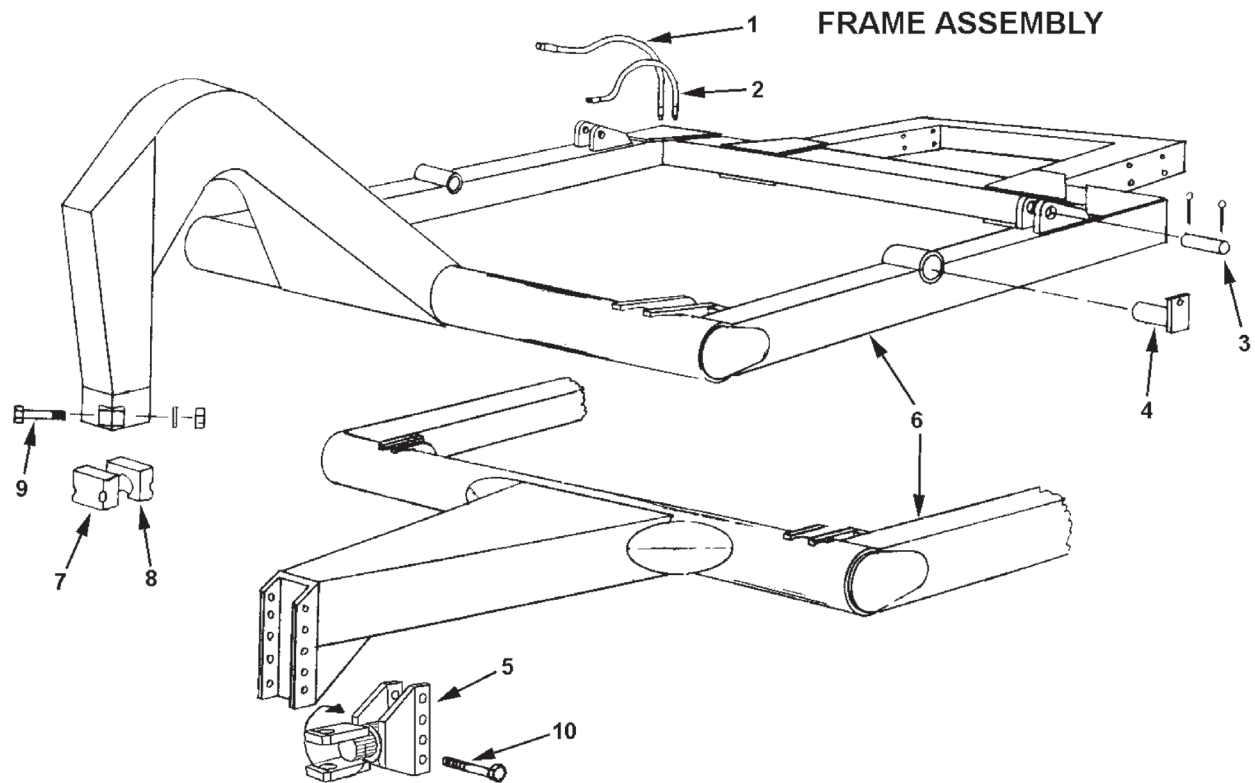

70-frame-ill

<b>KEY NO.</b>	<b>PART NO.</b>	<b>DESCRIPTION</b>
1	A400H01	Hydraulic hose, 1/2" 38"
2	A60H01A	Hydraulic hose, 1/2" x 18"
	A400H02	Swivel adapter, 1/2" x 90°
3	A45003	Pin, 1-1/8" x 3-1/4" w/ 3/16" x 1-1/2" cotter
4	A40016A	Pin, 1-3/4" x 6-1/8" w/ lock type head
5	A8033	Swivel hitch
6	A6002C	Frame - 4 wheel
	A6003C	Frame - 2 wheel
7	A40005	Cast socket half, front, w/ zerk hole
	A2206	Zerk, w/ long straight shank
8	A40004	Cast socket half, rear
9		Bolt, 5/8" NC x 4" w/ nut & lockwasher
10		Bolt, 1-1/4" NF x 7" w/ lock nut



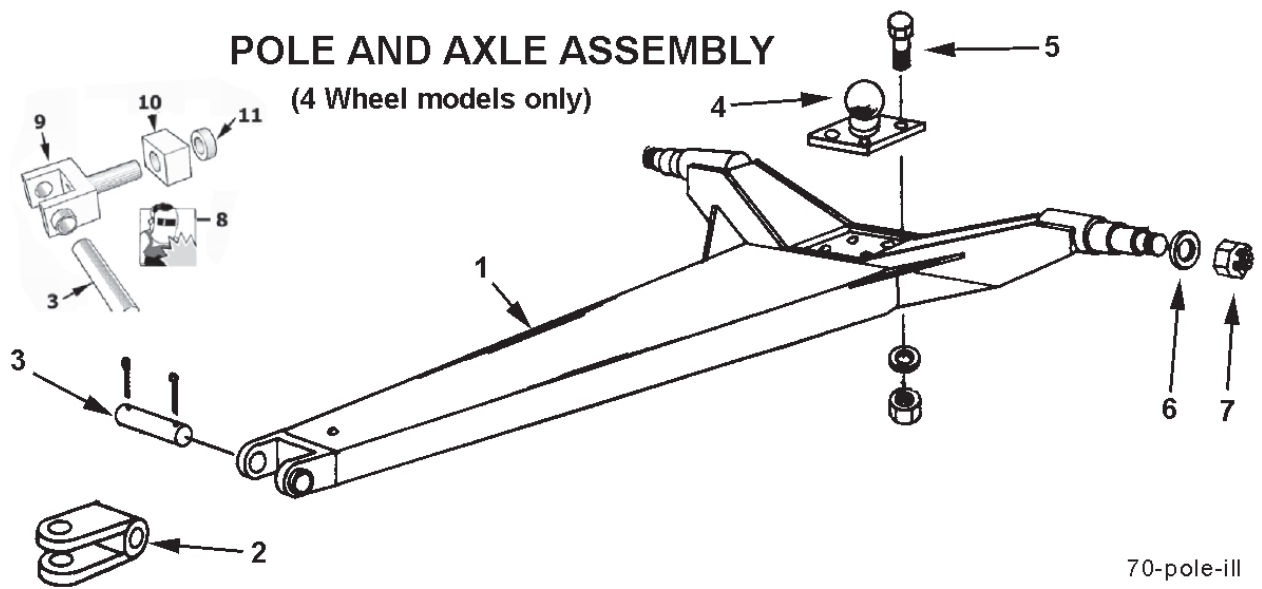

<b>KEY NO.</b>	<b>PART NO.</b>	<b>DESCRIPTION</b>
1	A40007D	Pole & Axle
2	A6013	Swivel hitch, double lip
	A6013A	Swivel hitch, single lip
3	A6014	Pin, 1-1/4" x 6-3/4", w/ 5/16" NC x 2-1/2" bolt
4	A40006	Ball swivel
5		Bolt, 3/4" x 2-1/2" w/ nut & lockwasher
6	A2239	Washer, special 7/8" flat
7	AFN-00005	Nut, 7/8" castellated
8	A6012	Swivel Hitch Rebuild Kit, includes items 3, 9, 10, 11.
9	A021468	Hitch: Swivel Yoke
10	A051368	Hitch: Swivel Block
11	A051368-2	Hitch: Retaining Collar

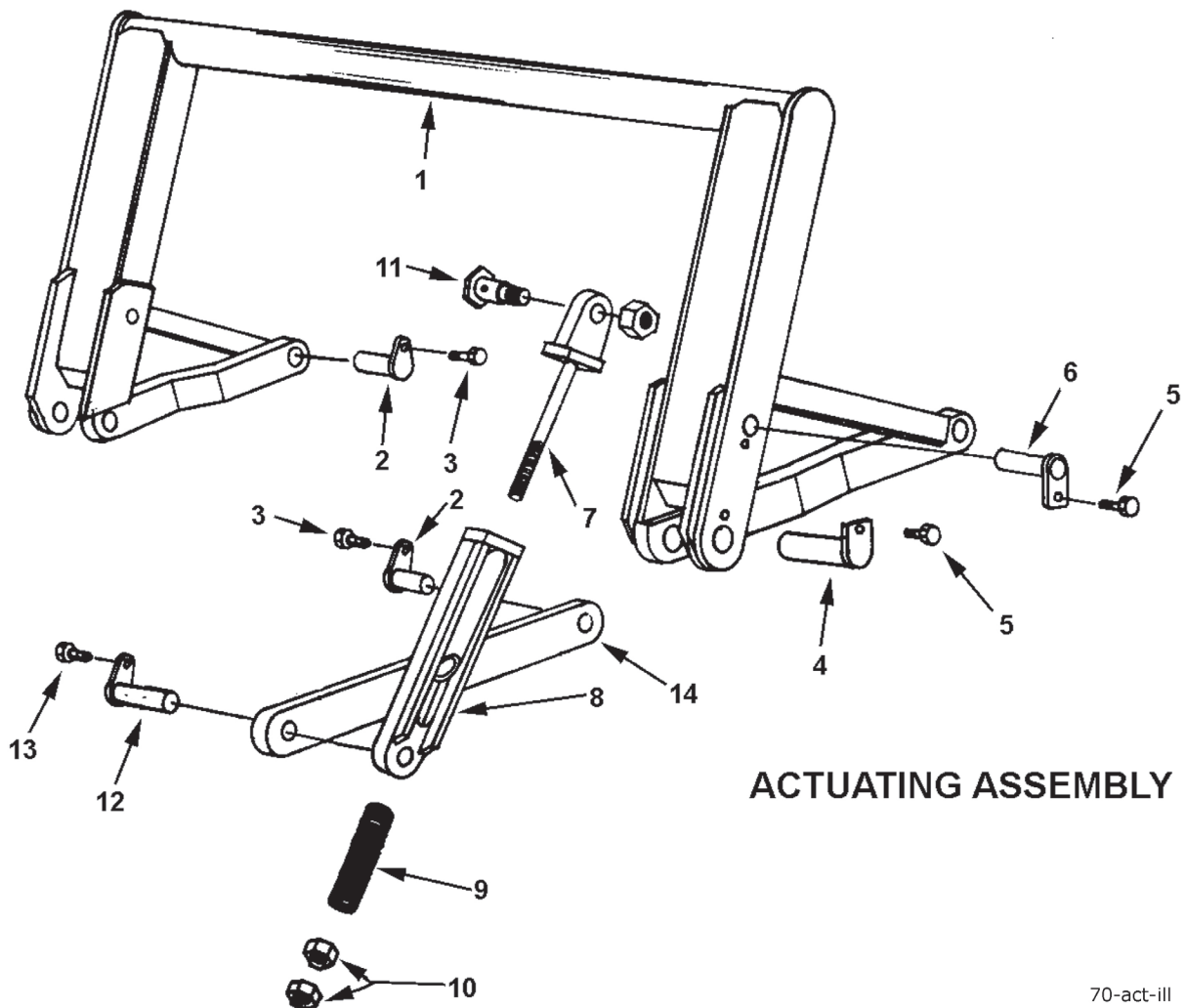

**ACTUATING ASSEMBLY**

70-act-iii

<b>KEY NO.</b>	<b>PART NO.</b>	<b>DESCRIPTION</b>
1	A7004	Actuating frame
2	A8005	Pin, 1-1/2" x 2-3/4" w/ tab head
3		Bolt, 5/8" x 1-1/2" NF w/ nut & lockwasher
4	A40016A	Pin, 1-3/4" x 6-5/8" w/ tab head
5		Capscrew, 5/8" x 1-1/4" NC w/ lockwasher
6	A7010	Pin, 1-1/4" x 6" w/ tab head
7	A6015	Actuating link (upper half)
8	A6016	Actuating link (lower half)
9	A6018	Compression Spring, 1" ID x 2" OD x 10" long
10		Nut, 1" NF
11	A6019	Shoulder pin, 1-5/8" x 1-1/4" w/ zerk in thread end
		Nut, 1-1/4" NF, lock type
12	A6020	Pin, 1-1/2" x 4-1/2" w/ locking head w/ zerk
13		Capscrew, 1/2" NC x 1-1/4" w/ lockwasher
14	A7006	Actuating arm

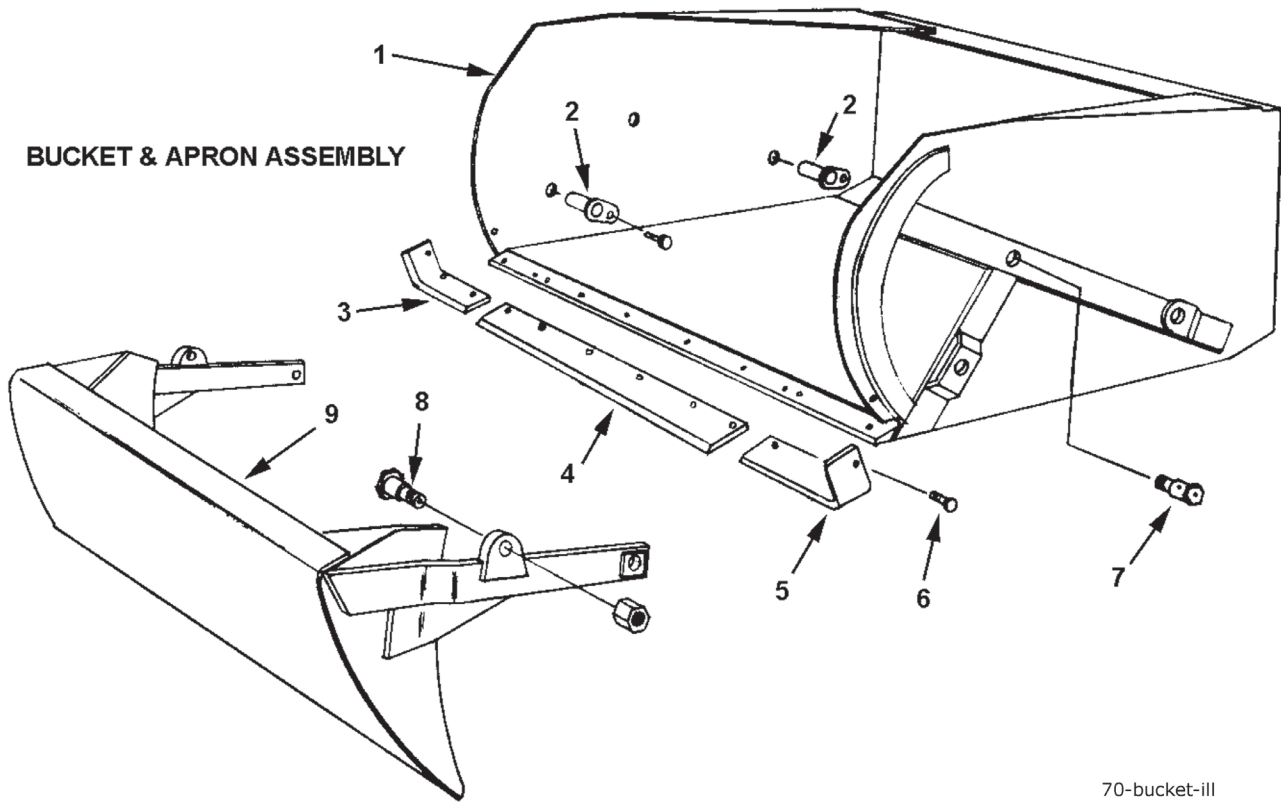

<b>KEY NO.</b>	<b>PART NO.</b>	<b>DESCRIPTION</b>
1	A7008	Bucket
2	A8005	Pin, 1-1/2" x 2-3/4" w/ locking head
3	A2225	Bolt, 5/8" x 1-1/2" NF w/ nut & lockwasher
4	A8030	Right cutting edge
5	A2222	Center cutting edge, 8" x 54"
6		Left cutting edge
7		Plow bolt, 1/2" x 1-3/4" w/ nut (6 req'd)
8		Plow bolt, 5/8" x 2" w/ nut (6 req'd)
9	A6010	Shoulder pin, 1-5/8" to 1-1/4" w/ zerk in head
		Nut, 1-1/4" NF, lock type
	A6019	Shoulder pin, 1-5/8" to 1-1/4" w/ zerk in thread end
		Nut, 1-1/4" NF, lock type
	A7009	Apron

# WHEEL, HUB & SPINDLE

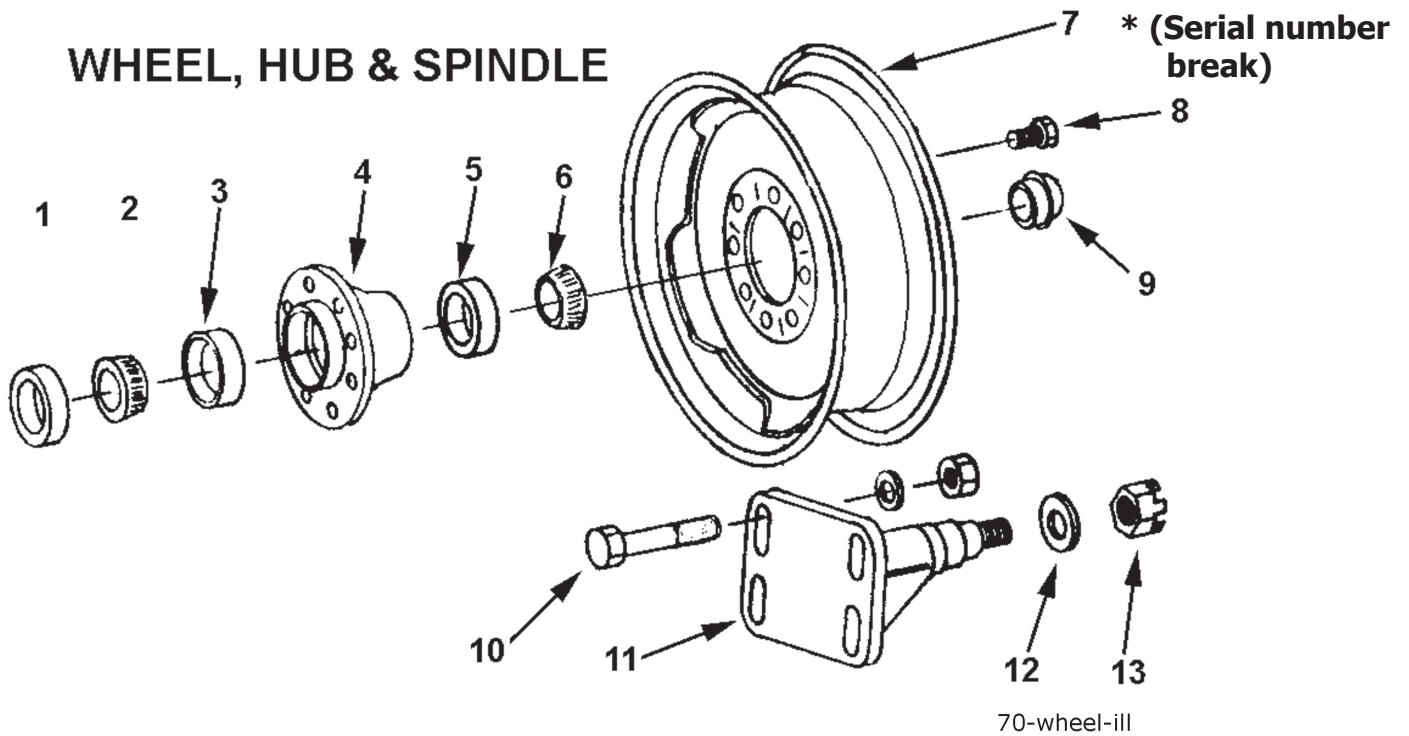

KEY NO.	PART NO.	DESCRIPTION
1	A4512	Grease seal ( National 415082 )
2	A4513	Bearing cone (inner) ( Timken 3784 )
3	A4514	Bearing cup (inner) ( Timken 3720 )
4	A4515	Hub (less bearings)
5	A2233	Bearing cup (outer) ( Timken 14276 )
6	A4516	Bearing cone (outer) ( Timken 14137A )
7	*A4521A	Wheel, 20" D.C. (up to sn 20667) Dec 2002
	*A125047	Wheel, 22.5" x 8.25 (sn 20668 & up) Jan 2003
	A6022	Wheel, 16" x 11" DC (optional)
8	A4519	Wheel bolt, 9/16" NF
9	A2235	Hub cap
10	AFB-00004	Bolt, 3/4" x 6" w/ flat washer & nut
11	A4520	Spindle weldment
12	A2239	Washer, special, 7/8" flat
13	AFN-00005	Nut, 7/8" NF castellated

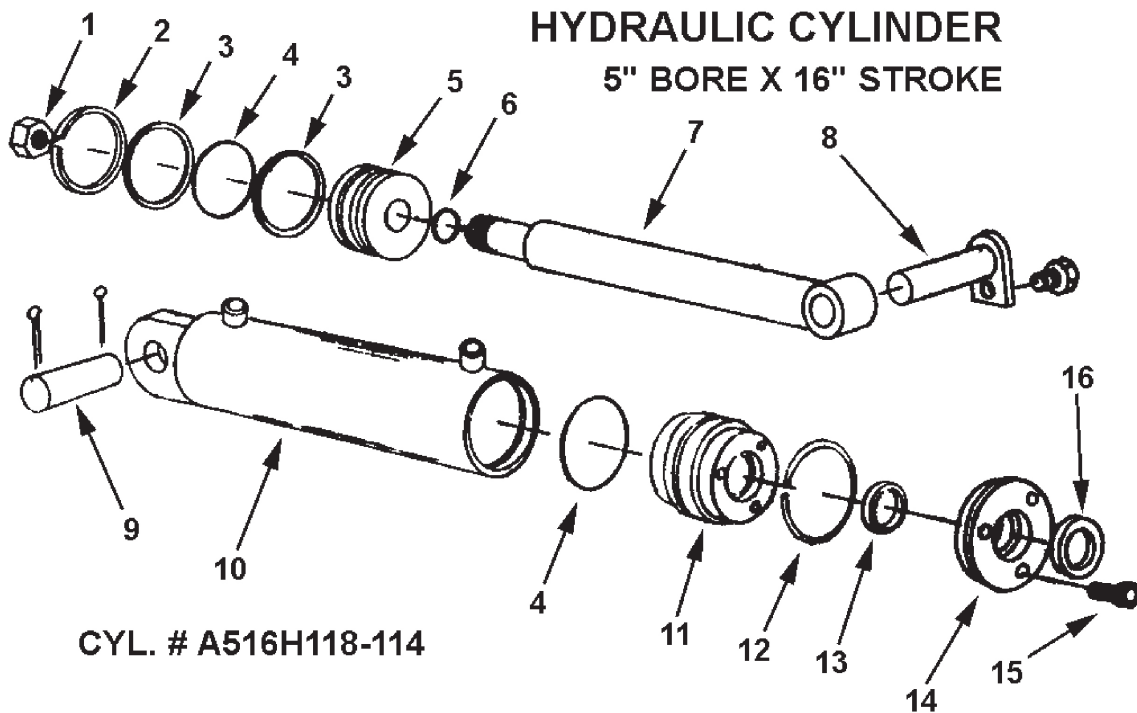

70-hyd cyl-ill

<b>KEY NO.</b>	<b>PART NO.</b>	<b>DESCRIPTION</b>
1	A400H17	Piston nut, 1-1/4" NF
2	A400H04	Cast iron ring, 5" OD
3	A400H05	Backup washer, 5" OD
4	A400H06	O-ring, 5" Odx 1/4"
5	A400H07	Piston, 5" dia.
6	A22H27	Piston gasket, 1-1/4" ID
7	A70H10	Shaft, 2" dia.
8	A7010	Pin, 1-1/4" x 6"
9	A45003	Capscrew, 1/2" x 1" NC w/ lockwasher Pin, 1-1/8" x 3-1/4"
10	A400H09	Cotter pin, 3/16" x 1-1/2" Barrel Assembly
11	A400H10	Head gland
12	A400H11	Retainer ring
13	A400H12	O-ring, 2"
14	A400H12A	Backup washer
14	A400H13	Head cap
15	A22H18	Capscrew, 1/4" NC x 1"
16	A400H14	Wiper seal
	A400H15B	Packing kit containing:
		1 - A400H04    1 - A400H11    2 - A400H05
		1 - A400H14    2 - A400H06    2 - A400H12
		1 - A22H27    1 - A400H12A



# HOW TO OPERATE THE W7B-20DC RIM

**Note:** This rim has been developed for 20" used truck tires up to and including 9.00-20 ten ply. However, many users have found it possible to mount 10.00-20 twelve ply tires. The following procedures should be followed:

**Tools and Materials Required:** One Set Firestone Truck Tire Tools (48-A-200)  
One Pair Vise-Grip Pliers  
Lubricant (Avoid use of compound that contains water . . . or a solvent injurious to rubber — see your rim distributor)

## MOUNTING:



1. Remove flap inasmuch as it is not required on the drop center rim mounting and it prevents mounting the tire. Check to see tube is in casing and inflated sufficiently to prevent sag below tire beads.



2. Place rim on floor with valve hole side up. Place tire over rim with valve stem pointing upwards. Force lower bead into well of rim as far as possible.



3. Lubricate last section of lower bead to facilitate mounting.



4. Using straight end of tool (with stop resting on rim flange) take small bites to work remaining section of lower bead onto rim.



5. Stand tire up with valve and valve hole at top of rim. Insert valve into valve hole.



6. To get top bead in place stand on tire and force bead down as far as possible and clamp vice grip pliers on the flange. (snub side toward tire). Using spoon end of tire iron with lug side towards rim, work progressively around bead using small bites until bead slips over flange onto rim base. In order to mount last 6" of bead it usually is necessary to insert second tire iron and lubricate the last bead portion.

## DEMOUNTING:



1. Remove valve core to deflate and loosen tire from bead seat of rim on both sides. Lubricate upper bead of tire thoroughly. With stops toward rim, insert spoon ends of both tools about 10 inches apart. While standing on tire to hold bead in well, pull one tool back toward center of rim.



2. Hold first tool in position with one foot and pull second tool toward center of rim. Progressively work top bead off rim, taking additional bites if necessary.



3. Stand tire and tube in vertical position with valve at top of assembly and remove valve from valve hole. Then place valve at bottom of assembly and pull out upper portion of tube so it will not interfere with demounting the second bead. Lubricate second bead. At top of assembly insert straight end of tool between bead and back flange of rim at about a 45° angle. Turn tool so it is perpendicular to rim. Pry second bead off.

**ELECTRIC WHEEL COMPANY-QUINCY, ILL.**

Division of the Firestone Tire & Rubber Company

302-0 COPYRIGHT 1958, THE FIRESTONE TIRE & RUBBER CO.

61-tire-ill

# Limited Warranty Statement

Ashland Industries Inc. warrants each new product to be free from defects in material and workmanship. This warranty is applicable only for the normal service life expectancy of the product or components, not to exceed **six consecutive months** from the date of delivery of the new Ashland Industries product to the purchaser, or the date the product is first put into service via a rental agreement or other means, whichever occurs first.

The major components of swivel hitches used on Industrial series scrapers are warranted for three consecutive months from the date of delivery of the new Ashland Industries product to the purchaser, or the date the product is first put into service via a rental agreement or other means, whichever occurs first, except those components described below.

Genuine Ashland Industries Inc. replacement parts and components will be warranted for 30 days from date of purchase, or the remainder of the original equipment warranty period, whichever is longer.

Under no circumstances will it cover any merchandise or components thereof, which in the opinion of the company, has been subjected to misuse, unauthorized modification, alterations, an accident or if repairs have been made with parts other than those obtained through Ashland Industries Inc.

Ashland Industries Inc. in no way warrants Tires since their respective manufacturer warrants these items separately. Please call Ashland Industries Inc. to receive phone numbers of tire suppliers.

Ashland Industries Inc. in no way warrants wearable items such as cutting edges, front dolly wheel balls, socket halves, rollers, bushings, yoke hitch pins, hitch bushings, etc..

Our obligation under this warranty shall be limited to repairing or replacing, free of charge to the original purchaser, any part that, in our judgement, shall show evidence of such defect, provided further that such part shall be returned within 30 days from the date of failure to Ashland Industries Inc. routed through the dealer and distributor from whom the purchase was made, transportation charges prepaid. Upon warranty approval proper credits will be reimbursed for transportation.

This warranty shall not be interpreted to render Ashland Industries Inc. liable for injury or damages of any kind or nature to person or property. This warranty does not extend to the loss revenue, extra labor cost associated with downtime, substitute machinery, rental or for any other reason.

Except as set forth above, Ashland Industries Inc. shall have no obligation or liability of any kind on account of any of its equipment and shall not be liable for special or consequential damages. Ashland Industries Inc. make no other warranty, expressed or implied, and, specifically, Ashland Industries Inc. disclaims any implied warrant or merchantability or fitness for a particular purpose. Some states or provinces do not permit limitations or exclusions of implied warranties or incidental or consequential damages, so the limitations or exclusion in this warranty may not apply.

This warranty is subject to any existing conditions of supply which may direct affect our ability to obtain materials or manufacture replacement parts.

Ashland Industries Inc. reserves the right to make improvements in design or changes in specifications at any time, without incurring any obligation to owners of units previously sold

No one is authorized to alter, Modify or enlarge this warranty nor the exclusion, limitations and reservations.

Ashland Industries Inc.  
Warranty Department