

MODEL 80 SCRAPER

HOW TO ORDER PARTS:

Be sure to state MODEL and SERIAL NO. of machine, PARTS NO., DESCRIPTION, and QUANTITY wanted.

Unless this is done, we cannot provide prompt service or assure shipment of the correct parts.

INDEX

PAGE NO.

- | | |
|------|---------------------------------------|
| 1. | Illustration - Assembly |
| 2-3. | Assembly Instructions |
| 4. | Operator and Maintenance Instructions |
| 5. | Frame Assembly |
| 6. | Pole and Axle Assembly |
| 7. | Actuating Assembly |
| 8. | Bucket and Apron Assembly |
| 9. | Wheel, Hub and Spindle Assembly |
| 10. | Hydraulic Cylinder (5" x 20") |
| 11. | How to Operate the W7B-20DC Rim |

ILLUSTRATION - ASSEMBLY

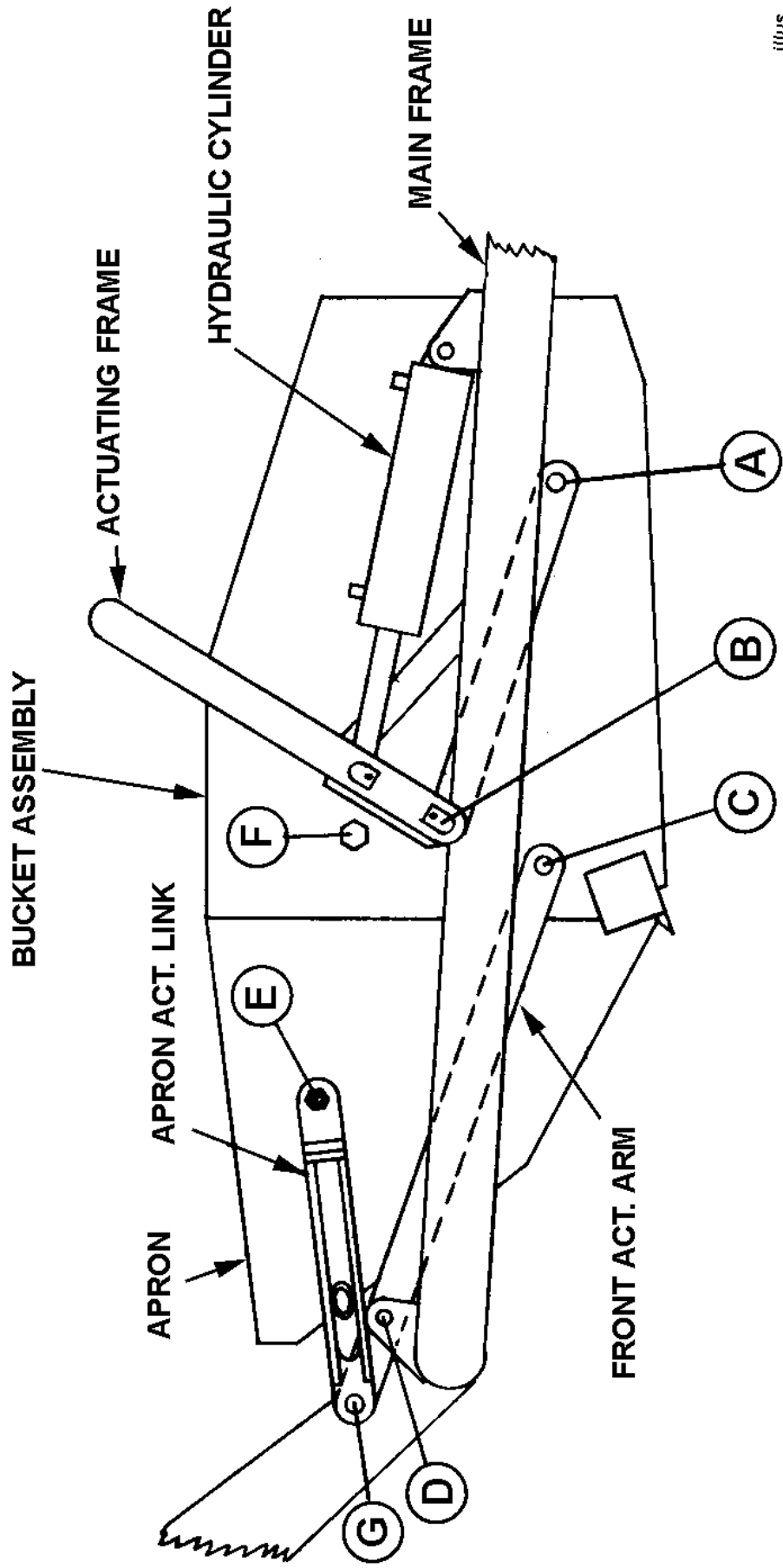

ASSEMBLY INSTRUCTIONS FOR MODEL 80 SCRAPER

(Refer to illustration on previous page)

1. A suitable hoist or lift should be available for assembly.
2. Pack wheel bearings with grease and install hubs to rear spindles and to front axle assembly on model 80D scrapers.
3. Install rear spindles to frame in lowest possible setting to obtain the maximum spreading depth between cutting edge and ground. If less depth of spread is desired, select a lower setting or reverse the spindle bottom-to-top.

(Steps 4 and 5 refer to model 80D scrapers only)

4. Raise the front of the frame and remove the two 5/8" x 3 1/2" bolts which hold the cast socket halves inside the gooseneck post. Remove the socket halves.
5. Roll the pole and axle assembly directly under the gooseneck and place the cast socket halves around the ball swivel on the axle. Lower the frame into place so that the socket halves seat into the gooseneck. (If necessary, clamp halves together with C-clamp while lowering gooseneck.) Replace the two 5/8" x 3 1/2" bolts and tighten securely. Install a long shank zerk into hole provided on front of gooseneck post.
6. Raise the actuating frame over bucket and lower into place so that the holes in the arms of the actuating frame align with the rear hole on each side of the bucket. (Point A). Insert 1 1/2" x 2 3/4" pins (with tab type head) from the inside of the bucket. Secure with 5/8" x 1 1/2" NF bolt through bucket side with locking nut to the outside.
7. Connect a short chain from the cutting edge to the cross pipe of the actuating frame, then raise the bucket and actuating frame assembly over the main frame and lower into place so that the front of the actuating frame can be connected to the 2" bushing on each side of the frame. (Point B) Secure with 2" x 7-1/8" pin and lock with 5/8" x 1" NC capscrew and lockwasher.
8. Install the actuating arm bars to the front holes in the bucket. (Point C) Insert 1 1/2" x 2 3/4" pins (with tab head) from the inside of the bucket. Secure with 5/8" x 1 1/2" NF bolt through bucket side with lock nut on the outside.
9. Lift the end of the front actuating arms and connect to the brackets on the front frame cross-member using 1 1/2" x 3 1/4" pins. (Point D) Secure with 1/4" x 2" cotter pins.
10. Install front apron gate and secure with 1 1/4" to 1 5/8" shoulder pin with zerk in head end. (Point F)
11. Install the two apron actuating links (open spring end toward front of scraper). Secure at Point E with 1 1/4" to 1-5/8" shoulder pin having zerk in threaded end. Secure at Point G with 1 1/2" flat washer and 1/4" x 2" cotter pin.
12. Install hydraulic cylinders to main frame and actuating frame with rod end to actuating frame. Be

sure the grease hole in the rod end is facing up. Use 1-1/8" x 3 1/4" pin at the base of the cylinder. Secure with 3/16" x 1 1/2" cotter pins. Use 1-1/8" x 7-3/8" pin at the rod end of the cylinder. Secure with 1/2" x 1" NC capscrew and lockwasher.

13. Install 1/2" x 90° swivel adapters into front and rear ports on each cylinder. Tighten so that the hose fitting faces toward the rear.
14. Connect a 1/2" x 18" hose from the rear port of each cylinder to one of the pipe lines in the rear cross frame. Be sure both hoses from the rear ports are connected to the same pipe.
15. Connect a 1/2" x 38" hose from the front port of each cylinder to the remaining pipe line on the rear cross frame.
16. Install all the grease fittings and grease liberally.
17. If possible, place assembled scraper on level floor or pavement and measure the distance from the cutting edge to floor, on both left and right sides, and then adjust rear spindles to obtain equal distance on both sides if necessary.

Addendum:

There are mating surfaces between the offset bar of the actuating frame and the side wall of the bucket where a rubbing action occurs. Likewise, there is a spot between the offset bar of the actuating frame and the inside of the main frame on left and right sides. Apply a film of grease at these locations.

The rubbing action at these locations is intentional to support the bucket while in operation.

ASHLAND INDUSTRIES, INC.

OPERATOR AND MAINTENANCE INSTRUCTIONS

The scraper is a durable piece of equipment and with proper care will yield many years of trouble free operation. The scraper requires a power source with one 4-way (double acting) hydraulic control valve.

After scraper has been assembled, it should be greased at all points where grease fittings are provided. Connect hydraulic hoses to tractor and operate the scraper to maximum raise and drop several times to force any air from the hydraulic lines and cylinders. Check the oil level in the tractor hydraulic system and add to maintain the proper level.

When the scraper is placed into operation, the operator will have to "feel out" the amount of depth of cut to obtain maximum loading efficiency. This is usually accomplished by taking a lesser and more uniform cut. However, some soil conditions such as loose sand may require a "pumping action" obtained by taking successive deep cuts and lifting out of cut as the tractor begins to lose power or traction.

1. After 10 hours work, all bolts should be checked and tightened if necessary.
2. Every 10 hours all grease fittings should be lubricated.
3. After 50 hours work, all bolts should be rechecked and tightened if necessary. Check wheel bearings and adjust if necessary.
4. After 300 hours work, clean and repack wheel bearings and replace, if necessary, cutting edges, worn pins, etc.

ASHLAND INDUSTRIES, INC.

FRAME ASSEMBLY

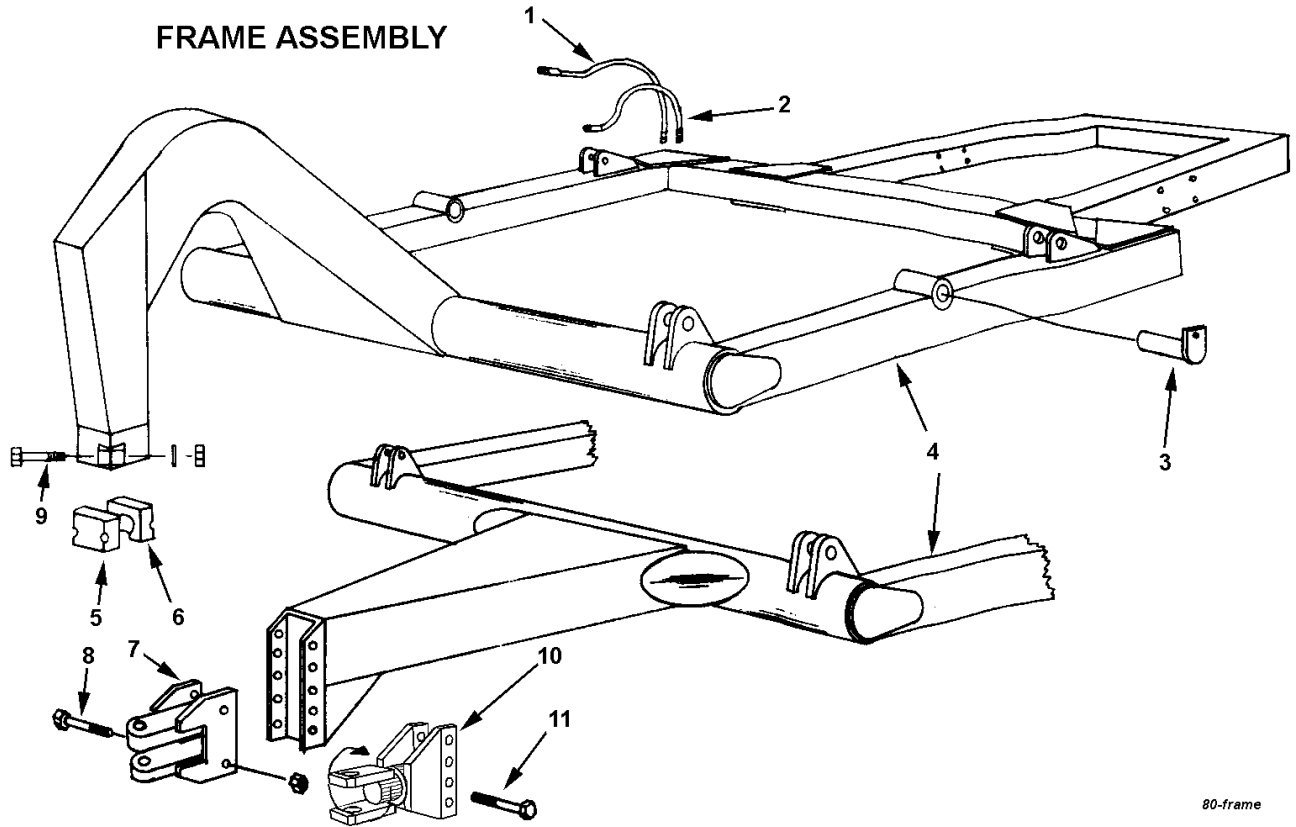

80-frame

<u>KEY NO.</u>	<u>PART NO.</u>	<u>DESCRIPTION</u>
1	A80H11	Hydraulic hose, 1/2" x 40"
2	A60H01A	Hydraulic hose, 1/2" x 18"
	A400H02	Swivel adapter, 1/2" x 90°
3	A8001	Pin, 2" x 7-1/8" w/ tab head
4	A8002	Frame - 4 wheel
	A8003	Frame - 2 wheel
5	A40005	Cast socket half, front, w/ zerk hole
6	A40004	Cast socket half, rear
7	A60004	Hitch, 2 wheel model
8		Bolt, 3/4" NC x 6" w/ nut & lockwasher
9		Bolt, 5/8" NC x 4" w/ nut & lockwasher
10	A8033	Swivel hitch
11		Bolt, 1-1/4" NF x 7" w/ locknut

POLE AND AXLE ASSEMBLY

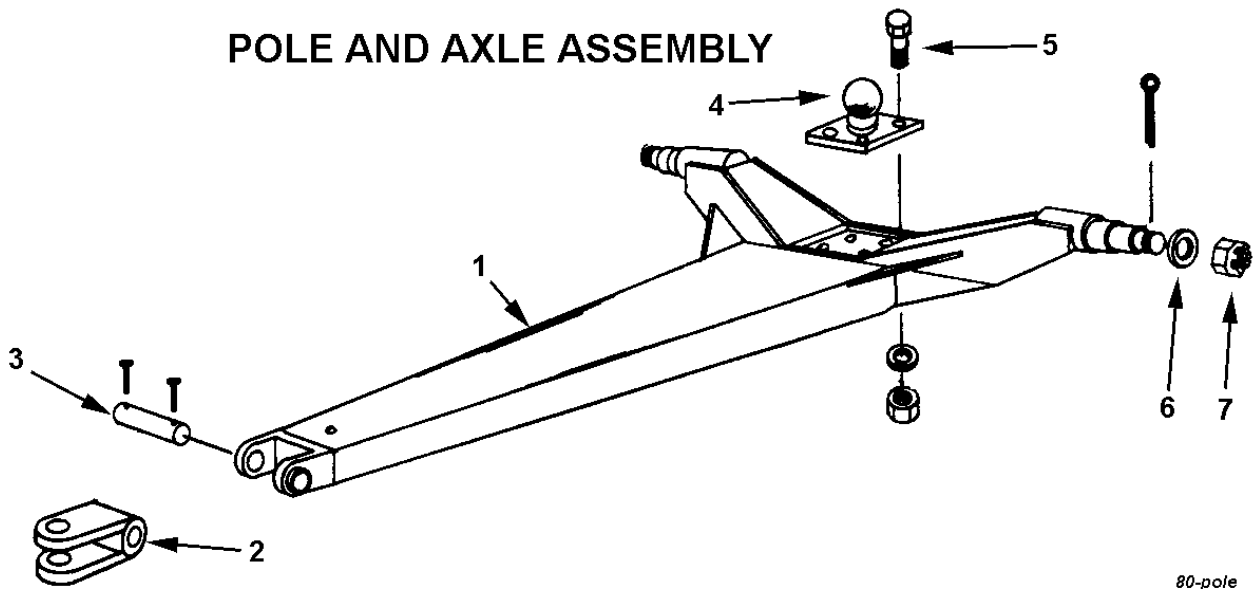

80-pole

(4-Wheel Models Only)

<u>KEY NO.</u>	<u>PART NO.</u>	<u>DESCRIPTION</u>
1	A8014	Pole and Axle
2	A6013	Swivel hitch clevis
3	A6014	Pin, 1-1/4" x 6-3/4" w/ 5/16" x 2-1/2" bolts
4	A40006	Ball swivel
5		Bolt, 3/4" x 2-1/2" w/ nut & lockwasher
6	A8027	Washer, special 1-1/4" flat
7		Nut, 1-1/4" NF castellated

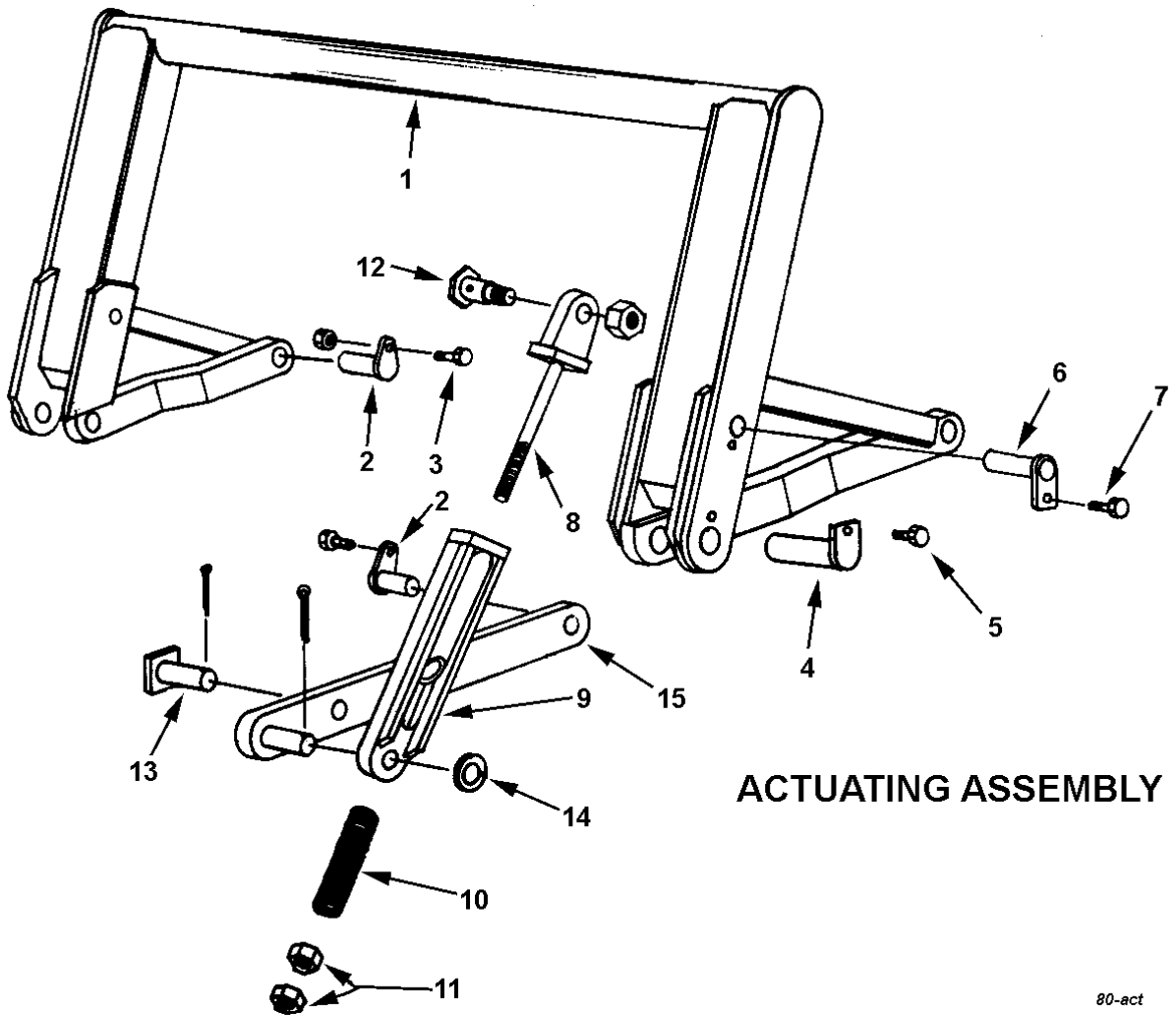

80-act

<u>KEY NO.</u>	<u>PART NO.</u>	<u>DESCRIPTION</u>
1	A8004A	Actuating frame
2	A8005	Pin, 1 1/2" x 2-3/4" w/ tab head
3		Bolt, 5/8" x 1-1/2" NF w/ lockwasher & nut
4	A8001	Pin, 2" x 7-1/8" w/ tab head
5		Capscrew, 5/8" x 1-1/4" NC w/ lockwasher
6	A8007A	Pin, 1-1/4" x 7-3/8" w/ tab head
7		Capscrew, 5/8" x 1-1/4" NC w/ lockwasher
8	A6015	Actuating link, upper half
9	A6016	Actuating link, lower half
10	A6018	Compression spring, 1" ID x 2" OD x 10" long
11		Nut, 1" NF
12	A6019	Shoulder pin, 1-1/4" to 1-5/8" w/ zerk in thread end
13	A8008	Pin, 1-1/2" x 3-5/8" w/ square head Cotter pin, 1/4" x 2"
14		Washer, 1-1/2"
15	A8009A	Actuating arm

BUCKET & APRON ASSEMBLY

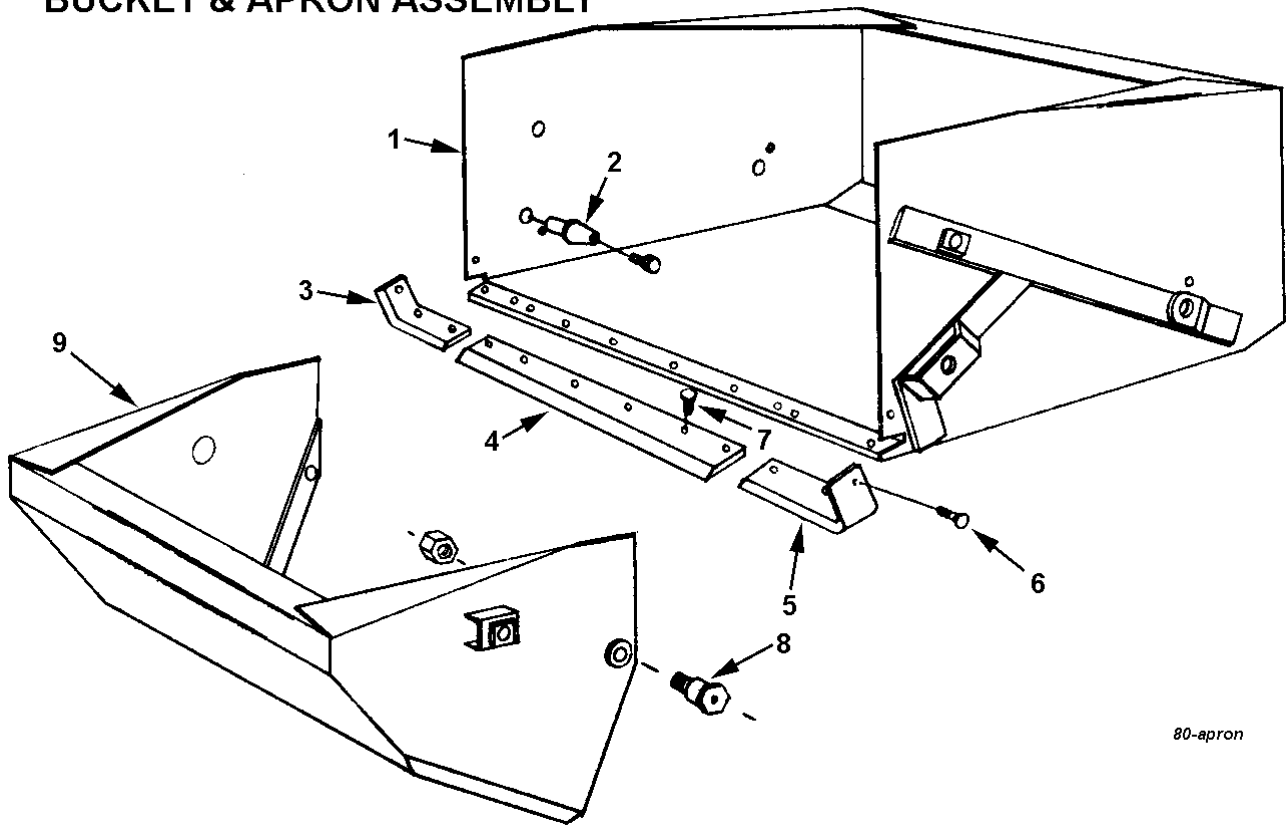

80-apron

<u>KEY NO.</u>	<u>PART NO.</u>	<u>DESCRIPTION</u>
1	A8010	Bucket
2	A8005	Pin, 1-1/2" x 2-3/4" w/ tab head
		Bolt, 5/8" x 1-1/2" NF w/ lock nut
3	A8029A	Right cutting edge, 3/4" x 6"
4	A8030	Center cutting edge, 3/4" x 8" x 54"
5	A8031A	Left cutting edge, 3/4" x 6"
6		Plow bolt, 1/2" x 1-3/4" w/ nut (6 req'd)
7		Plow bolt, 5/8" x 2" w/ nut (6 req'd)
8	A6010	Shoulder pin, 1-1/4" to 1-5/8" w/ zerk in head
9	A8011	Apron

WHEEL, HUB & SPINDLE ASSEMBLY

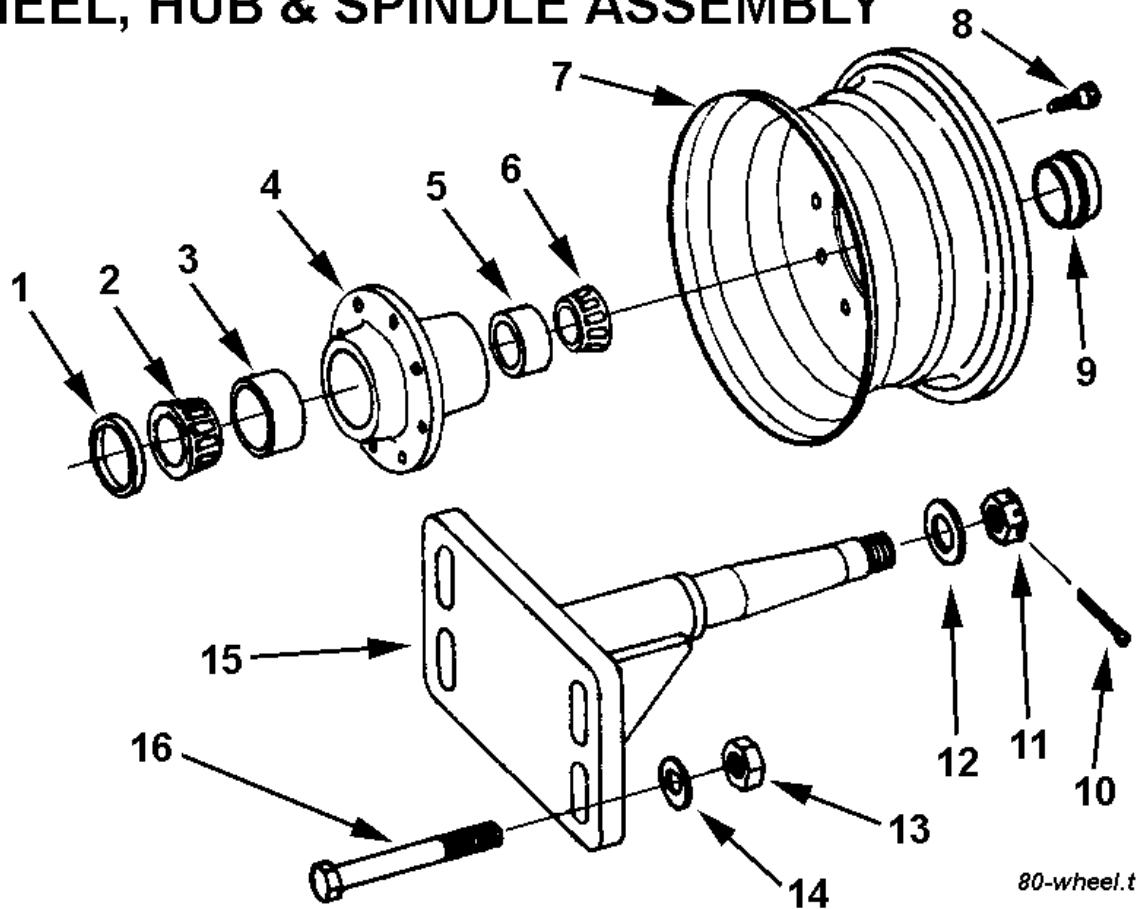

80-wheel.tif

s/n 12592 & up

KEY NO.	PART NO.	DESCRIPTION
1	A8020	Grease seal
2	A8021	Bearing cone, inner
3	A8022	Bearing cup, inner
4	A8023	Hub (casting # Q848)
5	A8024	Bearing cup, outer
6	A8025	Bearing cone, outer
7	A4521A	Wheel, 20" x 7" drop center
	A6022	Wheel, 16" x 11" drop center (optional)
	A8013	Wheel, 16" lock rim (optional)
8	A4519	Wheel bolt, 9/16" NF
9	A8026	Hub cap
10		Cotter pin
11		Spindle nut, slotted 1-1/4" NF
12	A8027	Spindle washer
13		Nut, 1" NC
14		Flatwasher, 1"
15	A8028	Spindle weldment
16		Bolt, 1" NC x 6-1/2" lg

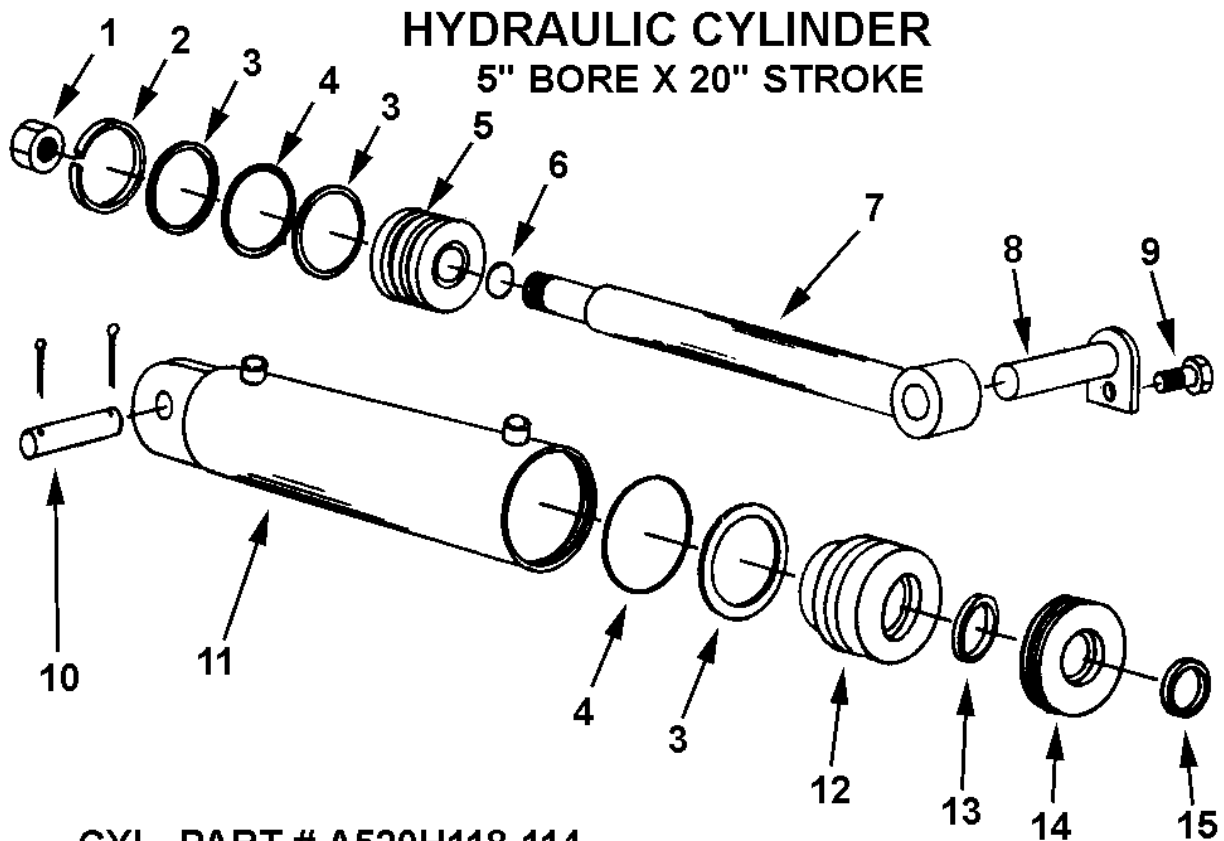

80-hyd-cyl

KEY NO.	PART NO.	DESCRIPTION
1	A400H17	Nut, 1-1/4" NF, lock type
2	A400H04	Cast ring, 5" OD
3	A400H05	Backup washer, 5" OD x 1/4"
4	A400H06	O-ring, 5" OD x 1/4"
5	A80H01	Piston, 5" OD
6	A60H52	O-ring, 1-1/4" ID x 1/16"
7	A80H08A	Shaft, 2" dia.
8	A8007A	Pin, 1-1/4" x 7-1/2" w/ tab head
9		Capscrew, 5/8" x 1-1/4" w/ lockwasher
10	A45003	Pin, 1-1/8" x 3-1/4"
		Cotter pin, 3/16" x 1-1/2"
11	A80H02	Barrel assembly, 5" ID
*12	A80H03	Head gland, 5" OD
13	A80H04	Seal, 2" ID
*14	A80H05	Head cap
15	A80H06	Wiper seal, 2" ID
	A80H07	Packing kit containing:
		1 - A400H04 1 - A60H52 3 - A400H05
		1 - A80H04 2 - A400H06 1 - A80H06
*16	A80H05A	One piece Gland and Cap

HOW TO OPERATE THE W7B-20DC RIM

Note: This rim has been developed for 20" used truck tires up to and including 9.00-20 ten ply. However, many users have found it possible to mount 10.00-20 twelve ply tires. The following procedures should be followed:

Tools and Materials Required:

One Set Firestone Truck Tire Tools (48-A-200)
 One Pair Vise-Grip Pliers
 Lubricant (Avoid use of compound that contains water . . . or a solvent injurious to rubber — see your rim distributor)

MOUNTING:



1. Remove flap inasmuch as it is not required on the drop center rim mounting and it prevents mounting the tire. Check to see tube is in casing and inflated sufficiently to prevent sag below tire beads.



2. Place rim on floor with valve hole side up. Place tire over rim with valve stem pointing upwards. Force lower bead into well of rim as far as possible.



3. Lubricate last section of lower bead to facilitate mounting.



4. Using straight end of tool (with stop resting on rim flange) take small bites to work remaining section of lower bead onto rim.



5. Stand tire up with valve and valve hole at top of rim. Insert valve into valve hole.



6. To get top bead in place stand on tire and force bead down as far as possible and clamp vice grip pliers on the flange. (snub side toward tire). Using spoon end of tire iron with lug side towards rim, work progressively around bead using small bites until bead slips over flange onto rim base. In order to mount last 6" of bead it usually is necessary to insert second tire iron and lubricate the last bead portion.

DEMOUNTING:



1. Remove valve core to deflate and loosen tire from bead seat of rim on both sides. Lubricate upper bead of tire thoroughly. With stops toward rim, insert spoon ends of both tools about 10 inches apart. While standing on tire to hold bead in well, pull one tool back toward center of rim.



2. Hold first tool in position with one foot and pull second tool toward center of rim. Progressively work top bead off rim, taking additional bites if necessary.



3. Stand tire and tube in vertical position with valve at top of assembly and remove valve from valve hole. Then place valve at bottom of assembly and pull out upper portion of tube so it will not interfere with demounting the second bead. Lubricate second bead. At top of assembly insert straight end of tool between bead and back flange of rim at about a 45° angle. Turn tool so it is perpendicular to rim. Pry second bead off.

ELECTRIC WHEEL COMPANY-QUINCY, ILL.

Division of the Firestone Tire & Rubber Company